

motralec

4 rue Lavoisier . ZA Lavoisier . 95223 HERBLAY CEDEX
Tel. : 01.39.97.65.10 / Fax. : 01.39.97.68.48
Demande de prix / e-mail : service-commercial@motralec.com
www.motralec.com



POLYURETHANE FOAM



Experience Shows • Innovation Flows

VIKING PUMP

A UNIT OF IDEX CORPORATION



OUR EXPERIENCE SHOWS IN...

Service to the Polyurethane Foam Industries

Viking Pump has been providing pumping solutions to the Polyurethane Industry since its inception. Common Viking® polyurethane applications include:

- Manufacture of base chemicals
- Equipment manufacturer
- Point of use foam production
- Blending, mixing and packaging

Polyurethane Manufacturing - Typical Layout Process Map

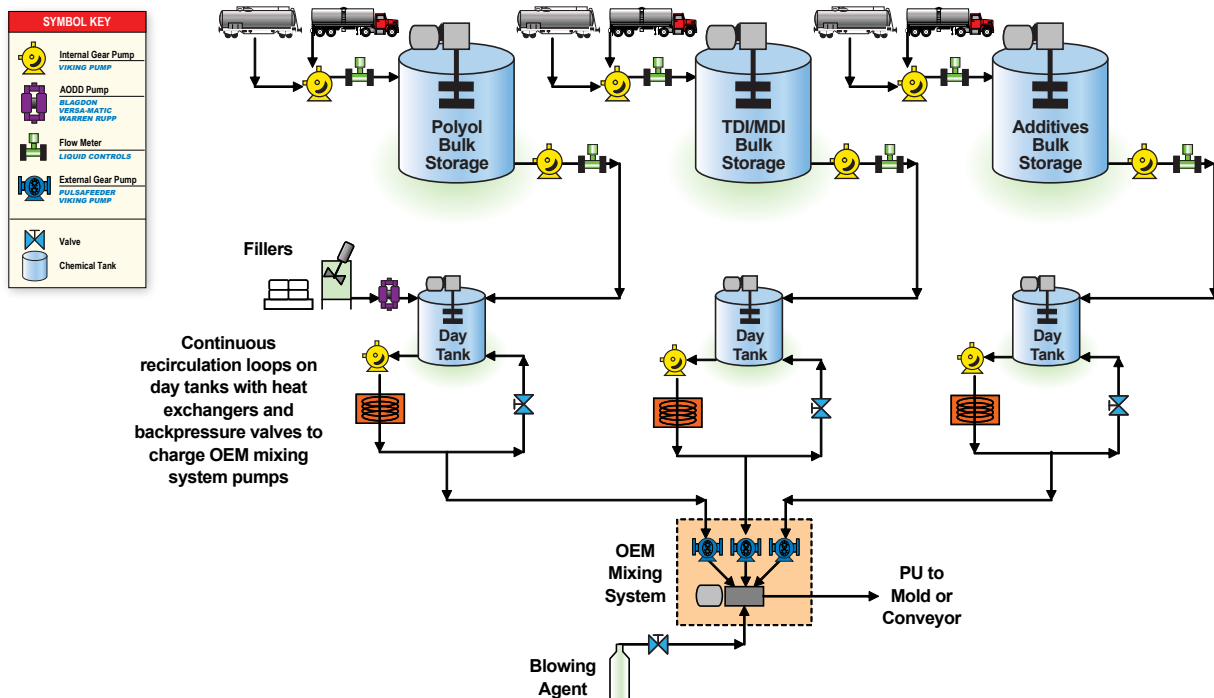



Problem-Solving Innovation

From the beginning, Viking® has worked with customers to develop new innovations in pump technology. Whether it is solving individual application problems or developing new industry leading ideas, Viking is always looking for ways of doing things better.

Shaft sealing is key in the polyurethanes industry and our history of innovation here is the same. Viking was one of the first pump companies to incorporate mechanical seals into its designs, replacing packing which is designed to leak. Working with mechanical seal suppliers, we developed pump designs to accommodate double and tandem seals to solve particularly difficult sealing problems. With the advent of cartridge mechanical seals, we were the first pump company to introduce a line of pumps designed specifically for them. The Universal Seal series provides not only

for easy installation and replacement of these seals, but also accommodates many other seal designs with little if any pump modification.

When rare earth magnets became feasible to produce on a large scale, Viking saw the need and developed the first commercially available Mag Drive internal gear pump. This design uses high strength magnets to transmit torque through a stainless steel canister. Liquid containment now is accomplished using only static seals for much better reliability.

As magnetic coupling designs have become more efficient, Viking has now developed a line of internal gear pumps that allow very easy upgrade to Mag Drive from existing designs. New models drop right in, meaning there are no expensive piping or drive modifications required.



Cartridge Lip Seal



Single Mechanical Seal

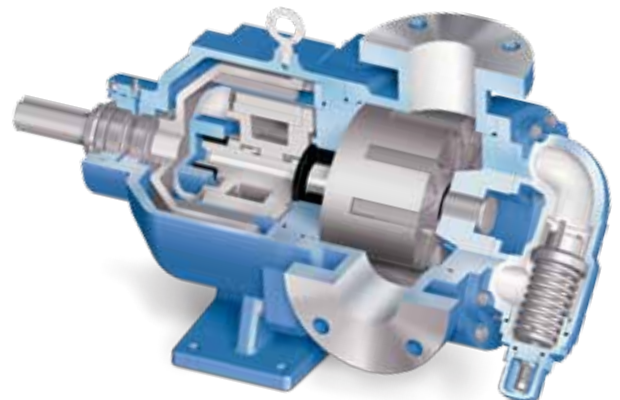



Unloading Pump



TDI Delivery Pump

OUR EXPERIENCE SHOWS IN...

Manufacture of Base Chemicals

This is where foam production begins, and if it doesn't move smoothly here, there may be problems down the line. Viking Pump delivers on the challenges facing today's polyurethane base chemical manufacturers.

Viking® manufactures the largest internal gear pump in the industry today, with flow capabilities up to 360 M³/Hr (1600 GPM). In addition to packed and mechanical seal models, Viking offers industry leading sealless Mag Drive pump solutions for difficult to seal liquids such as isocyanates (MDI, TDI) or hazardous liquids like catalysts and additives.

Viking pumps swiftly and efficiently convey even thick polyols through processing operations to storage and transport, helping to ensure on-time delivery and productivity is on-target. Along the way, our pumps handle long pipeline head losses, thanks to discharge pressure capabilities up to 14 BAR (200 PSI).

Equipment Manufacturer

Viking pumps deliver repeatable accuracy, essential for the metering and mixing of the base chemicals.

Viking offers over 20 sizes of Mag Drive pumps under 2.2 M³/Hr (10 GPM) allowing OEMs to size the pump to the application versus the application to the pump. These pumps are available in close-coupled motor mounted configurations to help OEMs keep their equipment simple, compact and lightweight.



Acoustical Foam



Spray Foam Application

Point of Use Foam Production

Viking® pumps used for foam production can be found in virtually every industry. These include but are not limited to the manufacture of:

- Appliances
- Automobile components
- Sporting goods
- Furniture
- Thermal and sound insulation
- Block and slab foam stock
- Spray on truck bed liners
- Shoes
- Carpet padding

With nearly 100 years of application experience and countless successful installations, end-users have come to rely heavily on Viking’s expertise to solve their liquid handling problems. In addition, Viking’s industry leading warranty and a vast stocking Distributor Network offers “best in class” support in over 68 countries. Whether it’s repairs, replacement parts or complete pumps, your local authorized Viking Pump Distributor provides fast and knowledgeable service.

Universal Mag Drive Provides Across the Board Savings for Customer.

When a major chemical producer required MDI pumps for their China facility, they selected Viking Pump. These QS, stainless steel Mag Drive internal gear pumps were built to order for transferring MDI at 100 M³/Hr (440 GPM)

and 12 BAR (170 PSI). Viking Pump was considered because of our wide range of Mag Drive pumps. Viking pumps were chosen because of our polyurethane pumping experience and our world class global support.



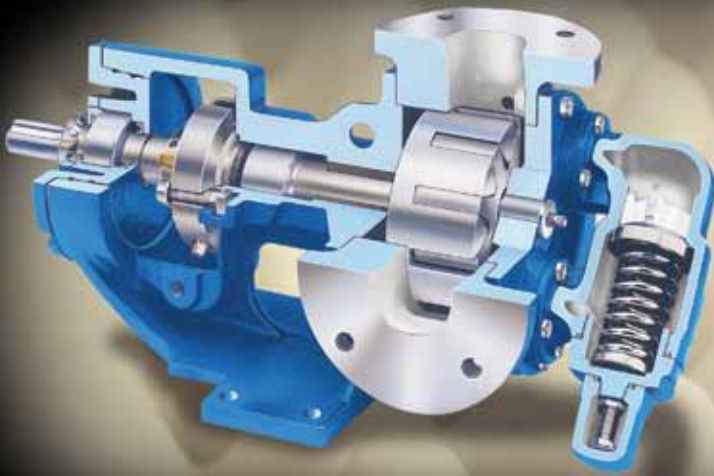

Universal Seal Internal Gear Pump

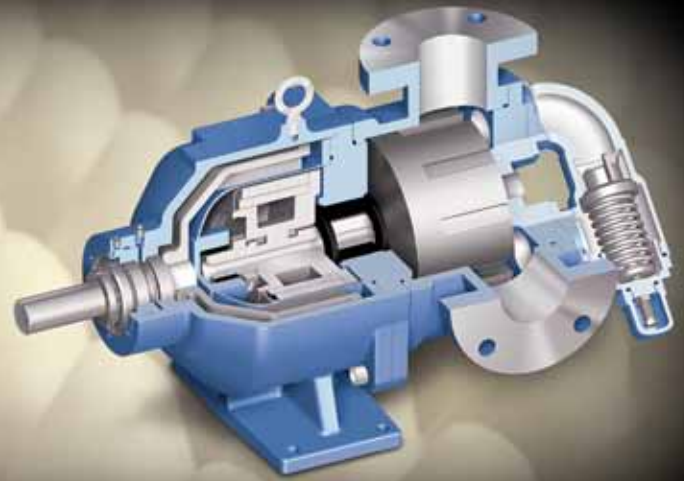

Universal Mag Drive Internal Gear Pump

OUR EXPERIENCE SHOWS IN...

Viking Pump Benefits

Low shear - Viking® pumps operated at low speeds minimize liquid shear and protect the product integrity.

Ability to handle thin or thick liquids - the same Viking pump can handle solvents less than 1 cSt or polymers more than 500,000 cSt.

Shaft sealing - Viking offers a broad array of shaft sealing solutions, including packing, lip seals, component mechanical seals, and off-the-shelf cartridge seals from virtually every major manufacturer. Viking also offers sealless, Mag Drive pumps for the highest level of liquid containment available.

Customizability - Viking pumps can be easily customized with thousands of options for materials, porting and sealing, to ensure that each pump is optimized for the material and the application.

Viking Pumps for Polyurethane Applications

Universal Seal Internal Gear Pumps

- Applications: Polyol and some isocyanates, and hardened material options for handling filled, abrasive polymers
- Cast iron, ductile iron, steel and stainless steel construction
- 16 Displacements available
- Capacities to 360 M³/Hr (1600 GPM)
- Pressures to 14 BAR (200 PSI)
- Temperatures to 420°C (700°F)
- Industry leading 3-year warranty

Customer Benefits

- Pumps accommodate virtually all sealing types and manufacturers
- Industry leading selection of application specific material options to maximize pump life
- Design adaptability for an unequalled range of viscosities and temperatures
- Easy clearance adjustment to maintain high efficiency
- Simple design with only two moving parts
- Back pull-out seals
- No special tools required for service

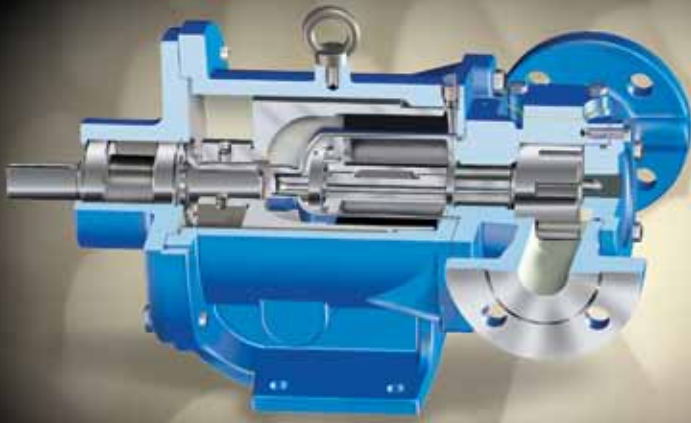

855 Series Mag Drive Internal Gear Pump

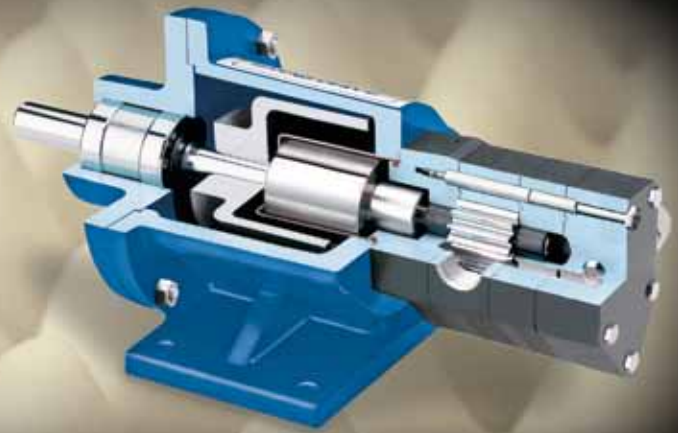

SG Series Mag Drive External Gear Pump

Mag Drive Internal Gear

- Applications: Isocyanate, Polyol, and Additives, Transfer, Mixing and Metering
- Cast iron, steel and stainless steel construction
- 16 Displacements available
- Capacities to 114 M³/Hr (500 GPM)
- Pressures to 14 BAR (200 PSI)
- Temperatures to 260°C (500°F)
- Industry leading 3-year warranty on Universal Mag Drive series

Customer Benefits

- Universal Mag Drive series is dimensionally interchangeable with its Universal Seal series counterparts
- Proven internal gear design provides superior flexibility to the most challenging applications where shaft sealing is crucial
- Wide flow range to better match application requirements
- Pump design offers ANSI or DIN flanges, and IEC or NEMA motor mounts conform to international standards for enhanced application flexibility
- Short-term run-dry capabilities provide for line clearing or empty tank situations without damaging pump
- Space-saving mounting configurations available

Spur Gear (SG) Series External Gear

- Applications: Isocyanate, Polyol, and Additives, RIM equipment, Mixing and Metering
- Cast iron, ductile iron, and composite construction
- Sealing options: single and double lip seals, mechanical seals, sealless Mag Drive models
- 23 Displacements available
- Capacities to 7.3 M³/Hr (32 GPM)
- Pressures to 170 BAR (2500 PSI)
- Temperatures to 232 °C (450 °F)

Customer Benefits

- Evenly incremented displacements provide a pump within 20% of your capacity needs
- Precision machined components afford precise metering and flow control for increased process accuracy
- Variety of sealing options including Mag Drive (sealless) to cost-effectively meet your application needs
- Double pump configurations offer two flow rates operating from single power source, reducing equipment costs
- Close-coupled motor mount, foot bracket, and base-mounting options available to match your space or motor requirements

Innovation and Experience

Viking Pump has been a pump industry leader and innovator since its founding in 1911. We continue to build on our ever growing experience delivering innovative new pumping solutions, including custom designs, to many thousands of customers who use millions of Viking® pumps in some of the world's toughest applications.

Broad Performance Range

Capacity:

0.5 to 360 M³/Hr (0.1 to 1,600 GPM)

Pressure:

0 to 172 Bar (0 to 2,500 PSI)

Temperature:

-40°C to 370°C (-40°F to 700°F)

Viscosity:

0.5 to 1,000,000 cSt (28 to 4,500,000 SSU)

Ultimate in Sealing Solutions

Viking's offering of packing, component mechanical seals, cartridge seals, and sealless Mag Drive technology provides the best choices for sealing flexibility needed to provide your application a customized sealing solution every time - saving you money, time, and unplanned downtime.

Material Options Matched to Application

Viking's dedicated iron and alloys foundries provide pump construction materials from cast iron to Alloy C. Application-specific materials of construction extend pump life significantly, while reducing maintenance and unplanned downtime, which enables increased production and a better bottom line.

Liquid Integrity Protection

Viking has developed multiple positive displacement pump principles to protect shear-sensitive liquids, and low-shear options to prevent damage to fibers, polymers, and solids. Full-jacketing options provide precise temperature control throughout the pump. The Viking Mag Drive® and other seal options prevent fluid contact with air, assuring liquid integrity.

Local Applications and Engineering Support

Over 245 Authorized Viking Pump Distributors in 68 countries provide local application support and service, backed by Viking Application Engineers and Viking Region Managers strategically located around the world.

Quality Manufacturing

Viking uses ISO9001-2000, Six-Sigma, and Lean/Kaizen in its worldwide manufacturing and assembly processes to remove waste, reduce development costs, and deliver superior products on schedule. Dedicated Viking foundries and manufacturing facilities utilize state-of-the-art CNC equipment to assure unmatched quality is built into every pump.

Custom Designed Solutions

Viking has provided custom designed pumps to end-users and OEMs since its first pump in 1911, when Viking invented the gear-within-a-gear pumping principle to remove water from a rock quarry. Today, enabled by Viking's engineering staff, extensive applications experience, and in-house foundries, more than 20% of Viking's sales are new Viking designs, or pumps designs derived from more than 1,000 Viking catalog pumps with more than 40,000 active configurations. So, whether you are an end-user or an OEM, Viking can provide custom designed pumping solutions to meet your specific needs.