

E3 3" Clamped Metallic Pumps Specifications and Performance

SPECIFICATIONS

E3

FLOW RATE (Adjustable) 0-260 gpm (984 lpm)

PORT SIZE

Inlet and Outlet..... 3.0" NPT (BSP)

AIR INLET 0.5" NPT

AIR EXHAUST 1.0" NPT

SUCTION LIFT 20' Dry/25' Wet (6.10m/7.62m)

Teflon®..... 10' Dry/20' Wet (3.05m/6.10m)

MAX. PARTICLE SIZE (Dia.) 0.375"(9.52mm)

SHIPPING WEIGHTS

Aluminum 115 lbs (52.16 kg)

Cast Iron, Stainless..... 210 lbs (95.25 kg)

Hastelloy C..... 220 lbs (99.79 kg)



PERFORMANCE Determined by actual flow meter tests.

E3

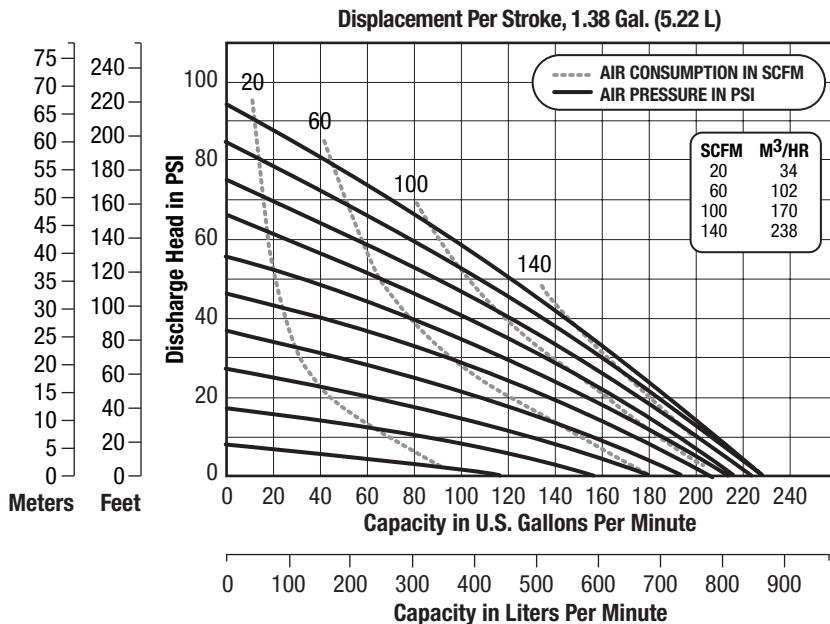

NOTE: For E3 pumps fitted with Teflon® diaphragms, reduce water discharge figures by 20%. Suction lift is reduced to 10' (3.05m) dry and 20' (6.10m) wet.

CAUTION: Do not exceed 125 psig (8.5 bars) air supply or liquid pressure.
Screen Mount Available For Aluminum Model.

DIMENSIONS Consult factory for certified drawings.

E3

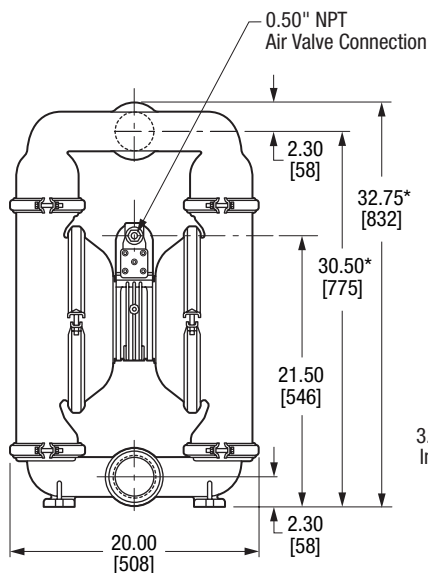

* Measurement is for Cast Iron pumps. Other materials of construction may be slightly smaller.

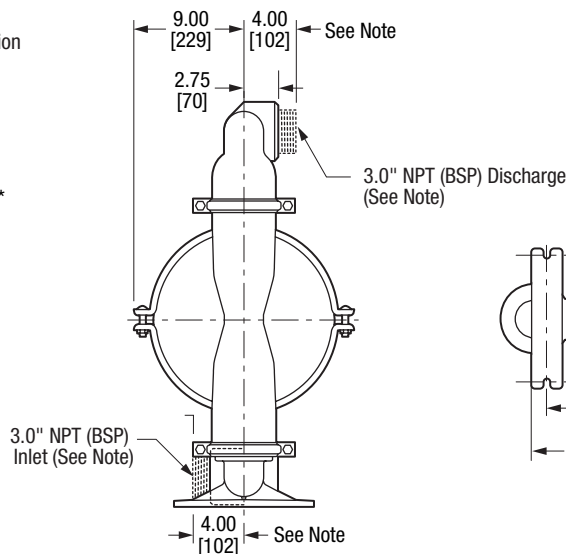

NOTE: Cast-in-Place Nipple, Aluminum Pump Only. Female threaded on others.

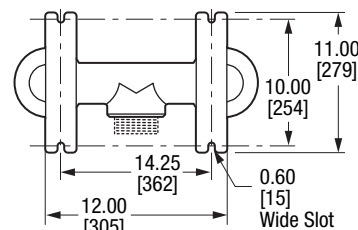

inches [mm]