

TRAVAINI PUMPS USA

TRSA 200

Single Stage Medium Vacuum Pumps

PERFORMANCE DATA	: From 150 Torr	CAPACITY:	1000 - 2200 cfm
FEATURES	: Single-stage rotating pump with externally located bearings grease lubricated.		
SHAFT SEALING	: Mechanical seal - Double mechanical seal – Packing seal.		
OPTIONS	: Bareshaft pump - Coupled to electric motor on baseplate		



TECHNICAL DATA							
PUMP TYPE		TRSA 200-1950		TRSA 200-2500		TRSA 200-3100	
Speed	RPM	730	880	730	880	730	880
Motor - installed power	HP	75	125	100	150	125	200
Average service liquid flow	GPM	59	59	71	71	78	78
Noise level at 189 Torr	dB(A)	84	85	84	85	85	85
Minimum suction pressure	Torr	150	150	150	150	150	150

Pumps are provided with threaded connections for service liquid, pump draining, grease and anticavitation valve and companion flanges. Pumps are also provided, by request, with auxiliary threaded connections, flanged air-liquid separator tank, non return valve, vacuum relief valve, flow valve to control the flow of the liquid supply, vacuum gauges, pressure gauges and compound gauges. We can also provide information on our water sealed and oil sealed systems. For more detailed information please contact our Sales Office.

Example for Model Designation		Standard Materials of Construction					
<u>T R S A 200 - 3100 / C / GH</u>		Part No.	Description	GH	F	RA	A3
T	Travaini Pump USA construction	106	Suction casing	Cast Iron			
R	Liquid Ring Pump	107	Discharge casing				
S	Single stage pump for medium vacuum	137	Port Plate				
A	Design number	110	Impeller housing				
200	Flange size (mm)	210	Shaft	Stainless Steel AISI 420		Stainless Steel AISI 316	
3100	Nominal capacity (m ³ /h)	147	Manifold	Steel			
C	Shaft sealing C = Mechanical seal C2 = Double mechanical seal B = Packing seal	357	Bearing housing mech. seal	Cast Iron			
GH	Materials of construction GH-F-RA-A3 = See table	230	Impeller	Bronze	Ductile Iron	Stainless Steel AISI 316	

Special Materials Available Upon Request

Indicative table: for further information please consult our Sales Office

DATA BASED ON :
 DRY AIR AT 68 °F - 20 °C
 SATURATED AIR AT 68 °F - 20 °C
 SERVICE LIQUID WATER
 SERVICE LIQUID TEMPERATURE 59 °F - 15 °C
 DISCHARGE PRESSURE 1013 mbar

S.S. PUMPS
 CAPACITY : -10%

PERFORMANCE DATA
 LIQUID RING VACUUM PUMP
 PUMP MODEL
TRSA 200-1950

Tol.: 10%

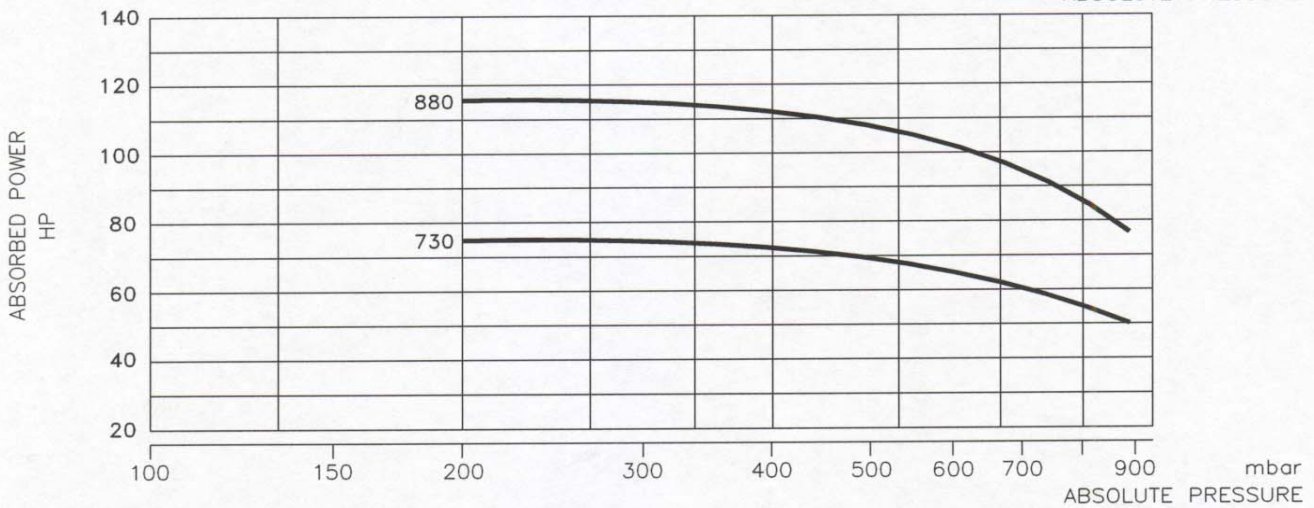
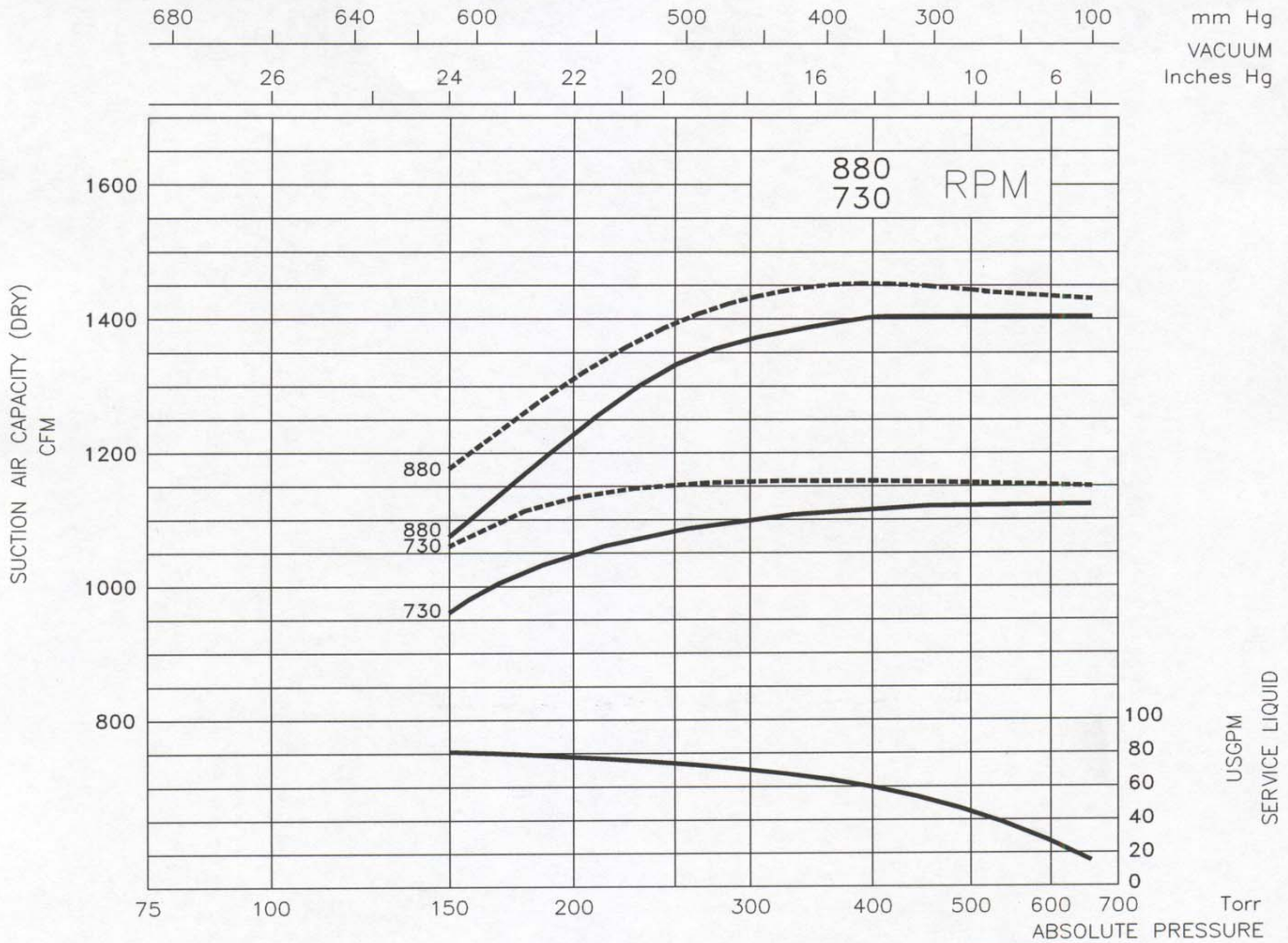

DATE: APRIL 97

PAGE NO:

DATA BASED ON :
 DRY AIR AT 68 °F - 20 °C
 SATURATED AIR AT 68 °F - 20 °C
 SERVICE LIQUID WATER
 SERVICE LIQUID TEMPERATURE 59 °F - 15 °C
 DISCHARGE PRESSURE 1013 mbar

S.S. PUMPS
 CAPACITY : -10%

Tol.: 10%

PERFORMANCE DATA
 LIQUID RING VACUUM PUMP
 PUMP MODEL
TRSA 200-2500

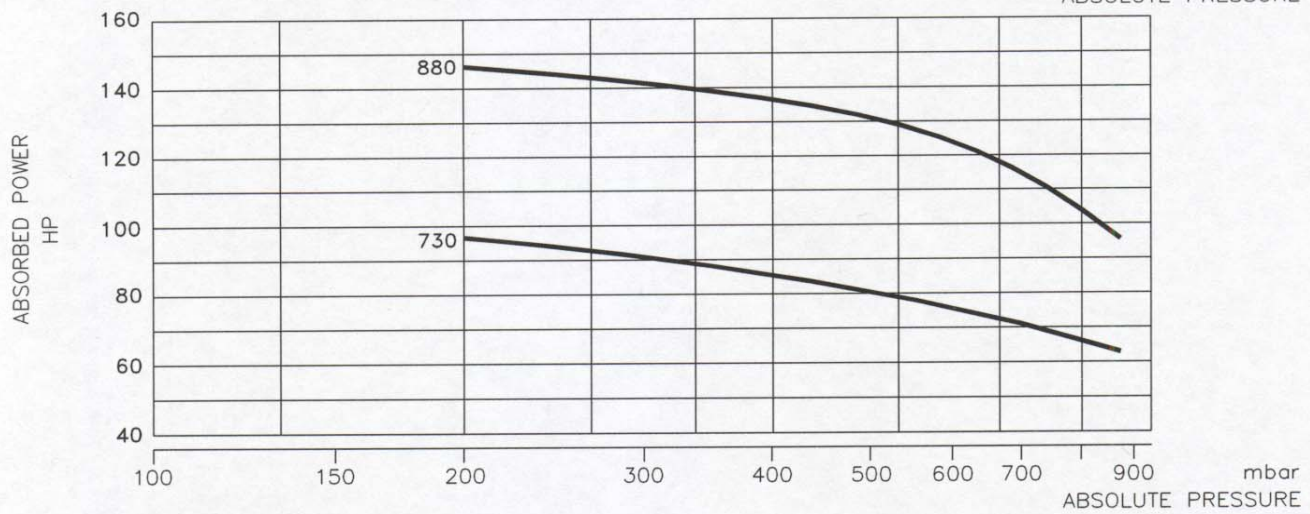
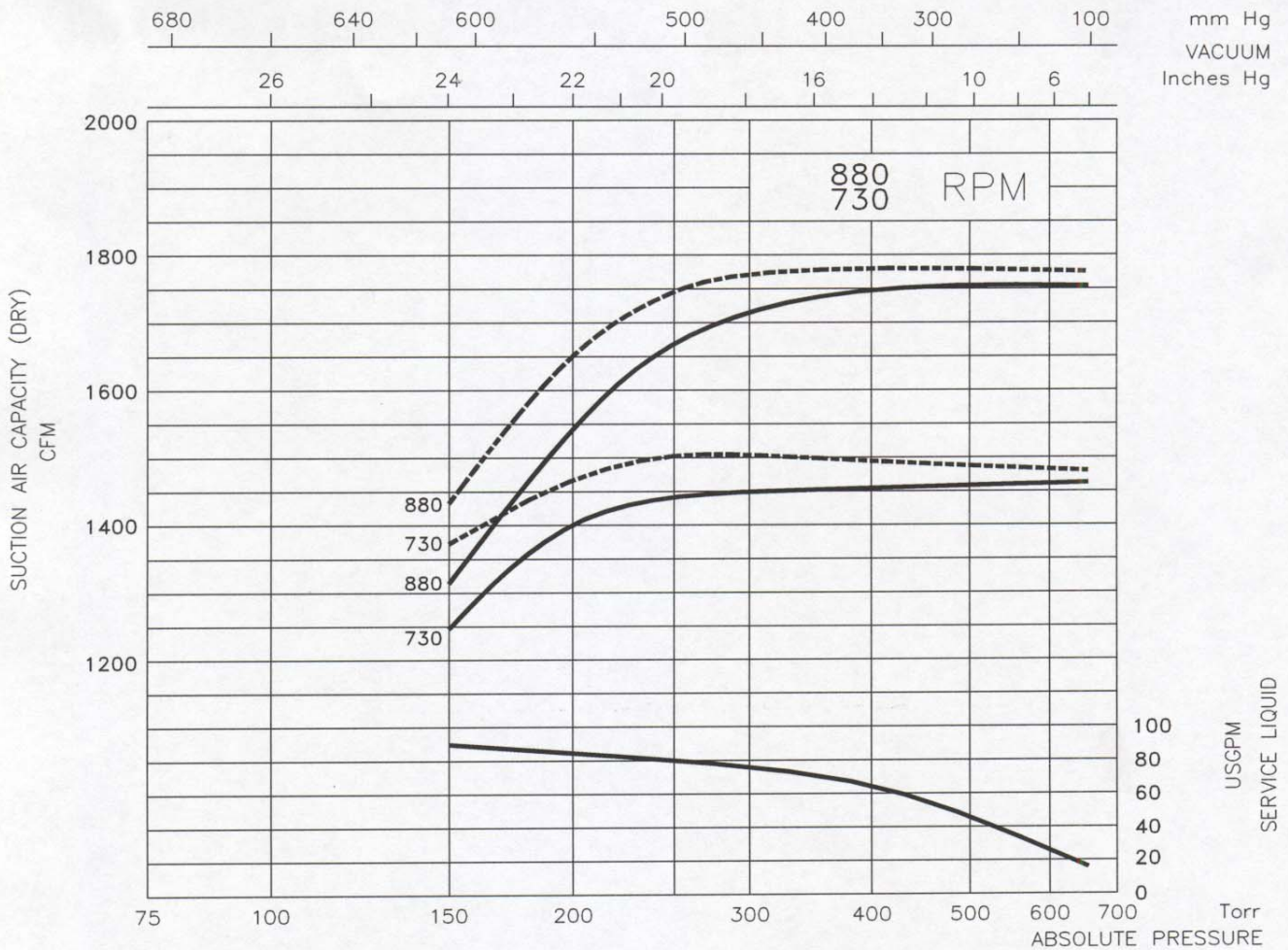

DATE: APRIL 97

PAGE NO:

DATA BASED ON :
 DRY AIR AT 68 °F - 20 °C
 SATURATED AIR AT 68 °F - 20 °C
 SERVICE LIQUID WATER
 SERVICE LIQUID TEMPERATURE 59 °F - 15 °C
 DISCHARGE PRESSURE 1013 mbar

S.S. PUMPS
 CAPACITY : -10%

Tol.: 10%

PERFORMANCE DATA
 LIQUID RING VACUUM PUMP
 PUMP MODEL
TRSA 200-3100

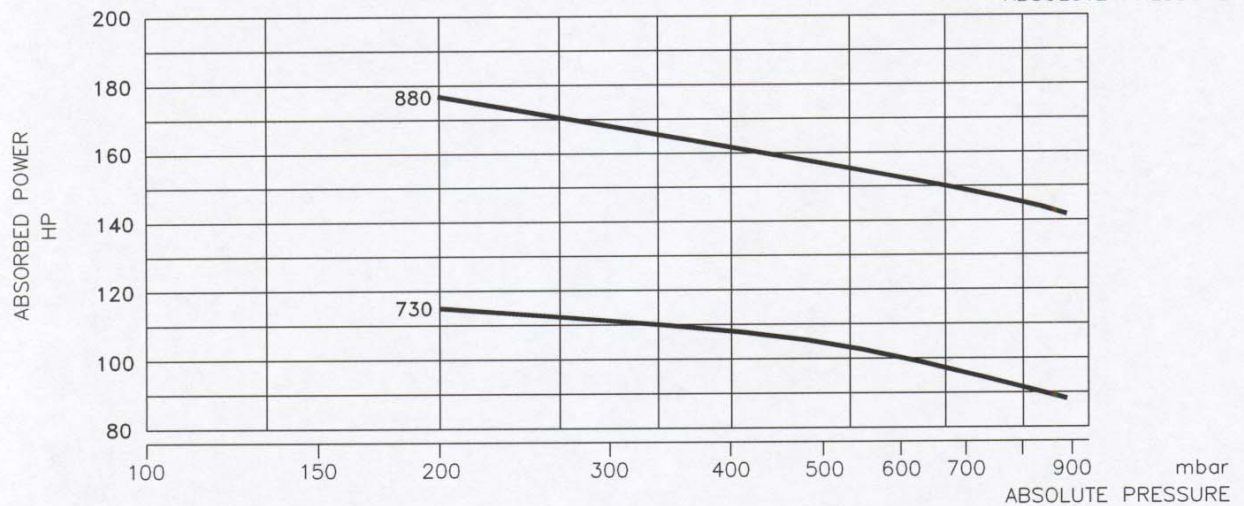
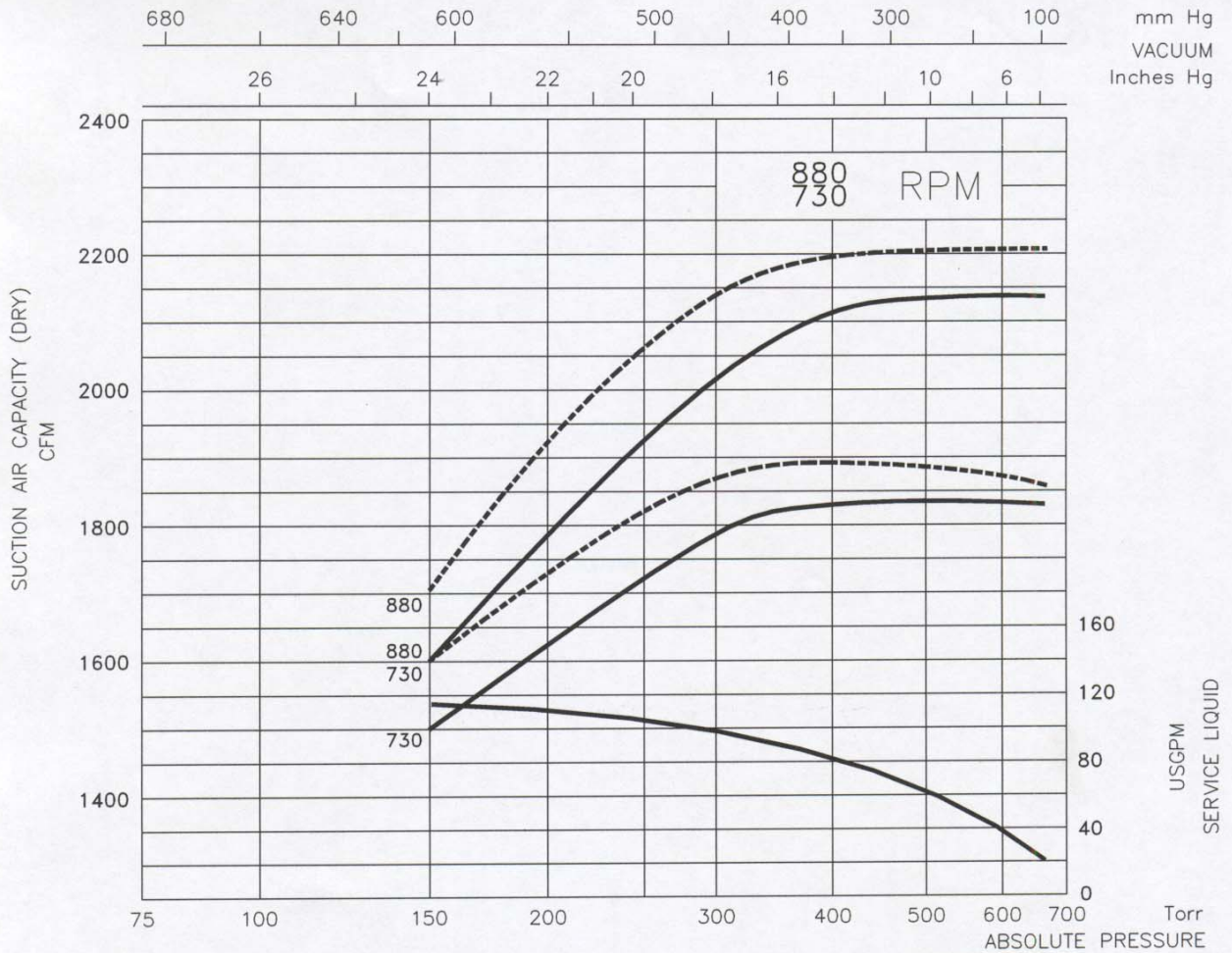

DATE: APRIL 97

PAGE NO:

TRSA 200/C

Bareshaft Construction with Mechanical Seal

Pump Type	Pump									Weight lbs.
	B	E	G	G1	K	L	N	Y	J	
TRSA 200-1950/C	710	830	872	402	1410	787	623	262	463	2475
TRSA 200-2500/C	810	930			1510	837	673		474	2695
TRSA 200-3100/C	910	1030			1610	887	723		476	2915

Y = Dimension valid for pumps in Cat Iron (GH) construction.

J = Dimension valid for pumps in S.S. AISI 316 (A3) construction.

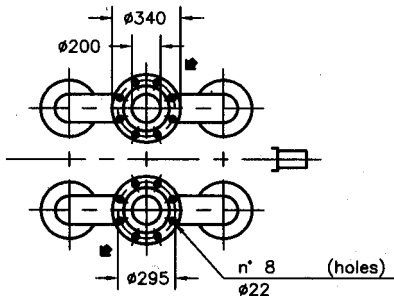
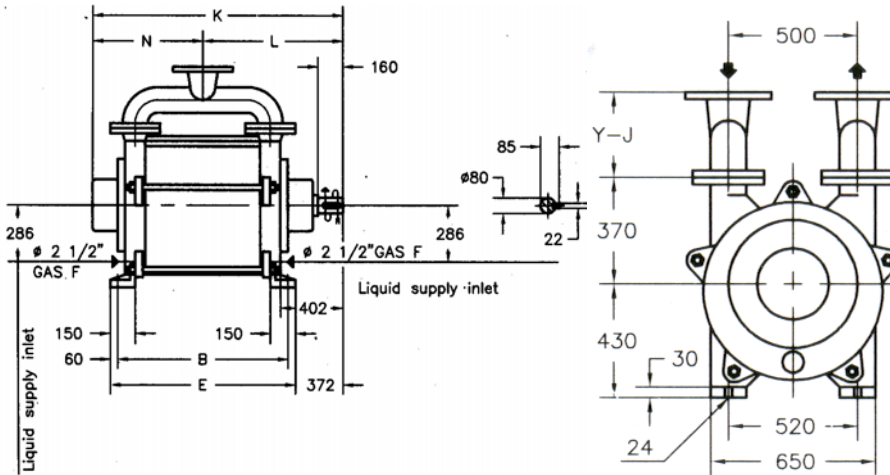

Note: Dimensions in mm.
(mm to in = /25.4)

Base-Mounted Construction (Baseplate-Coupling) with Mechanical Seal

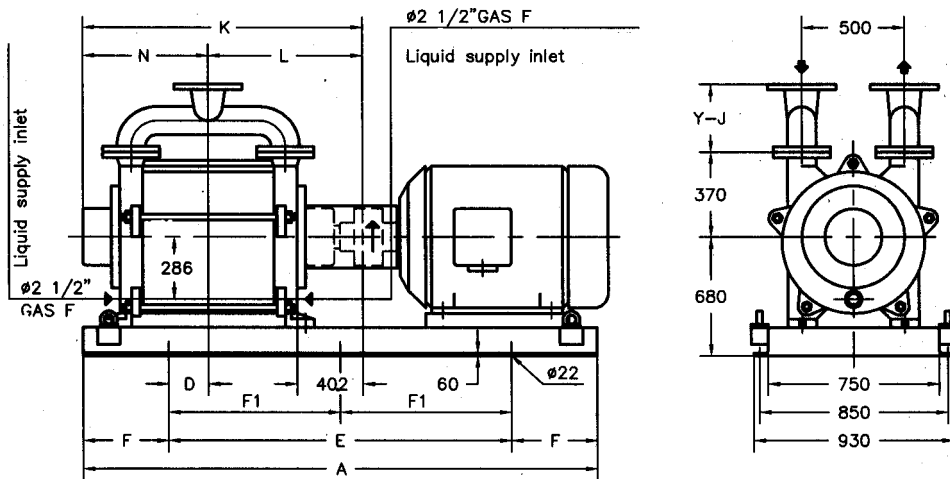

Pump Type	8 Poles Motor HP	Base-plate	Pump									Weight ¹ lbs.			
			A	D	E	F	F1	K	L	N	Y		J		
TRSA 200-1950/C	100	60F	2400	350	1800	300	900	1410	787	623	262	463	3520		
	125			340											
TRSA 200-2550/C	100			190										474	3740
	150			200											
TRSA 200-3100/C	150	61F	2800	230	1900	450	950	1610	887	723	262	476	3960		
	215			230										4268	

¹ Weight without motor

Dimensions for reference only
Please consult factory for
The weights refer to GH
construction

TRSA 200 – 1950/C, 2500/C, 3100/C

Typical Cross Section with Mechanical Seal

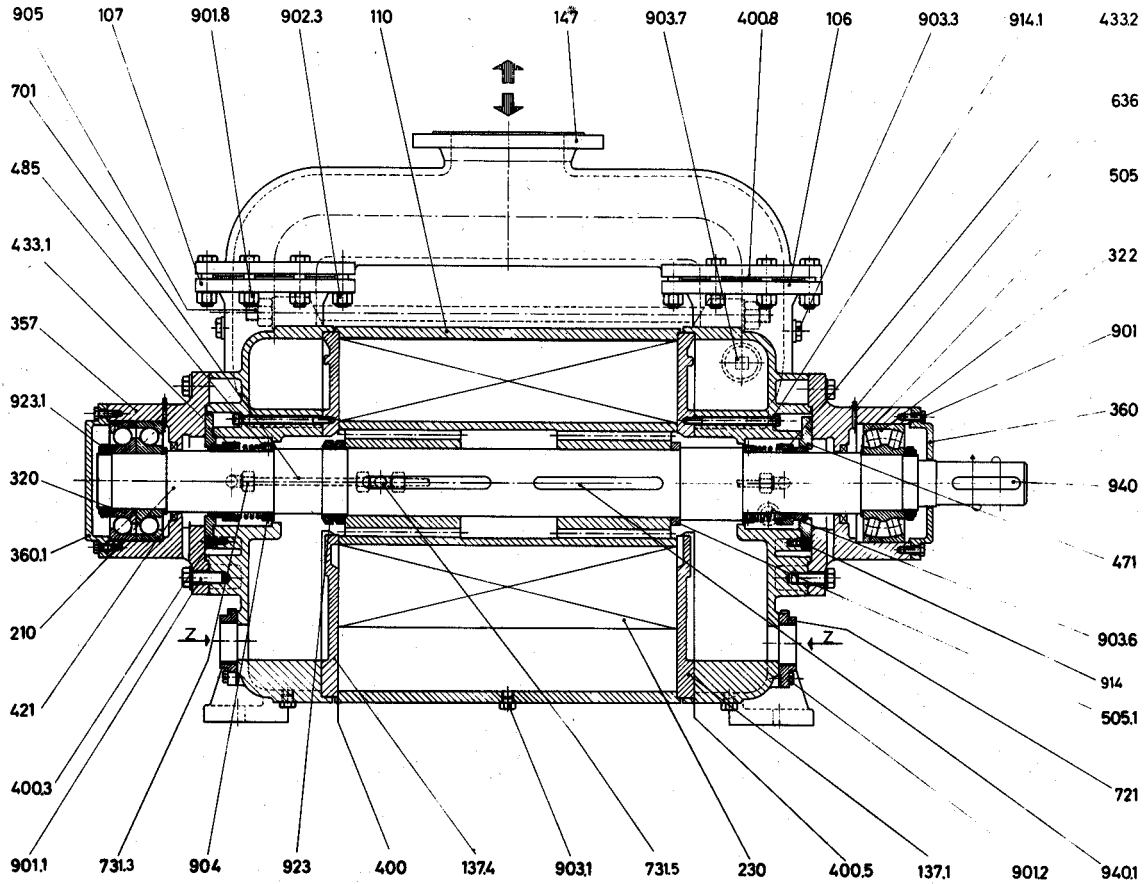

COMPONENTS

VDMA No	DESIGNATION
106	Suction casing
107	Discharge casing
110	Impeller casing
137.1	Side element
137.4	Side element
147	Manifold
• 210	Shaft
• 230	Impeller
• 320	Ball bearing
• 322	Ball bearing
357	Bearing and mech. seal house.
360	Bearing cover
360.1	Bearing cover
• 400	Gasket
• 400.3	Gasket
• 400.5	Gasket

VDMA No	DESIGNATION
• 400.8	Gasket
• 421	Radial seal ring
• 433.1	Mechanical seal c.c.w
• 433.2	Mechanical seal c.w.
471	Mechanical seal cover
485	Mech. seal locking ring
• 505	Shoulder ring
• 505.1	Shoulder ring
636	Grease nipple
701	Pipe
721	Liquid supply flange
731.3	Fitting
731.5	Fitting
901	Screw
901.1	Screw
901.2	Screw

VDMA No	DESIGNATION
901.8	Bolt
902.3	Stud
903.1	Plug
903.3	Plug
903.6	Plug
903.7	Plug
904	Grub screw
905	Tie-bolt
914	Screw
914.1	Screw
923	Nut
923.1	Nut
940	Key
940.1	Key
Z	Liquid supply inlet

- Recommended spare parts

motralec

4 rue Lavoisier . ZA Lavoisier . 95223 HERBLAY CEDEX

Tel. : 01.39.97.65.10 / Fax. : 01.39.97.68.48

Demande de prix / e-mail : service-commercial@motralec.com

www.motralec.com