

► Immersion Range IMM 50/A

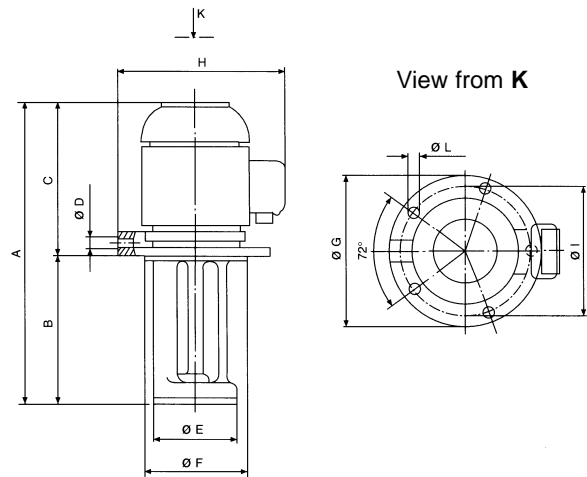

MECHANICAL FEATURES

Pump Body.....Valox
 Cover.....Valox
 Impeller.....Valox
 Shaft.....Steel

MOTOR CHARACTERISTICS

Protection.....IP55
 Insulation.....CL. F
 Voltage.....Eurovoltage 3PH & 1PH
 Frequency.....50Hz
 Terminal Box Gland.....PG9

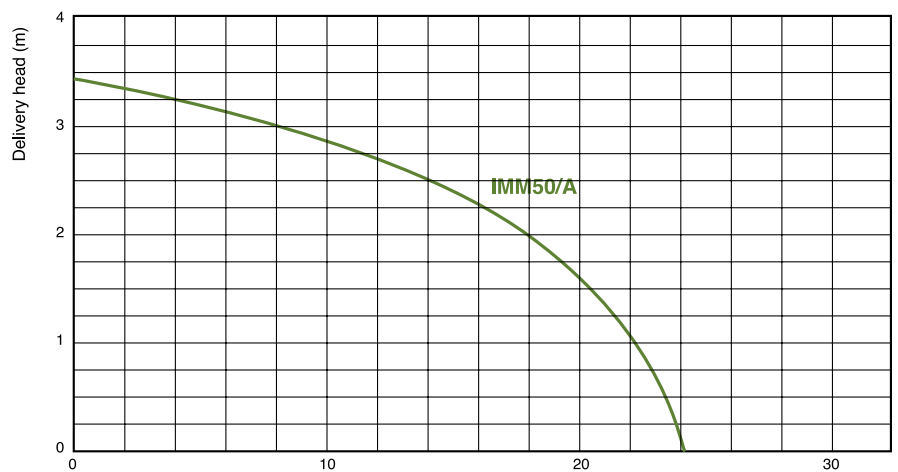

TYPE	KW Absorbed	AMPS 400 V	A mm	B mm	C mm	ØD mm	ØE mm	ØF BSP	ØG BSP	ØH mm	ØI mm	ØL mm	n° L	WEIGHT Kg
IMM 50/A	0.11	0.30	219	80	139	3/8"	78	90	130	140	114	7	2	1.90
	0.11	0.30	259	120	139	3/8"	78	90	130	140	114	7	2	1.93
	0.11	0.30	289	150	139	3/8"	78	90	130	140	114	7	2	1.95
	0.11	0.30	319	180	139	3/8"	78	90	130	140	114	7	2	1.98

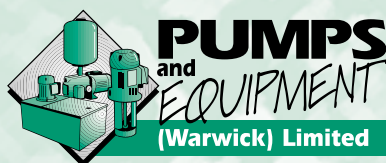

motralec

4 rue Lavoisier . ZA Lavoisier . 95223 HERBLAY CEDEX
 Tel. : 01.39.97.65.10 / Fax. : 01.39.97.68.48
 Demande de prix / e-mail : service-commercial@motralec.com
www.motralec.com