

► AU Range ELECTRIC PUMPS - SELF-PRIMING RANGE

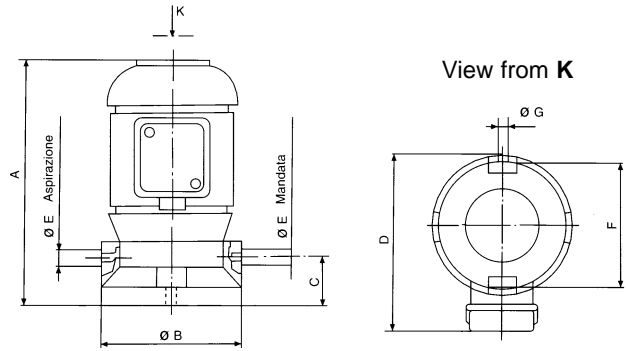

MECHANICAL FEATURES

Pump BodyAluminium
 ImpellerBronze

MOTOR CHARACTERISTICS

ProtectionIP55
 InsulationCL. F
 Voltage.....Eurovoltage 3PH & 1PH
 Frequency.....50Hz

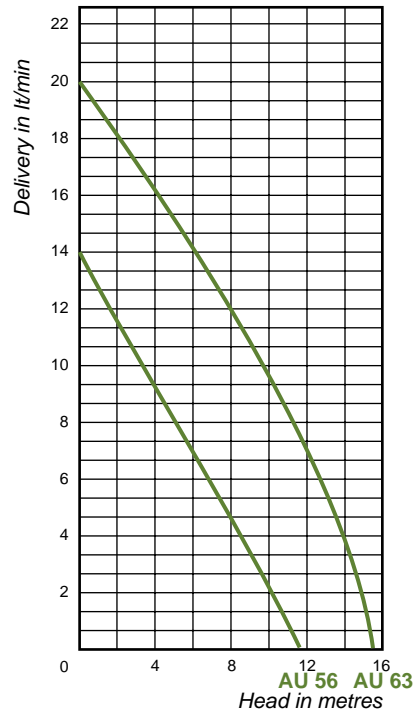

TYPE	KW Absorbed	HP	AMPS 400V	A mm	ØB mm	C mm	D mm	ØE mm	ØF mm	ØG mm	WEIGHT kg
AU 56	0.16	0.21	0.55	208	115	48	144	3/8" BSP	95	7	3.9
AU 63	0.30	0.40	0.58	215	130	48	144	1/2" BSP	95	7	4.9

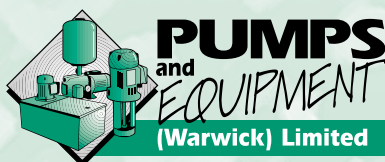

motralec

4 rue Lavoisier . ZA Lavoisier . 95223 HERBLAY CEDEX
 Tel. : 01.39.97.65.10 / Fax. : 01.39.97.68.48
 Demande de prix / e-mail : service-commercial@motralec.com
www.motralec.com