

# 2-4CR

## Multi-stage centrifugal pumps



### PERFORMANCE RANGE

- Flow rate up to **120 l/min** (7.2 m<sup>3</sup>/h)
- Head up to **50 m**

### APPLICATION LIMITS

- Manometric suction lift up to **7 m**
- Liquid temperature between **-10 °C** and **+40 °C**
- Ambient temperature up to **+40 °C**
- Max. working pressure **6 bar**
- Continuous service **S1**

### CONSTRUCTION AND SAFETY STANDARDS

EN 60335-1  
IEC 60335-1  
CEI 61-150

EN 60034-1  
IEC 60034-1  
CEI 2-3



### CERTIFICATIONS



### INSTALLATION AND USE

Suitable for use with clean water and liquids that are not chemically aggressive towards the materials from which the pump is made. As a result of their quietness, these pumps are widely used in domestic applications such as the distribution of water in combination with small and medium sized pressure sets, and for the irrigation of gardens and allotments, etc. The pump should be installed in an enclosed environment, or at least sheltered from inclement weather.

### OPTIONALS AVAILABLE ON REQUEST

- Special mechanical seal
- Other voltages or 60 Hz frequency

### GUARANTEE

1 year subject to terms and conditions

**CHARACTERISTIC CURVES AND PERFORMANCE DATA**

**50 Hz n= 2900 1/min HS= 0 m**

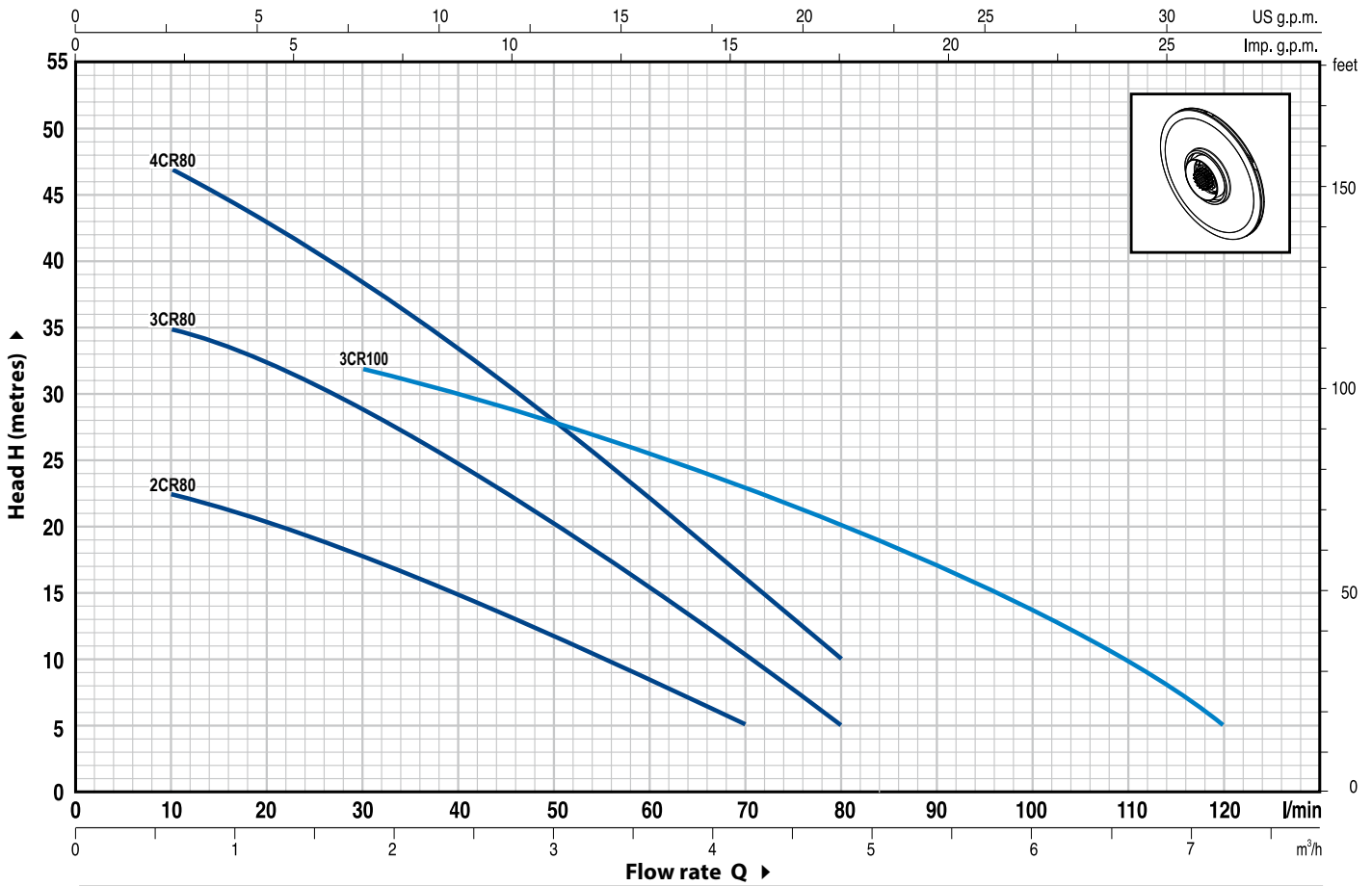

MODEL		POWER		Q	Flow rate																	
Single-phase	Three-phase	kW	HP		m³/h	0	0.3	0.6	0.9	1.2	1.5	1.8	2.4	3.0	3.6	4.2	4.8	5.4	6.0	6.6	7.2	
2CRm 80	-	0.37	0.50	H metres	0	5	10	15	20	25	30	40	50	60	70	80	90	100	110	120		
3CRm 80	3CR 80	0.45	0.60		25	24	22.5	21.5	20	19	17.5	15	11.5	8	5							
4CRm 80	4CR 80	0.60	0.85		38	36	35	34	32.5	31	29	25	20	15.5	10	5						
3CRm 100	3CR 100	0.60	0.85		50	48	47	45	43	40.5	38.5	33.5	28	22.5	16	10						
					36	35.5	35	34	33.5	32.5	32	30	28	25.5	23	20	17	13.5	10	5		

Q = Flow rate H = Total manometric head HS = Suction height

Tolerance of characteristic curves in compliance with EN ISO 9906 Grade 3.



## DIMENSIONS AND WEIGHT

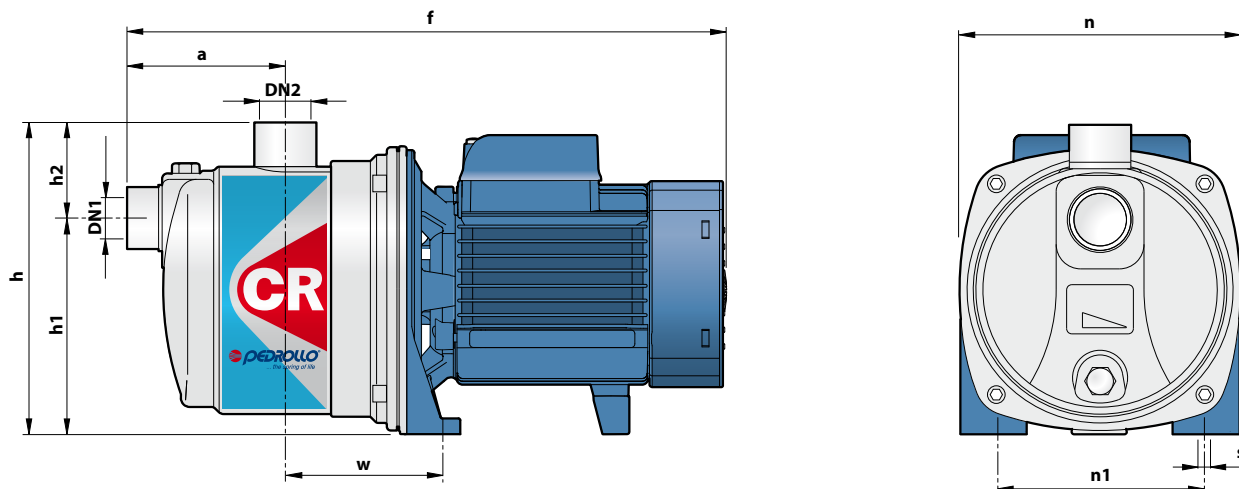

MODEL		PORTS		DIMENSIONS mm									kg	
Single-phase	Three-phase	DN1	DN2	a	f	h	h1	h2	n	n1	w	s	1~	3~
2CRm 80	-	1"	1"	90	339	174	122	52	160	120	88	9	5.9	-
3CRm 80	3CR 80												6.8	6.2
4CRm 80	4CR 80												7.3	6.8
3CRm 100	3CR 100												7.2	6.7

## ABSORPTION

MODEL	VOLTAGE (single-phase)		
	230 V	240 V	110 V
2CRm 80	2.4 A	2.4 A	4.8 A
3CRm 80	3.2 A	2.9 A	6.5 A
4CRm 80	4.0 A	3.6 A	8.0 A
3CRm 100	4.0 A	3.6 A	8.0 A

MODEL	VOLTAGE (three-phase)					
	230 V	400 V	690 V	240 V	415 V	720 V
3CR 80	2.2 A	1.3 A	0.8 A	2.1 A	1.2 A	0.7 A
4CR 80	2.9 A	1.7 A	1.0 A	2.8 A	1.6 A	0.9 A
3CR 100	2.9 A	1.7 A	1.0 A	2.8 A	1.6 A	0.9 A

## PALLETIZATION

MODEL		GROUPAGE				CONTAINER			
Single-phase	Three-phase	n° pumps	H (mm)	kg		n° pumps	H (mm)	kg	
				1~	3~			1~	3~
2CRm 80	-	98	1440	600	-	154	2180	930	-
3CRm 80	3CR 80	98	1440	690	630	154	2180	1070	970
4CRm 80	4CR 80	98	1440	730	680	154	2180	1140	1070
3CRm 100	3CR 100	98	1440	720	680	154	2180	1130	1050

