

motralec

4 rue Lavoisier . ZA Lavoisier . 95223 HERBLAY CEDEX

Tel. : 01.39.97.65.10 / Fax. : 01.39.97.68.48

Demande de prix / e-mail : service-commercial@motralec.com

www.motralec.com

NETZSCH

Mixing – Conveying – Grinding
Your partner for the energy of the future



The heart of your process. ■

NETZSCH in the Biogas Technology Products and Components



Your Partner for the Energy of the Future

Today's trend is the increasing use of the fermentation of organic matter for the economical production of energy. As your expert in biogas technology we provide specific mixing and conveyance systems for all process steps.

Biogas Technology



For the production of biogas, different processes are possible. Biogas plants belong, together with solarplants and waterpower plants, to the regenerative electricity producers (= CO₂ - neutral). Among these, biogas is one of the most multi-functional energy sources.

Electricity, heat, fuel and mains gas can be produced from biogas. The "energy" for the biogas comes from renewable energies or organic waste which, with the help of bacteria, is transformed under the exclusion of air in large part into methane.

How fortunate to be able to choose ■

For centuries rotating positive displacement pumps have been used as conveying systems for all kinds of fluids in wastewater treatment. Due to their inherent characteristics these pumps guarantee a reliable, safe and efficient process. For such applications NEMO® Progressing Cavity Pumps and NETZSCH TORNADO® Rotary Lobe Pumps are available.

Always the right product ■

For each individual application case, the technically most suitable pump is chosen. Your advantages are pump types and series, which are optimally matched to your specific application, reliable and market driven. The NEMO® and TORNADO® pumps are complemented by the NETZSCH Grinding Systems.

We are where you are ■

With more than 1300 employees at four development and production sites as well as 20 sales offices, a cooperation partner (in Japan) and another 200 NETZSCH representatives we are close to you wherever you are.

NEMO® Progressing Cavity Pumps

Standard pumps
Hopper pumps
Immersible pumps
Custom-built pumps

TORNADO® Rotary Lobe Pumps

Standard pumps
Mobile pumps
Custom-built pumps

NETZSCH Macerators

Cutting plate macerator
Twin shaft macerator

NETZSCH Accessories

Protection devices
Pressure relief valves
Controls
Trailers
Tools

Your medium We are ready for anything. ■

- Fermented renewable energies
- Process Water
- Ground biowaste and leftovers
- Pretreated slaughter waste
- Co-substrate
- Thickened substrate
- Distillers grains with solubles
- Liquid manure
- Bio waste
- Slaughter waste



We are a member of

**Fachverband
Biogas e.V.**

The heart of your process. ■

Flow chart of a Biogas Plant

Application points of



NEMO® Progressing Cavity Pumps



TORNADO® Rotary Lobe Pump



NETZSCH Macerators

Mixing – Conveying – Grinding

The flow chart represents a simplified, multi-level biogas plant for the production of methane. The fields of use of your NEMO® progressing cavity pumps, TORNADO® rotary lobe pumps as well as NETZSCH grinding systems comprise mixing, conveying and also grinding.

Renewable Energy Plants

At the beginning of the process the fermenters are loaded with the substrate. The substrate is homogenized with the process water in the B.Max™. The fermentation proceeds, at a concentration of anhydrous mass of approx. 5 - 15 %, in four biological phases. These are the hydrolysis phase, acidification phase, acetic acid phase and the methane creation phase. Through use of an upstream grinder, a higher yield of gas can be achieved. Afterwards the pre-fermented substrate is delivered into the subsequent fermenter.

Production of Electricity

The now generated methane will be supplied to a block heating station for the production of electricity or heat. The remaining biomass, still containing a residue of organic material, will be further dewatered, the extracted substrates are used agriculturally or will be finally composted.

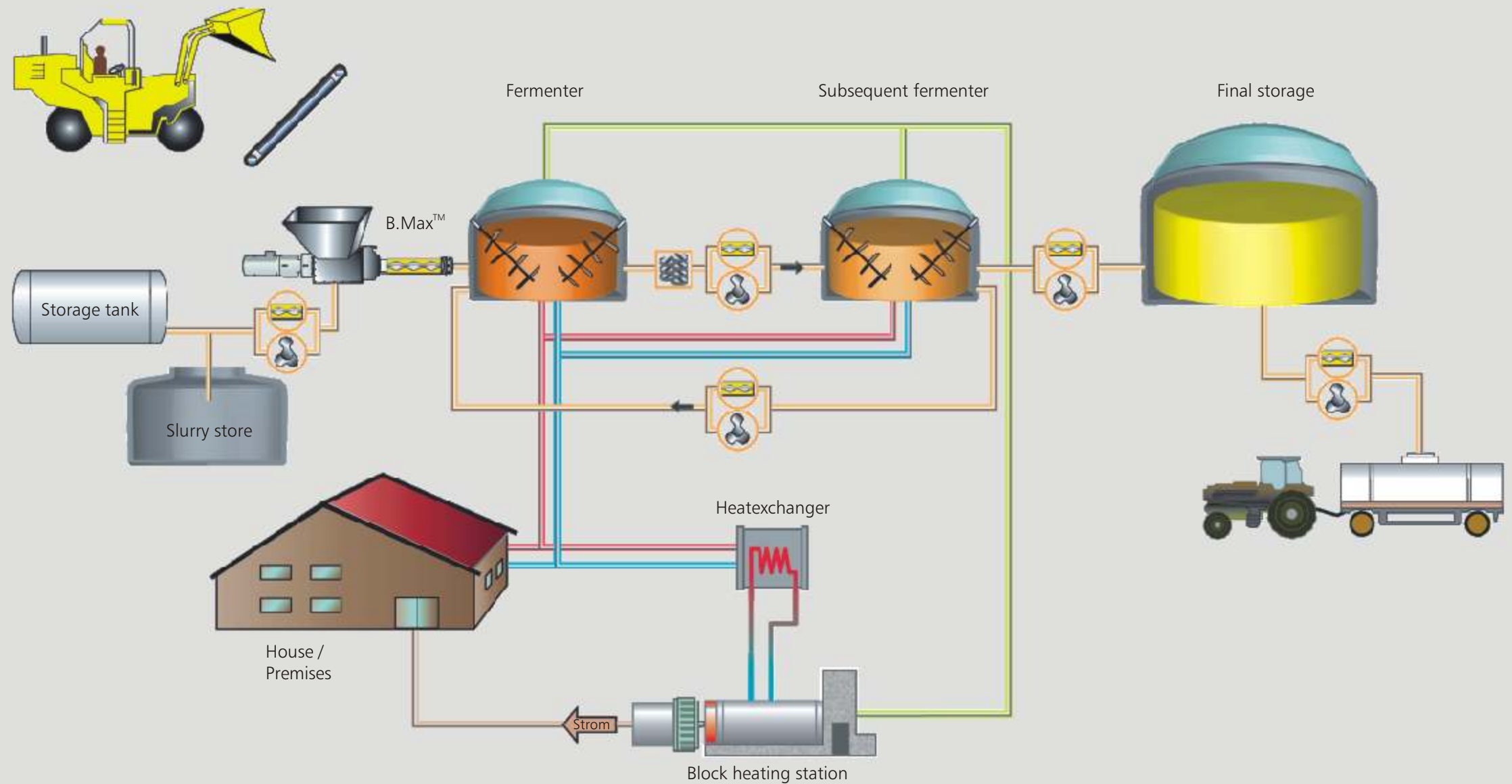

NEMO® B.Max™ – Benchmark in Blending Technology

Characteristics and Construction



Universal

The NEMO® B.Max sets new standards by ensuring maximum mixing and conveyance of your bio substrates. It is the result of a continuous further development of the NEMO® progressing cavity pump with hopper and feeding screw.

Wide Range of Application

The NEMO® B.Max™ is particularly suitable for the following media:

- Fermented renewable energies
- Liquid manure
- Process Water
- Ground biowaste and leftovers
- Pretreated slaughter waste
- Co-substrate
- Thickened substrate
- Distillers grains with solubles

Large Range of Capacities and Pressures

- capacities up to 70 m³/h
- pressures up to 48 bar

Control

We offer for each application a customised control system. The systems range from simple hand operated units up to BUS connected fully automated mixing systems with data recording.

Advantages

- Maximum homogenization of substrates
- Increased gas production
- Continuous and low pulsation conveyance independent of pressure and viscosity
- High suction and pressure capability
- Sturdy drive sealing
- Low investment and operating costs
- High operational safety

Additional Features

Pump housing with big, rectangular hopper and removable, tapered force feed chamber as well as coupling rod with patented, positioned feeding screw for optimum transfer of the product to the conveying elements. A feeding port with optimized position at the hopper housing allows for maximum mixing of substrates.

NEMO® B.Max™ in block construction design with directly flanged drive

or as NEMO® B.Max™ with bearing housing and drive shaft

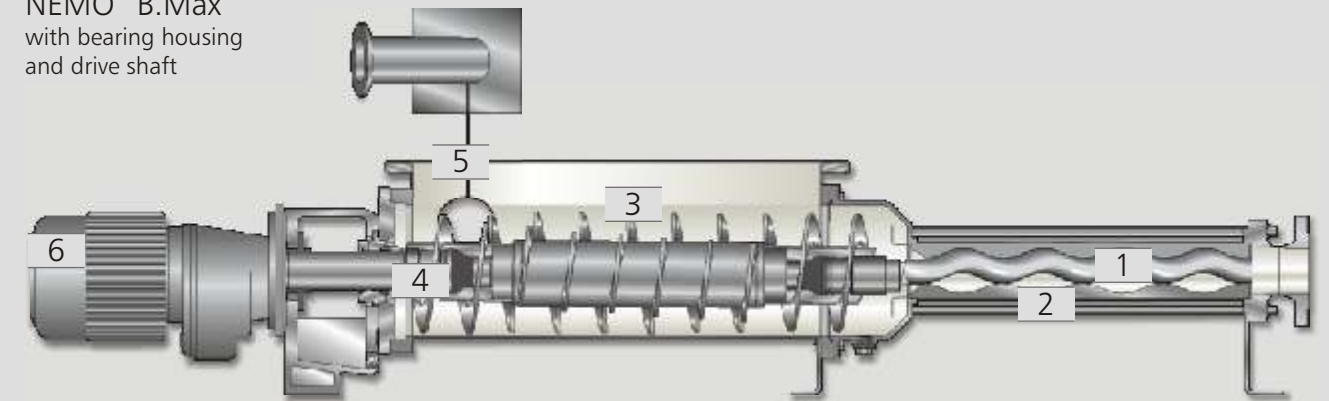

1 Rotor

Wear and corrosion resistant design

2 Stator

Vulcanised into a tube, with integrated seals on both ends, in a variety of elastomers. Stator inlet with hopper-shaped port to facilitate the entry of the fluid into the conveying chamber.

3 Mixing and conveying screw

The reinforced and offset screw blades of the mixing and conveying screw guarantee a maximum of mixing and homogenization of the media.

4 Shaft seal

Use of a standard design, robust drive sealing for highest demands on operational safety.

5 Hopper housing

The feeding port with optimized position allows for maximum mixing of substrates. Removable, tapered force feed chamber with inspection or inlet port for ease of cleaning and maintenance as well as additional feeding of media. Optional with stonetrap. Optional coating of the hopper as protection against abrasion and corrosion.

6 Drive

The compact block construction design with directly flanged drive is characterized by low investment, operating and maintenance costs.

Technical Information

Adjustment of hopper dimensions to specific applications is possible.

NEMO® Progressing Cavity Pumps Characteristics and Construction



NEMO® Pump in Block construction

Compact design with flanged drive; low investment and operating and maintenance costs. Four rotor/stator geometries for optimised performance.

Wide Range of Application

- The pumps are mainly used for conveying:
- fermented renewable energies
 - liquid manure
 - process Water
 - ground biowaste and leftovers
 - pretreated slaughter waste
 - co-substrate
 - thickened substrate
 - distillers grains with solubles

Large Range of Capacities and Pressures

- capacities from a few millilitres up to 500 m³/h
- pressures up to 48 bar

Fluid Properties

- high dry solids content
- highly abrasive
- low to high viscosity
- lubricating and non-lubricating
- corrosive (pH 0 - 14)
- heated and unheated
- dilatant, thixotropic or shear thinning
- toxic

Advantages

- continuous and low pulsation conveyance independent of pressure and viscosity
- high suction and pressure capability
- low investment and operating costs
- high operational safety
- various installation options

Further Features

- high suction capability up to 9 mwc (30 ftwc)
- reversible direction of rotation and thus flow
- installation in any position
- smooth and quiet operation
- temperatures of -20 up to + 200 °C (-5 up to +570 °F)

NEMO® BY in block construction design



optional Stator with iFD-technology



NEMO® M.Champ®

The M.Champ® sets new standards with regard to ease of maintenance and economic efficiency. The compact and simple design of the pump permits the replacement of wearing parts in no time at all. An integrated reserve stator guarantees low life cycle cost and a high degree of operational security. The new Clamp-Tec Stator quick-clamping system allows for easy reversal or replacement of the stator.

Large Range of Capacities and Pressures

- capacities up to 85 m³/h
- pressures up to 6 bar

Advantages

- compact design with good performance
- pump capacity proportional to rotational speed
- conveying direction reversible
- high suction and pressure capacity

Further Features

- continuous low pulsation conveyance independent of pressure and viscosity
- stator with flow cones for low NPSH values
- mechanical seal in the medium flow
- integrated reserve stator
- maintenance-and wear-free flexible rod
- innovative Clamp-Tec Stator quick-clamping system with attached information plate
- space-saving, robust drive system
- low life cycle cost
- ease of service

NEMO® M.Champ® in block construction design with maintenance free flexible rod and integrated reserve stator

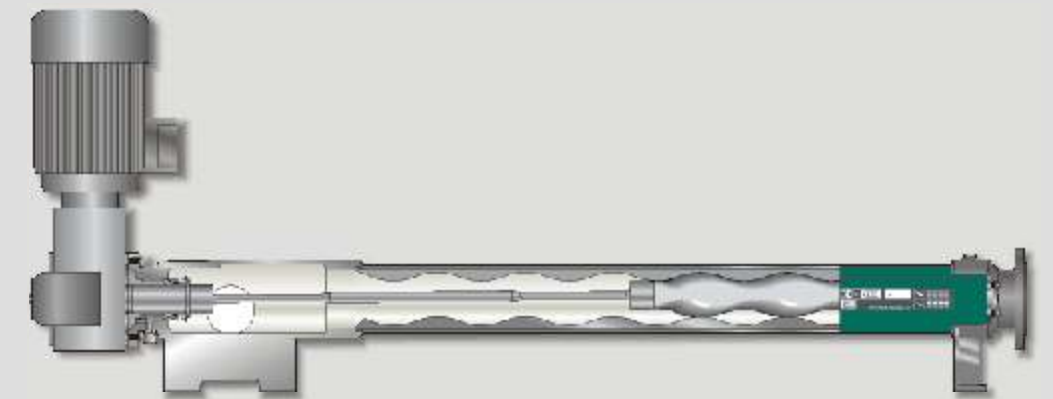

TORNADO® Rotary Lobe Pump / M-Ovas® Macerator

Characteristics and Construction



Wide Range of Applications

- NETZSCH TORNADO® Rotary Lobe pumps are normally used for conveying:
- fermented renewable energies
 - liquid manure
 - process Water
 - co-substrate
 - distillers grains with solubles
 - ground biowaste and leftovers

Large Range of Capacities and Pressures

- capacities up to 1000 m³/h
- pressures up to 6 bar

Mobile design

The TORNADO® rotary lobe pump on a mobile trailer with diesel or electric drive allows pumping large quantities of substrate.

Advantages

- insensitive to foreign matter (free passage for up to 70 mm dia.)
- dry solids content up to 7%
- low to high viscosity
- limited installation space and highly efficient
- continuous conveyance
- high suction and pressure capability
- sturdy drive sealing
- low investment, operating and maintenance costs
- high operational safety
- insensitive to dry running
- installation in any position

NETZSCH TORNADO®
Rotary Lobe Pump

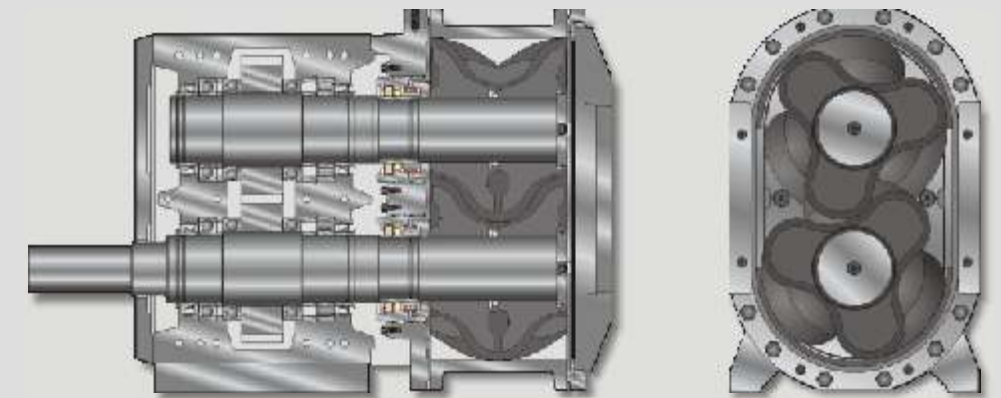

Universal Use

To prevent blockage of pipelines and of downstream equipment, the solids contained in the fluid are ground by the NEMO® M-Ovas®.

Wide Range of Applications

- M-Ovas® is mainly used for grinding of the fluids below:
- fermented renewable energies
 - liquid manure
 - bio waste
 - slaughter waste

High delivery capacities

- flow capacities up to 300 m³/h with up to 15 % dry solids content

Advantages

- compact design for high flow rates
- easy and fast disassembly of cutting plate and blade unit
- high gas yield
- low energy demand at high flow rates
- integrated stone trap with separate clean-out and drain ports
- easy access allows simple disposal of the sediment
- Self-adjusting blades ensure optimum cutting performance
- sealing by means of a mechanical seal with grease lubrication
- different perforated plates depending on the particular use
- increased operational safety

NETZSCH M-Ovas®
Macerator

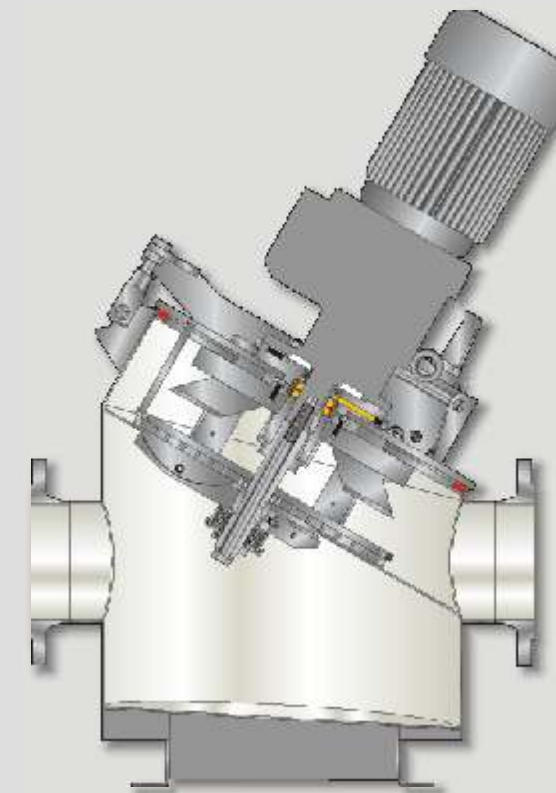

For further information of TORNADO® Mobile simply order brochure NMP • 045/02
For further information of NETZSCH Macerator M-Ovas® simply order brochure NMP • 040/02

Process monitoring

NETZSCH Dry Running and Over-/Underpressure Protection devices avoid thermal destruction of stators and protect the pump and accessory equipment from unsuitable pressures. These devices continuously measure the stator temperature, as well as suction/discharge pressures, therefore increasing the operating reliability of the pump and minimising downtime.

- Diaphragm Pressure Gauge G3/4 Inch connection
- Diaphragm Pressure Gauge with DN50/PN40 flanged connection
- Dry Running protection for NEMOLAST® Stators
- Flow sensing unit for solid stators
- Multi Function Pressure Instrument
- Pressure Control Device DTSL 3
- Speed monitoring device

NETZSCH Controls

- Frequency Inverters
- Motor Protection Devices
- Pressure Transducers
- We offer for each application a customised control system. The systems range from simple hand operated units up to BUS connected fully automated mixing systems with data recording.

Protection Units and Trolley Assemblies

- Covers for drive motors
- Fixed wheels
- Machine feet elastic, star
- Pulling handle in stainless steel
- Steerable Wheels
- Trolley Assemblies
- Wheel mounting plates

NETZSCH Optional Equipment, Fittings/Hoses and Tools

- Adjustable Feet and Foundation Bolts
- Adjustable Stator with Adjusting Device (NEMO® pump)
- Automatic Shut-off Devices, Valves, non return Valves
- Bypass Tubing with Control Switch or Pressure Relieve Valve
- Connecting, T and Welding Neck Flanges
- Custom-engineered Hoppers
- Coupling Rod with mixing/agitator Blade (NEMO® pump)
- Covers for Drives
- Heating Jacket
- Hoses and Hose Connections
- Mobile and Trailer mounted Units
- Pressure relieve Valve
- Ring Dosing Nozzle
- Seal Support Systems and Buffer Fluid Systems for Mechanical Seals
- Special Tools
- Stone Trap for heavy Solids
- Vibration Dampener

NETZSCH Seminars for Users

Know-how and competence for your staff

Your benefit

- trained personnel for handling NETZSCH pumps
- avoid mistakes with installation and commissioning
- save costs by preventive maintenance and professional repairs
- save time when analysing damage and restarting pumps
- optimise your stock of NETZSCH Genuine Spare Parts

For more information, visit

www.netzsch.com

or contact your local business partner.

NETZSCH customers are entitled to the best service – We see to that!

To us, NETZSCH service is of equal importance as the quality of our pumps.

From planning via process monitoring

Consulting, service and quality are our strengths. When buying the pump you have decided on a quality product by NETZSCH with good reason.

In order to maintain the capacity and quality of your pump, we will support you in all matters, also after the delivery of the pump.

Skilled sales and service staff located near your site are at your disposal around the clock.

Process reliability

NETZSCH service together with quality and genuine parts ensure reliable operation of the pump in your plant. The experience from more than 500,000 pumps installed is the basis for this.

Availability

Five production sites guarantee immediate supply of parts in all regions of the world.

Mounting, installation, after sales service – simply ask our service team!

Around the clock on 7 days a week through our

Service-Hotline
+49 172 6725573

In your area well-trained service partners are available for quick and economic service of the pumps at your premises. You will find your personal service partner in our homepage

www.netzsch.com

or by our service team.

Quality

Strict quality standards, tests and the certification according to DIN EN ISO 9001 guarantee all parts are of a consistent quality to the highest degree.

Registered Trademarks TM and ®

- The heart of your process
- NETZSCH, NEMO
- NEMO PUMPEN
- NEMO CERATEC
- iFD-Stator, NEMOLAST
- SBBPF, EPBPF, SM, NE, NM
- TORNADO, M-Ovas, aBP-Module
- M.Champ, C.Pro, B.Max
- pMT-Pilot, N-Ipos, N-Elor

NETZSCH

motralec

4 rue Lavoisier . ZA Lavoisier . 95223 HERBLAY CEDEX

Tel. : 01.39.97.65.10 / Fax. : 01.39.97.68.48

Demande de prix / e-mail : service-commercial@motralec.com

www.motralec.com
