

MP PUMPS, INC.

FRX 75-SP

Centrifugal Pump

Model FRX 75-SP is a high performance self-priming 316 stainless steel centrifugal pump. The pump is ideal for marine, industrial, agricultural or commercial applications where suction lift is required.

The FRX 75-SP model features all 316 stainless steel components for superior corrosion resistance when pumping chemical compounds. A carbon/ceramic/viton bellows shaft seal is standard. Ports are 3/4" NPT with 1/8" NPT fill port. The O-ring/flapper design enhances the self-priming capability to 12 foot suction lift. Marine ignition protected motors available.

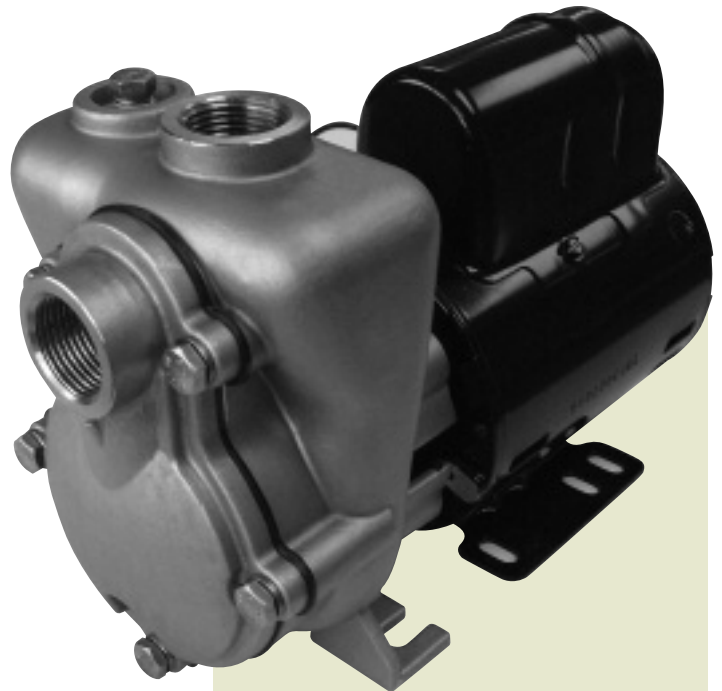

SPECIFICATIONS:

Housing	316 Stainless Steel (Investment Cast)
Cover	316 Stainless Steel (Investment Cast)
Impeller	316 Stainless Steel Semi-Open (Sintered PM)
Wear Plate	316 Stainless Steel
Mechanical Seal . .	Carbon/Ceramic/Viton Bellows 150 PSI Special Seals Upon Request
O-ring/Flapper . . .	Viton
Motor	12V DC and 24V DC 115V AC ODP and TENV 230V AC TENV
Weights	Pump W/AC Motor 18 lbs. Pump W/DC Motor 12 lbs.

Application:

- Marine
- Industrial
- Commercial

Construction:

- 316 Stainless Steel Investment Cast

Motor Options:

- AC
- DC

Port Sizes:

- 3/4" NPT
- 1/8" NPT Fill Port

Seal:

- Carbon / Ceramic / Viton

motralec

4 rue Lavoisier . ZA Lavoisier . 95223 HERBLAY CEDEX
Tel. : 01.39.97.65.10 / Fax. : 01.39.97.68.48
Demande de prix / e-mail : service-commercial@motralec.com

www.motralec.com

FRX 75-SP

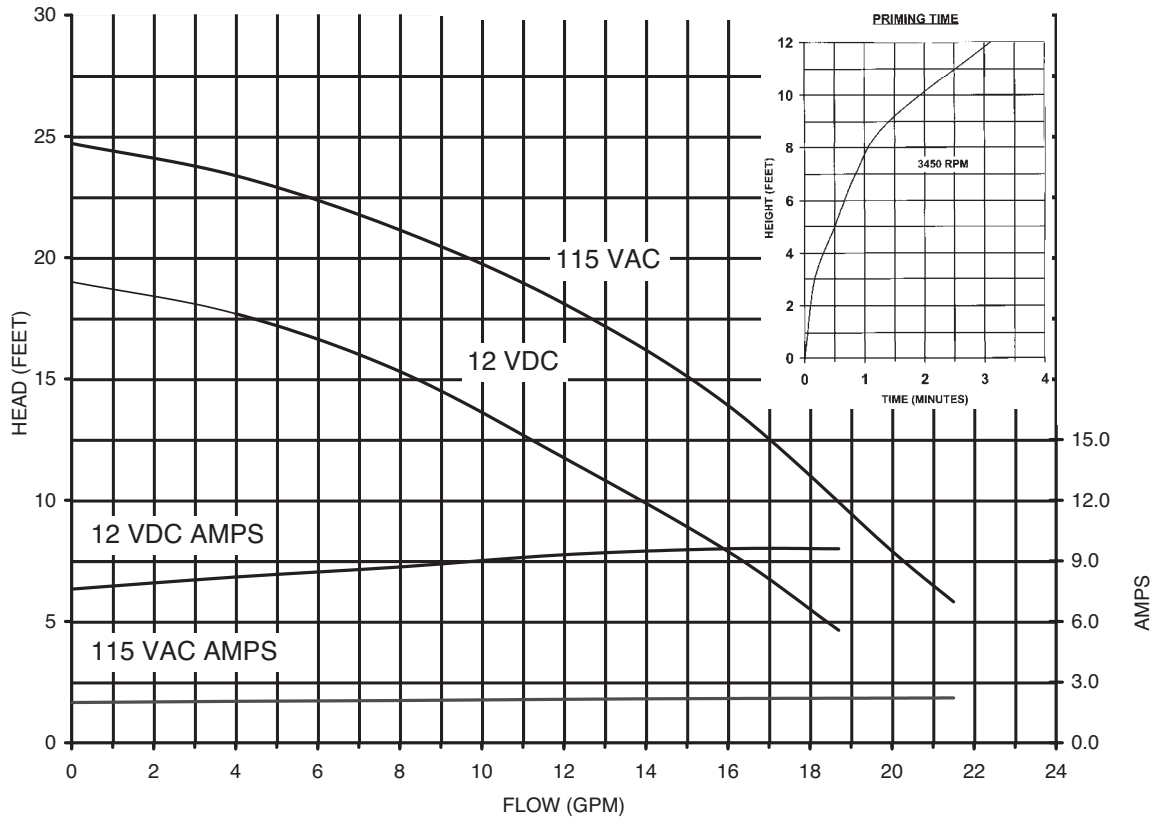
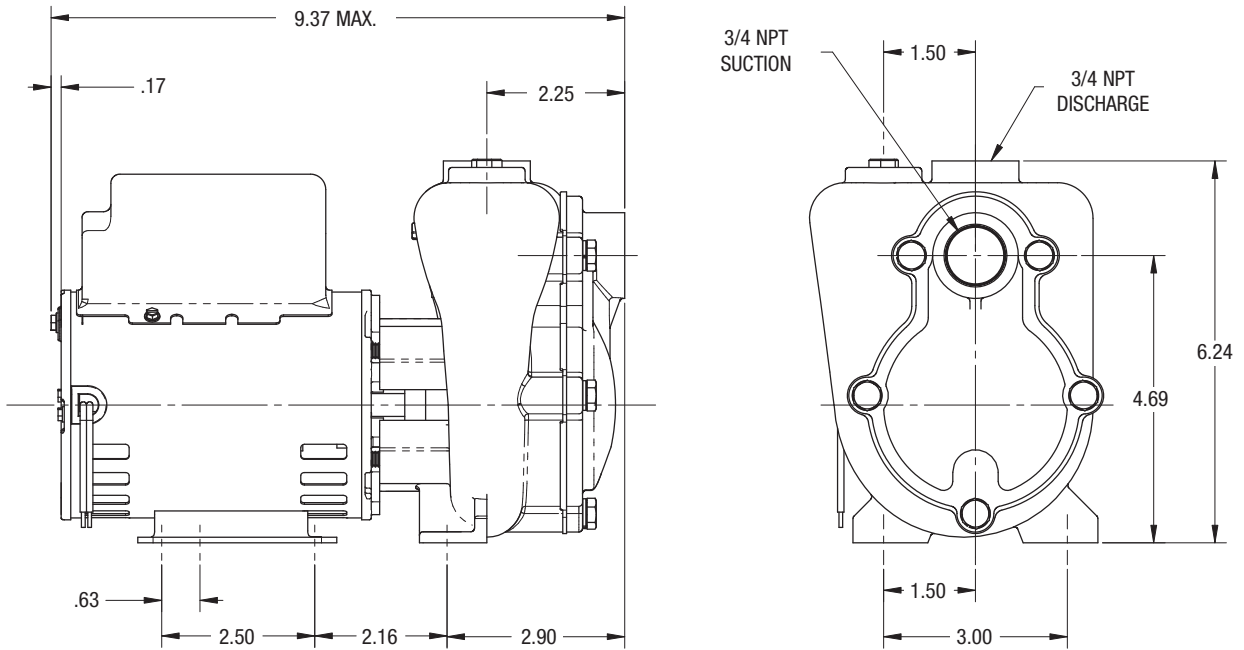

motralec

4 rue Lavoisier . ZA Lavoisier . 95223 HERBLAY CEDEX

Tel. : 01.39.97.65.10 / Fax. : 01.39.97.68.48

Demande de prix / e-mail : service-commercial@motralec.com

www.motralec.com