

CHEMFLO[®]

5 - 8

Hydraulic Drive
Stainless Steel
Centrifugal Pumps

4 Pumps

2 Motors

Mount Anywhere

Remote Control

No Alignment Required

CHEMFLO 5,6,7,8 hydraulic driven pumps are available with two hydraulic motor displacement options. The hydraulic motor is close-coupled to the bearing frame with a standard SAE B flange and driven with a 13-tooth shaft.

PUMP SPECIFICATIONS

Flanges	150# Class
Housing	316 Stainless Steel
Impeller	Enclosed 316 Stainless Steel
Seal Plate	316 Stainless Steel
Shaft Sleeve	316 Stainless Steel
Seal	Viton / carbon / ceramic Optional seals are available
O'Ring	Viton or teflon optional
Bearings	Grease lube 6309
Hydraulic Motor	Gear type, Commercial Intertech, pressure balanced, cast iron, bi-rotational

CHEMFLO 5 2" X 1 1/2" X 6"

CHEMFLO 6 3" X 2" X 6"

CHEMFLO 7 2" X 1" X 8"

CHEMFLO 8 3" X 1 1/2" X 8"

FLOW RATE UP TO 500 GPM
PRESSURE UP TO 340 FEET

OIL FLOW RATE UP TO 28 GPM

OIL PRESSURE UP TO 2500 PSI

HYDRAULIC MOTOR
STANDARD SAE "B"
SPLINE SHAFT

AVAILABLE WITHOUT THE
HYDRAULIC MOTOR

motralec

4 rue Lavoisier . ZA Lavoisier . 95223 HERBLAY CEDEX

Tel. : 01.39.97.65.10 / Fax. : 01.39.97.68.48

Demande de prix / e-mail : service-commercial@motralec.com

www.motralec.com

FORM 8104

CHEMFLO 5-8

HYDRAULIC MOTOR SPECIFICATIONS

Model Number: 2TR019
Displacement: 1.16 IN³/REV
Max. Oil Flow: 20 G.P.M.
Max. Oil Pressure: 3000 P.S.I.
Max. Back Pressure: 150 P.S.I.
Seal (Lip): Viton
Hydraulic Connections: 1 1/16-12 SAE O'Ring

Model Number: 2TR026
Displacement: 1.59 IN³/REV
Max. Oil Flow: 30 G.P.M.
Max. Oil Pressure: 3000 P.S.I.
Max. Back Pressure: 150 P.S.I.
Seal (Lip): Viton
Hydraulic Connections: 1 1/16-12 SAE O'Ring

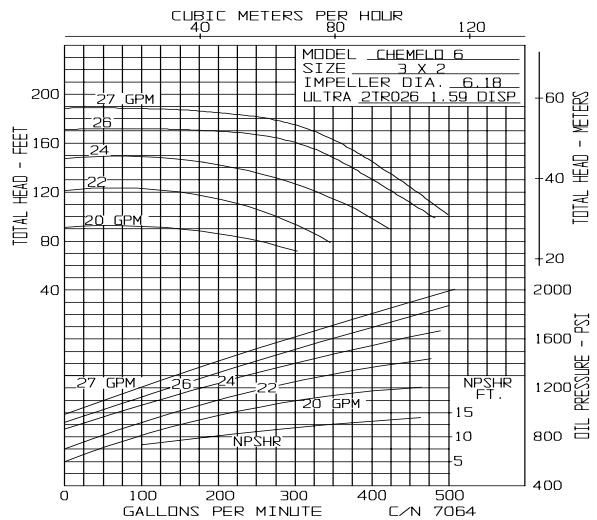
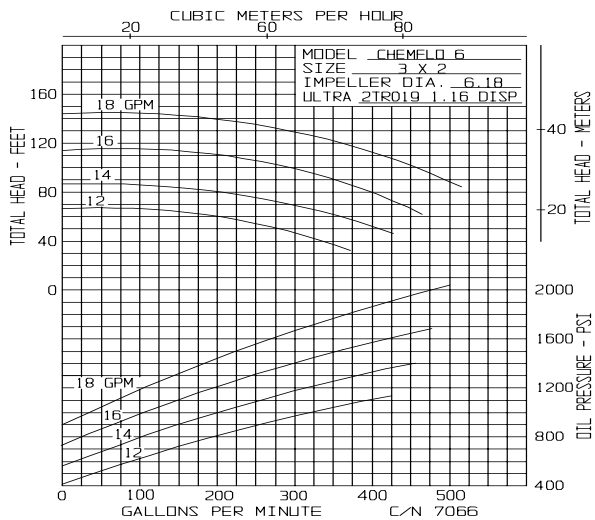
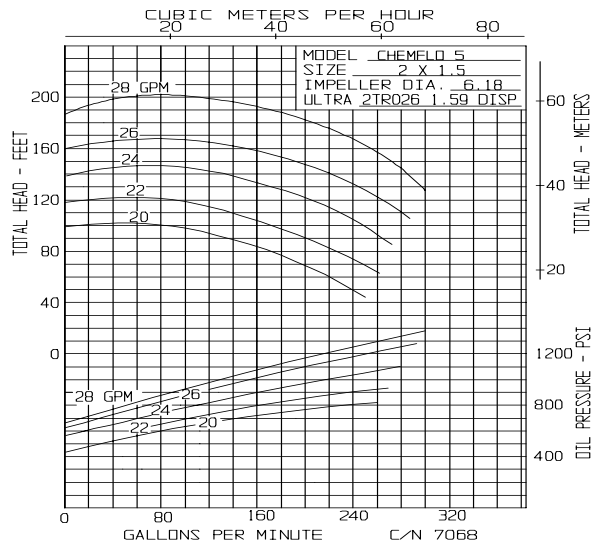
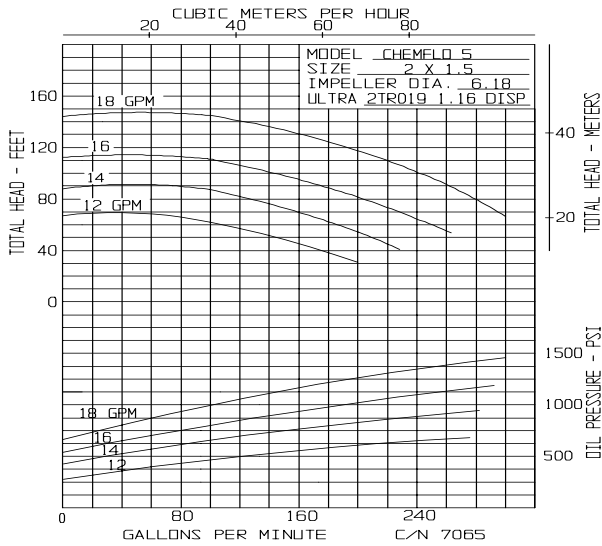

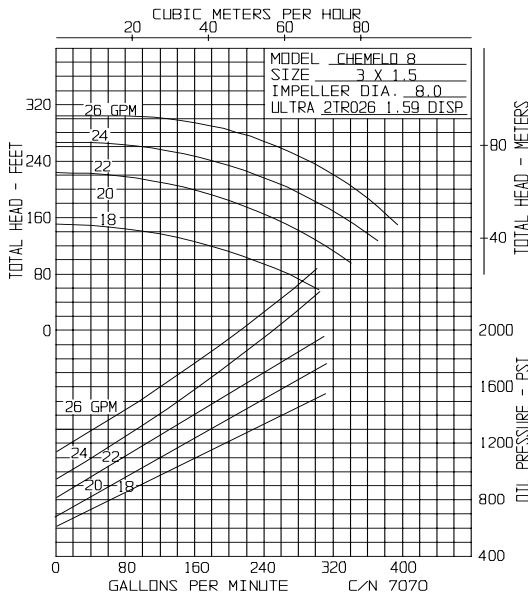
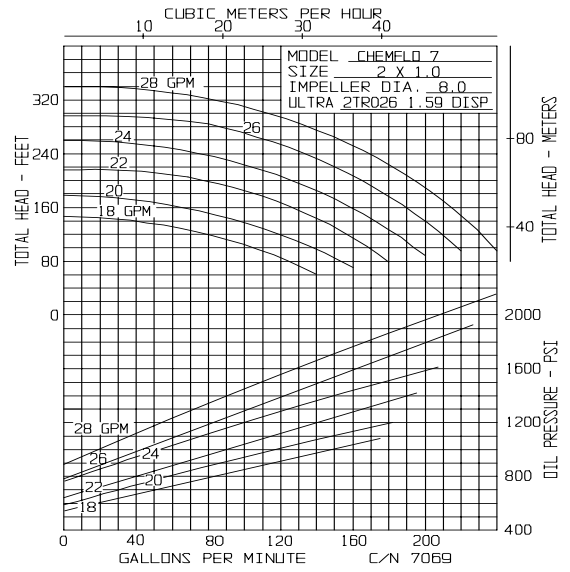
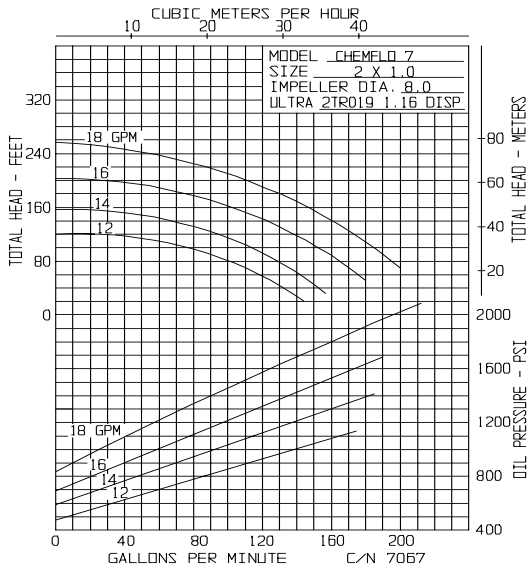

PUMP	CF5	CF6	CF7	CF8
SIZE	2 X 1.5 X 6	3 X 2 X 6	2 X 1 X 8	3 X 1.5 X 8
FLOW (GPM)	300	500	200	400
TDH (FT)	200	160	320	280

OPTIONAL SEALS

- TYPE 9 - CARBON CERAMIC TEFLON
- TYPE 2 - SILICON CARBIDE VITON
- TYPE 21 - CARBON CERAMIC VITON

TYPICAL PERFORMANCE

10WT INDUSTRIAL OIL
 120 - 180° F OIL TEMPERATURE

WHEN PUMPING LIQUIDS HEAVIER THAN WATER, PRESSURE WILL INCREASE DIRECTLY PROPORTIONAL TO THE SPECIFIC GRAVITY.

MAXIMUM WORKING PRESSURE NOT TO EXCEED 200 PSI.

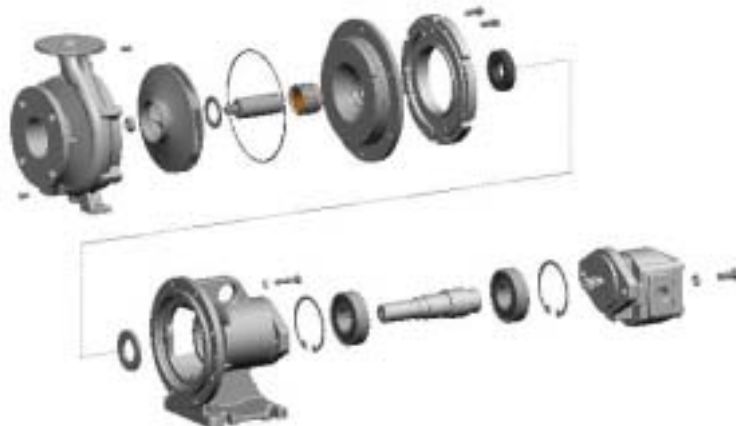

CHEMFLO 5
2TR019

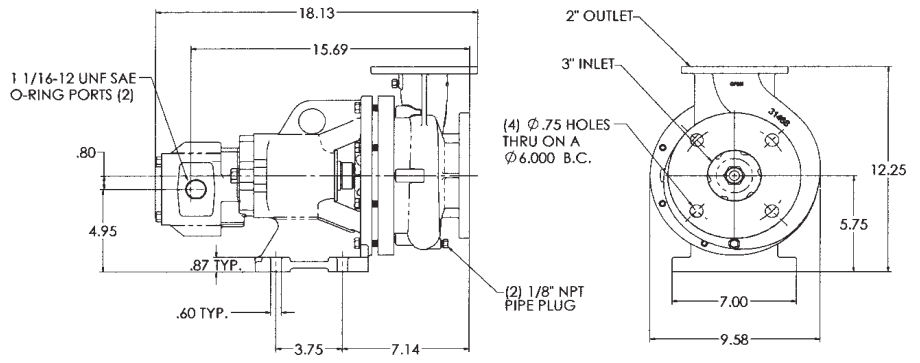

CHEMFLO 6
2TR019

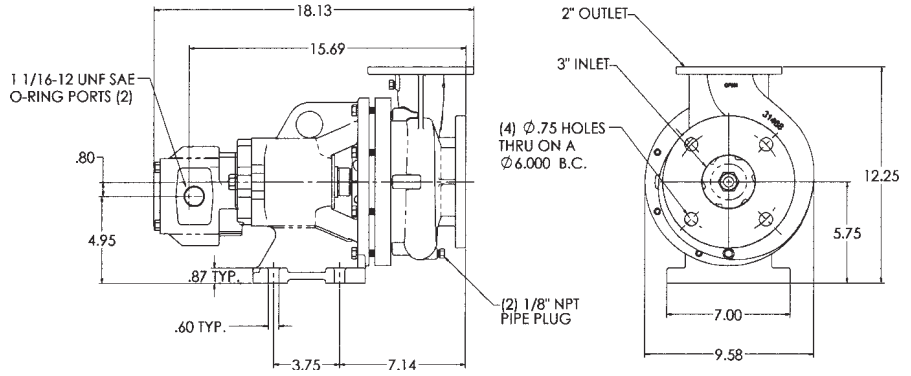

CHEMFLO 7
2TR026

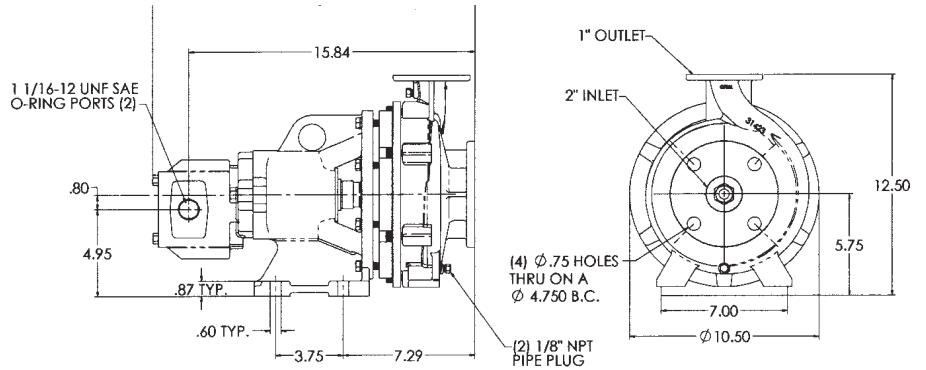

CHEMFLO 8
2TR026

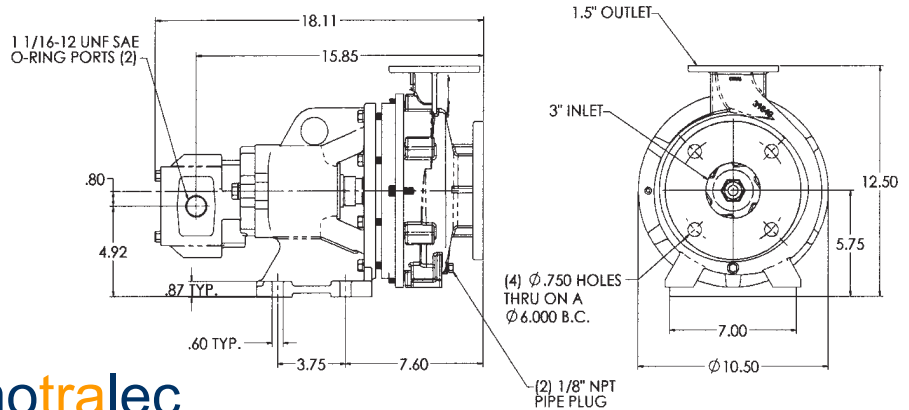

motralec

4 rue Lavoisier . ZA Lavoisier . 95223 HERBLAY CEDEX

Tel. : 01.39.97.65.10 / Fax. : 01.39.97.68.48

Demande de prix / e-mail : service-commercial@motralec.com

www.motralec.com

FORM 8104