

**motralec**

4 rue Lavoisier . ZA Lavoisier . 95223 HERBLAY CEDEX  
Tel. : 01.39.97.65.10 / Fax. : 01.39.97.68.48  
Demande de prix / e-mail : [service-commercial@motralec.com](mailto:service-commercial@motralec.com)

[www.motralec.com](http://www.motralec.com)

KRAL Pumps with Magnetic Coupling  
for Marine Applications.

**KRAL**



# KRAL Pumps with Magnetic Coupling for Marine Applications

## No more problems with mechanical seals.



### Keep your engine room clean.

Heavy fuel oil leakage increases the risk for accidents.

KRAL screw pumps with magnetic couplings are hermetically sealed. The magnetic couplings never leak. The site stays clean and safe.

KRAL pumps with magnetic couplings are an innovative contribution for companies going into 'GreenShip technology'.



### Prevent pump failure.

The residue of heavy fuel oil can cause a pump to fail.

To reduce friction, the faces of the mechanical seal rely upon the pumped liquid for lubrication. The pumped liquid comes in contact with the atmosphere as it moves across the sealing faces. When the liquid is heavy fuel oil, it reacts with the oxygen in the atmosphere to form carbon deposits. These residual deposits build up in the connecting frame causing additional damages to the bearing. The damaged bearings run hot, and the elastomeric coupling may also melt. The pump then fails.

KRAL magnetic couplings are hermetically sealed. The fuel does not come into contact with the atmosphere and there is no build-up of residue.

## Comparing a magnetic coupling with a mechanical seal.

	Magnetic coupling	Mechanical seal
Maintenance interval:	40.000 hours	10.000 hours
Temperature:	250 °C	150 °C
Easy to convert:	It is quick and easy to convert to KRAL pumps with magnetic couplings. In virtually all cases, the dimensions for the pipework and for installation are the same.	
Costs:	It takes a maximum of three years to amortize the additional costs for magnetic coupling.	



### Guarantee on-board safety.

The International Maritime Organization (IMO) requires in its International Convention for the Safety of Life at Sea (SOLAS) the high pressure piping to be jacketed. In opposition to this requirement a leakage in the low pressure piping is tolerated.

With the KRAL magnetic coupling, this additional sealing safety can also be transferred to the pumps.

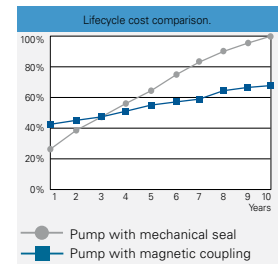

### Reduced life cycle costs.

Spare parts and maintenance costs of mechanical seals increase life cycle costs.

The use of high quality mechanical seals in KRAL screw pumps is the standard. Even when properly applied, mechanical seals are subject to wear. Spare parts and maintenance costs arise.

KRAL magnetic couplings are maintenance free. Extended bearing life compared to mechanical sealed pumps. The cost premium of a pump with a magnetic coupling will be typically amortized after only three years of operation.



#### **Overload protection.**

If the operating limits are exceeded, the pump may become damaged.

Solids in the fluid can lead to blockade and damage the spindle and the housing. In most cases the final manufactured product is not to specification, and the pump must be replaced. If the decoupling is controlled, and the pump stops, the pump and magnetic coupling will suffer no damage.

The magnetic coupling can prevent consequential damage.

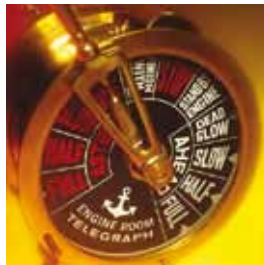

#### **Engine failure.**

If the booster module pumps fail, the diesel engines can cut out and the ship will be unable to maneuver.

Up until now, tanks have contained heavy fuel oil of 380 mm<sup>2</sup>/s, but a trend towards 500 mm<sup>2</sup>/s fuel is now common. These residual oils must be preheated to 180 °C instead of the previous 150 °C. The higher temperature is required to achieve the proper injection viscosity. These high temperatures will damage mechanical seals resulting in pump failure.

Magnetically coupled KRAL pumps can be used at temperatures of up to 250 °C.



#### **Prevent pump damage due to incorrect startup.**

Running the pump dry will damage the mechanical seal and result in leakage.

Each mechanical seal needs positive lubrication. Venting and filling are an essential part of startup. If the system is not vented, the mechanical seal will quickly run dry and may start to leak.

KRAL magnetic couplings provide additional security if the pump is not started properly and help to avoid expensive lay-off periods.



#### **KRAL – The marine specialists.**

KRAL provides a variety of solutions for marine applications:

- Magnetically coupled pumps for transfer and circulation pumps in the booster module.
- Pumps with mechanical seals as fuel and lubricating oil pumps in ships packages.
- Magnetically coupled pumps in KRAL stations for marine burners that also run on heavy fuel oil. In the burner, the magnetic coupling again has advantages with regard to temperature stability and the prevention of heavy fuel oil residues.
- Pumps for hydraulic applications, as for winches, for example.

**Optimum safety and significantly reduced operating costs.**

**High capacity rates.**

KRAL pumps with magnetic couplings are available for flow rates up to 2.900 l/min.

**No fuel residue.**

Because the magnetic coupling is sealed, the fuel does not come into contact with the atmosphere. The heavy fuel oil cannot react with the oxygen in the air to form carbon deposits that can damage the ball bearing. This eliminates one of the major causes of pump failure.

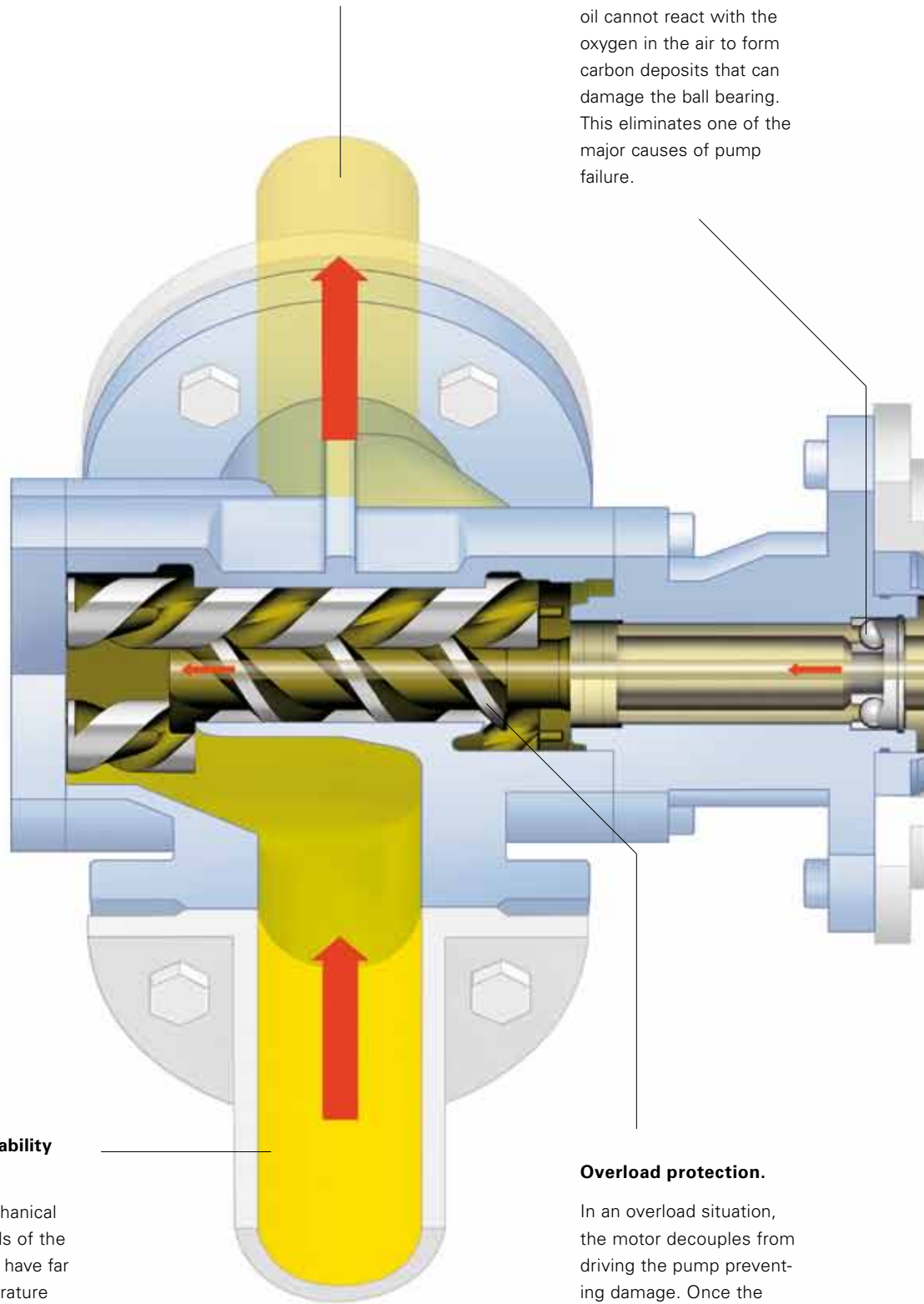

**Temperature capability to 250 °C.**

Compared to mechanical seals, the materials of the magnetic coupling have far better high temperature capability. High viscosity heavy fuel oils that must be preheated to 180 °C can be pumped without risk.

**Overload protection.**

In an overload situation, the motor decouples from driving the pump preventing damage. Once the motor is fully stopped the magnetic coupling will synchronize and the pump can be restarted.

**Function.**

The rotation of the electric motor is transferred through the magnetic coupling to the pump spindles without contact. The electric motor and the pump shaft each have a rotor with several magnets. During operation, the two rotors run in synchronized rotation.

**Hermetically sealed.**

The containment can is the sealing element of the KRAL pump. It encapsulates the pump shaft and inner magnet hub. If, in the illustration, you cover the outer rotor on the shaft of the electric motor, the fully-encapsulated nature of the pump becomes apparent.

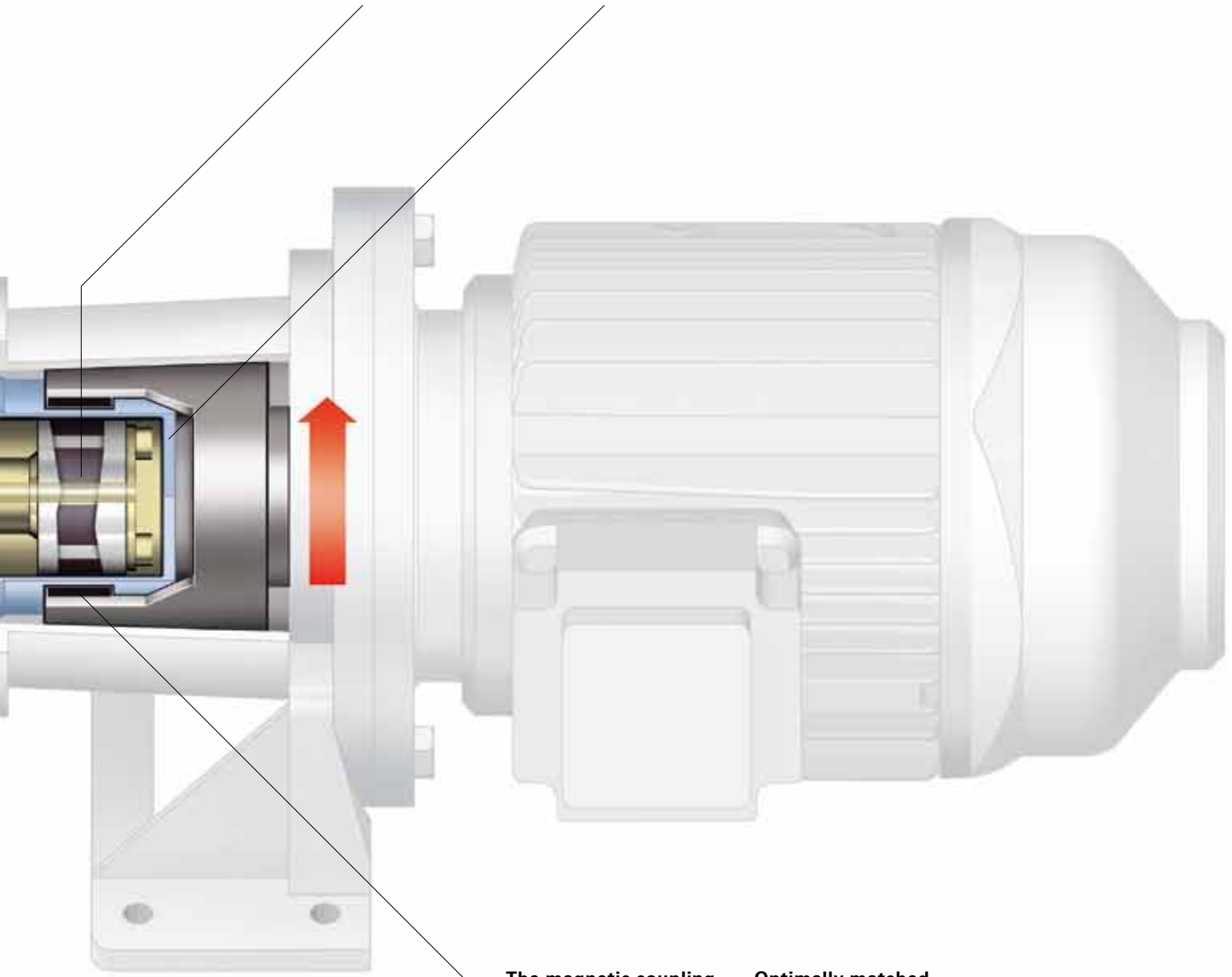

**The magnetic coupling has no wear.**

The magnetic coupling is a contact free component. The pump spindles are driven without contact by the magnets on the outer and inner rotor. As there is no friction, there is no wear.

**Optimally matched design.**

KRAL has been making magnetically coupled pumps for many years. We manufacture the components to our design standards. This means that the magnetic coupling perfectly matches the requirements of the KRAL screw pump.

**Advantages.**

Compared to other types of pump, KRAL screw pumps provide fast delivery rates in restricted spaces. Delivery is low in pulsation and quiet.

## Protect life on-board ship – eliminate the risk of fire.

To comply with the provisions of SOLAS, high pressure fuel lines must be jacketed. This precaution prevents the escape of flammable and combustible liquids.

Pumps are not required to be jacketed. Despite compliance with the SOLAS safety regulations, there exists a fire risk.

### Magnetic couplings provide optimum safety.

To close the safety gap, KRAL recommends pumps with magnetic couplings. The containment can of the magnetic coupling is a totally secure barrier:

- Fuel cannot escape, as the pump is leak free.
- The fire risk is effectively reduced.

### SOLAS, Part B, Regulation 4.

The International Convention for the Safety of Life at Sea, known as SOLAS, describes the precautionary measures to be required to prevent fire and explosion. The important points for the pump environment are Nos. 2.2.5.2 and 2.2.6.1.

**2.2.5.2.** "External high-pressure fuel delivery lines between the high-pressure fuel pumps and fuel injectors shall be protected with a jacketed piping system capable of containing fuel from a high-pressure line failure. A jacketed pipe incorporates an outer pipe into which the high-pressure fuel pipe is placed, forming a permanent assembly. The jacketed piping system shall include a means for collection of leakages and arrangements shall be provided with an alarm in case of a fuel line failure."

**2.2.6.1.** "Surfaces with temperatures above 220 °C which may be impinged as a result of a fuel system failure shall be properly insulated."

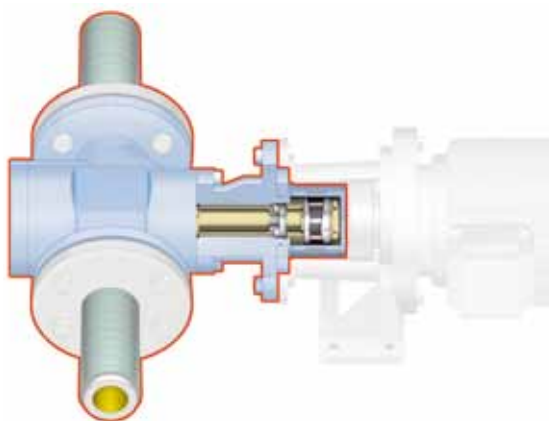

### Advantage:

The containment can of the magnetic coupling effectively closes the sealing line between the pipelines.

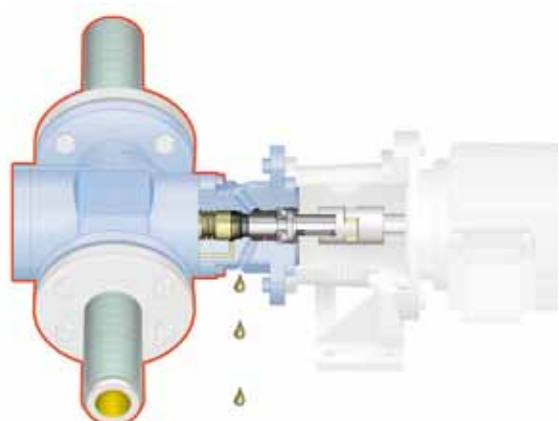

### Disadvantage:

The nominal leakage of the mechanical seal interrupts the sealing line.

## Easy conversion to magnetically coupled pumps.

To assure ease in the conversion from KRAL pumps with a mechanical seal to KRAL pumps with a magnetic coupling, KRAL provides conversion kits that maintain the dimension of the pedestal mounting and piping connection. There are however 2 factors that could require mounting modification for magnetically coupled pumps:

- A new KRAL flange to take a VDMA connecting frame.
- A larger electric motor to compensate for the power dissipation of the magnetic coupling may be required.

All KRAL conversion kits are supplied pre-assembled. The variations are shown in the illustrations on the right.

All inclusive.

### Mounting of pump unit.

The appropriate pedestal is fitted to the pump.

### Dimension

#### specification tables.

Are included in the conversion package.

### 2-D and 3-D CAD data.

Integrate the new pump unit into your system drawing. This is available on CD at your request.

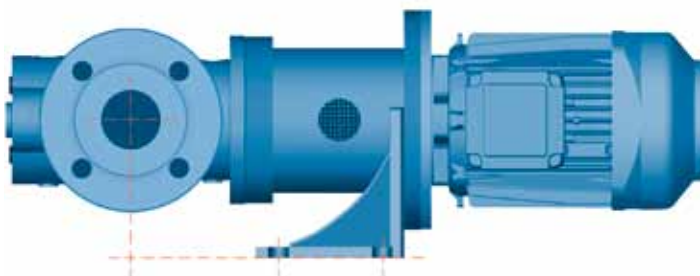

**Initial situation:** Current KRAL pump with mechanical seal.



**Conversion situation 1:** The electric motor is unchanged: the same output and size. The KRAL flange to take the VDMA connecting frame makes the unit a bit longer. The pump pedestal is the same as it was for the pump with a mechanical seal. The pipe connection dimension is the same. The change in length is compensated by adapter sleeves, so that the pedestal mounting dimension is retained.

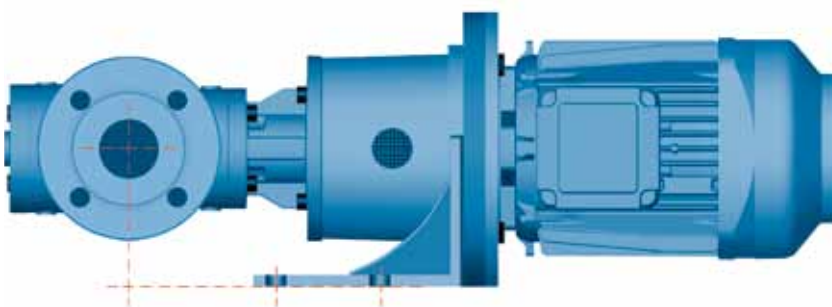

**Conversion situation 2:** The next larger size electric motor is required. KRAL makes and fits a special pedestal to allow the pedestal mounting dimension and the piping connection dimension to be retained. Adapter sleeves are not required for this situation.

**KRAL pumps with magnetic couplings for marine applications.**



<b>Technical data.</b>	Delivery rate	Pressure	Temperature
<b>Series.</b>			
<b>K</b>	2.900 l/min	16 bar	250 °C
<b>M</b>	400 l/min	40 bar	250 °C
<b>C</b>	660 l/min	100 bar	250 °C

<b>Application.</b>	Transfer pumps	Circulation pumps	Marine burners
<b>K</b>	•	•	•
<b>M</b>		•	•
<b>C</b>		•	•

Product brochures and other sizes available upon request.



## KRAL pumps with magnetic couplings in practical use.

### Manufacturers of booster modules.



Medium: Heavy fuel oil (HFO).  
Delivery rate: Up to 660 l/min.  
Pressure: Up to 16 bar.  
Temperature: Up to 180 °C.  
Viscosity: 3 to 760 mm<sup>2</sup>/s.

HFO must be preheated to 130 °C for combustion. Current pumps are therefore specified for 150 °C. Manufacturers of booster modules are now requiring higher temperatures. The reason for this is the higher-viscosity HFO made from residual oils, which also may contain abrasive silicates that may damage the mechanical seals.

KRAL pumps with magnetic couplings work at temperatures of up to 250 °C without difficulty and are less sensitive to the abrasive materials.

### Shipowners.



When the fuel supply fails, ships can be rendered incapable of maneuvering. This situation can threaten the shipowners' image and potentially threaten their very existence. This is the reason why a major European shipowner has begun a replacement program. Pumps with mechanical seals have been replaced with KRAL pumps with magnetic couplings.

KRAL pumps with magnetic couplings are now the standard for any new constructions: Greater reliability and reduced maintenance costs are the result. Shipowners who are particular in demanding high quality and economic efficiency, do not leave the choice of pump to the shipyard. They set the standards themselves.

### Ship suppliers.



Screw pumps for the in-board package:  
 Feed pumps.  
 Circulation pumps.  
 Booster pumps.

KRAL has excellent partnership relationships with the most important ship suppliers in Germany and Norway.

Complete pump programs, price/performance ratios, quality, application know-how and in particular meeting deadlines are important criteria for ship suppliers. If a supplier is late with a delivery, the package supplier must provide preliminary finance for the component suppliers. KRAL customers are always writing to confirm that compared to their rivals, KRAL is astonishingly good at keeping to on time deliveries.

### Joint projects.



Our business partners are particularly appreciative of their cooperative collaboration with KRAL. From best-possible support to the successful conclusion of the project, friendly business relations are always the order of the day. We take the time to talk to our customers and collaborate closely with them on technical matters. You can rely on KRAL.



# KRAL

**motralec**

4 rue Lavoisier . ZA Lavoisier . 95223 HERBLAY CEDEX

Tel. : 01.39.97.65.10 / Fax. : 01.39.97.68.48

Demande de prix / e-mail : [service-commercial@motralec.com](mailto:service-commercial@motralec.com)

[www.motralec.com](http://www.motralec.com)