



SLM-AV
Sealless Magnet Drive Pump
ANSI/ASME B73.3M-1997



SLM-AV

Klaus Union introduces the new SLM-AV centrifugal magnet drive pump.

Klaus Union has more than 50 years experience in development, construction, production and application of magnet drive pumps. Our considerable experience in the chemical industry handling aggressive, toxic and explosive fluids under severe environmental and safety conditions has taught us that maximum flexibility is of prime importance. This includes customer requirements of optimum interchangeability of parts and accessories with short delivery times.

Satisfying these requirements resulted in a new, innovative approach to sealless technology.

The SLM-AV is a completely new ANSI-dimensional pump that is more than just another modification to a well established range of centrifugal pumps. It is manufactured to the highest standards and designed to offer the best and most economic solution to various pumping requirements.

The SLM-AV uses the *sealex*[®] magnet drive system, eliminating the need for a mechanical seal, since the motor torque is transmitted through the hermetically sealed chamber without mechanical contact.

The "V" of the SLM-AV means "variable." Fewer parts and increased interchangeability, result in greater flexibility and availability for all design variations and accessories.

The new SLM-AV allows optional variations within standard designs. Customer's individual demands can be realized quicker with reduced inventory requirements.

The modular concept makes everything possible

The modular approach provides the flexibility to construct a pump meeting the customer's special requirements – with an emphasis on price, delivery and interchangeability.

Technical Data

- Flow rates up to 775 GPM
- Total delivery heads up to 450 feet
- Temperature rating from -184°F (-120°C) to +572°F (+300°C)
- Flange connections per ANSI B16.5 Class 150 and Class 300

Pumping

acids
lyes
hydrocarbons
heat transfer liquids
liquid gases
aggressive, explosive, toxic liquids

Applications

Refineries
Chemical/petrochemical industries
Environmental control
Personnel safety
Refrigeration and heat engineering
Liquid gas plants
Galvanic engineering
Power stations
Tank installations
Pharmaceutical industries
Fibers industries

Construction

- horizontal centrifugal pump
- modular concept design
- separation of liquid chamber/ atmosphere by means of an isolation shell

- permanent magnet drive system, no mechanical seal
- synchronous drive transmitted by inner and outer magnet systems
- internal bearings made of pure sintered silicon carbide, alpha grade, liquid lubricated, for absorption of radial and axial loads
- bearings of outer magnet carrier: deep groove ball bearings

Materials

Standard Construction

pump casing:	316 SS
impeller:	316 SS
isolation shell:	316 Ti/Hastelloy C4
inner magnet carrier:	316 Ti/Hastelloy C4
internal bearings:	Alpha Grade, Silicon Carbide
bearing frame assembly:	Cast Steel/Nodular Cast Iron
magnets:	Rare Earth Samarium Cobalt

Special Alloy

Hastelloy B 1 (B)
Hastelloy C 1 (C)
Titanium

Special constructions and materials available.

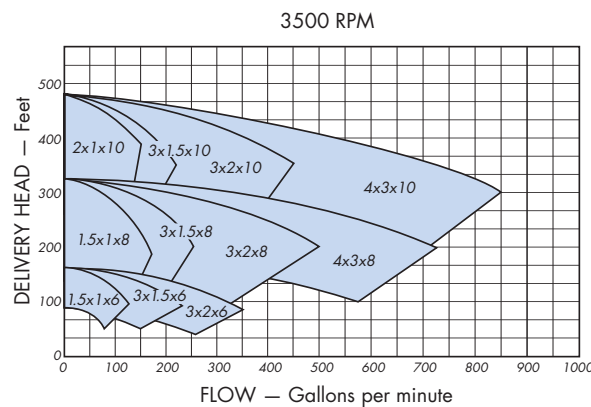
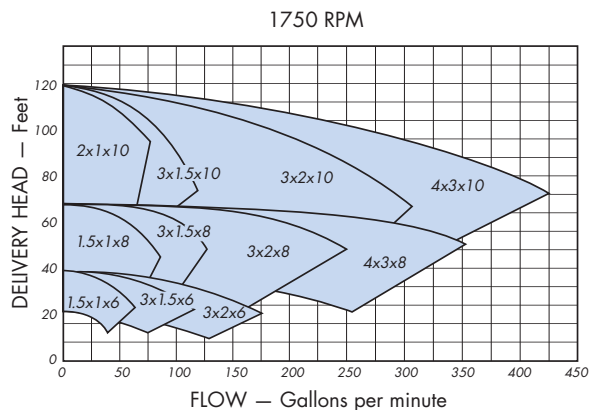

Lantern Heating

External heating is provided by the integral jacket with direct heat transfer to the isolation shell.

Flushing System

Sufficient pressure is maintained with an internal recirculation which safely controls liquids being processed close to their boiling point. Flush flow is taken from an area with reduced solids and is separated into two distinct flow paths. One flow path dissipates the frictional heat generated by the journal bearing. The second flow path dissipates the heat generated by eddy current losses in the isolation shell. This flushing system provides an almost constant flush flow rate and pressure.

Isolation Shell

Self-venting and fully drainable.

Balanced Thrust Load

Axial thrust loads are reduced throughout the entire operating range of the pump.

Journal Bearing

Wear resistant double bearing is made of silicon carbide. Counter centered combinations ensure the universal use with different temperatures.

Rub Rings

Internal and external mechanical rub rings protect isolation shell.

Magnet Drive

High efficiency magnet drive system incorporating samarium cobalt rare earth magnets.

Secondary Sealing

In case of internal leakage, the seal temporarily prevents the pressurized process fluid from entering the atmosphere.

Thermal Barrier

Protects the ball bearings from high process fluid temperatures. It works like an air cooler providing a large surface area for the dissipation of heat by convection. The thermal barrier permits the use of close coupled pumps in high operating temperatures.

Drive Frame

Oil lubricated design incorporates a large oil reservoir. The spacing and size of the deep groove ball bearings provide substantial support for the outer magnet carrier. Inboard and outboard lip seals prevent debris from entering oil sump. Ball bearing replacement can be achieved without breaking hermetic seal of the process fluid.

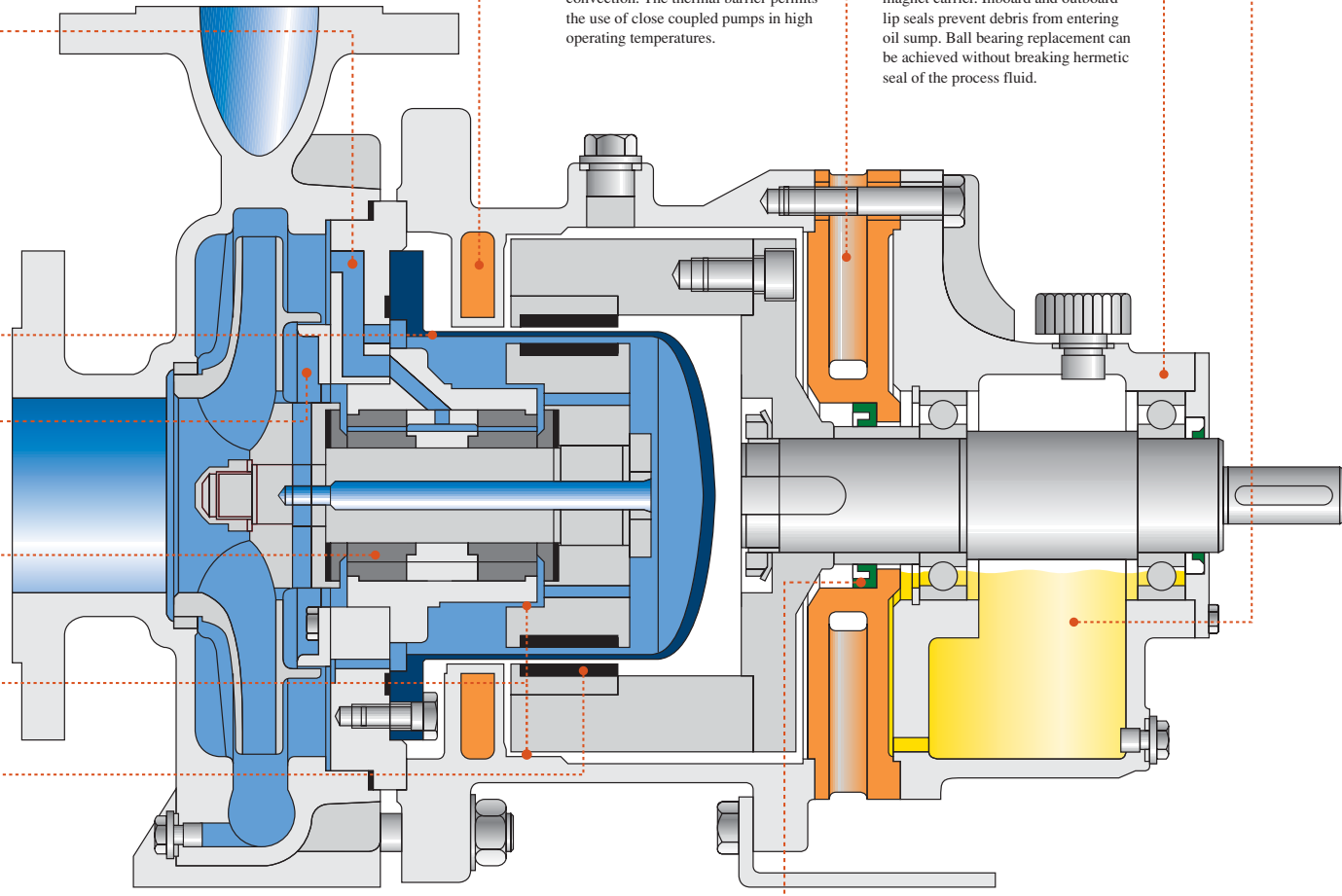

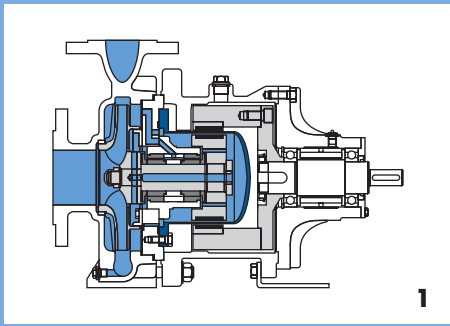

1

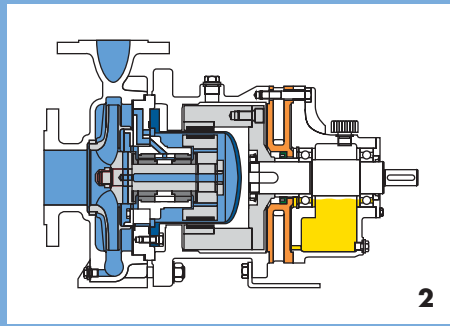

2

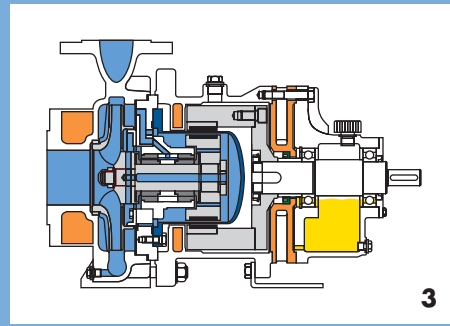

3

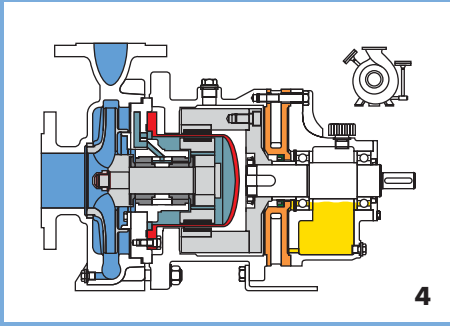

4

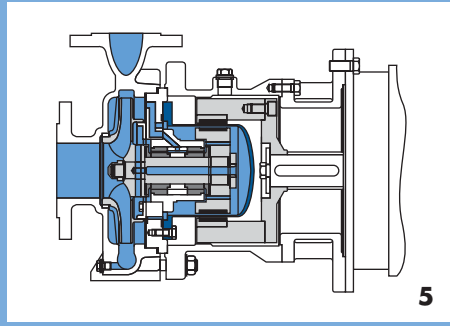

5

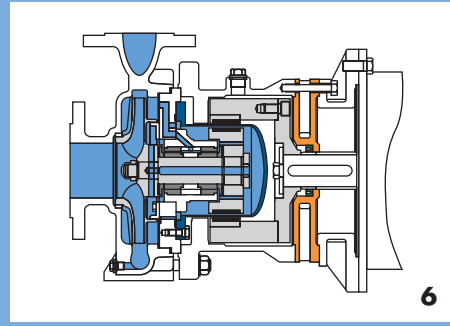

6

Sample variations:

- 1. SLM-AVN:** Basic design • grease lubrication • -184°F (-120°C) to +482°F (+250°C)
- 2. SLM-AVO:** Basic design • oil lubrication • thermal barrier • secondary sealing • -184°F (-120°C) to +572°F (+300°C)
- 3. SLM-AVO-H1/2:** Oil lubrication • thermal barrier • secondary sealing • heated casing • heated bearing lantern • -184°F (-120°C) to +572°F (+300°C)
- 4. SLM-AVO-OT:** Dry running capability • oil lubrication • thermal barrier • secondary sealing • -4°F (-20°C) to +248°F (+120°C)
- 5. SLM-AVB:** Basic design • close coupled • -184°F (-120°C) to +320°F (+160°C)
- 6. SLM-AVB:** Close coupled • thermal barrier • secondary sealing • -184°F (-120°C) to +482°F (+250°C)
- 7. SLM-GVO:** Oil lubrication • 1-8 stages • thermal barrier • secondary sealing • -184°F (-120°C) to +482°F (+250°C)
- 8. SLM-SVO:** Side channel • oil lubrication • 1-8 stages • fully heated • thermal barrier • secondary sealing • -184°F (-120°C) to +482°F (+250°C)

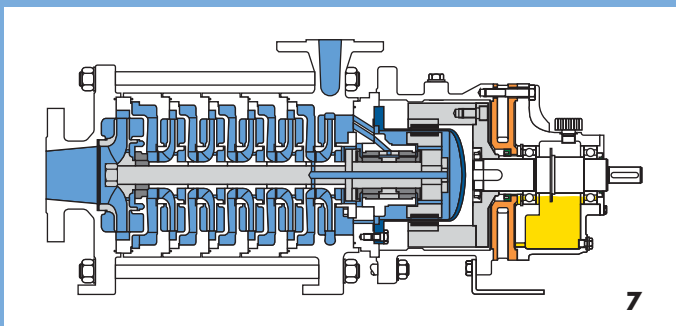
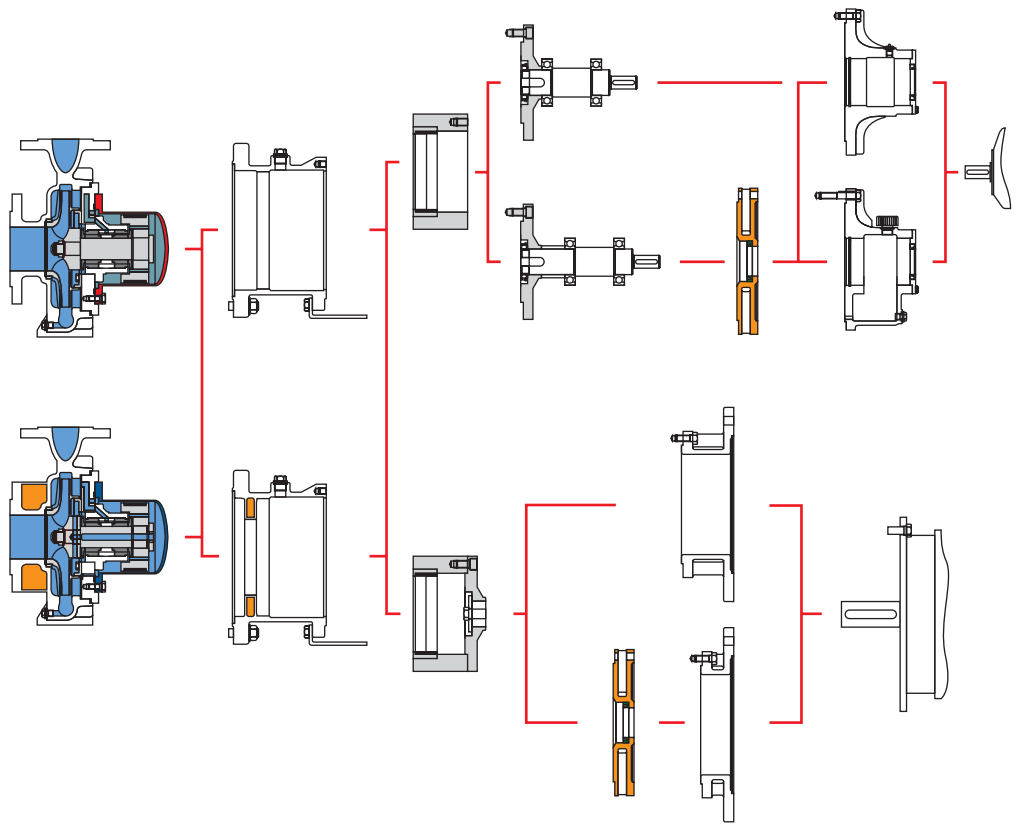

7

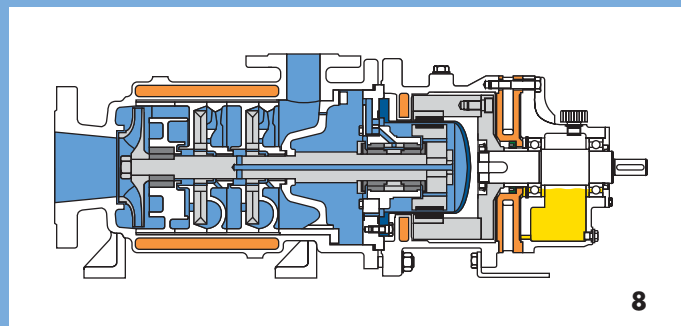

8

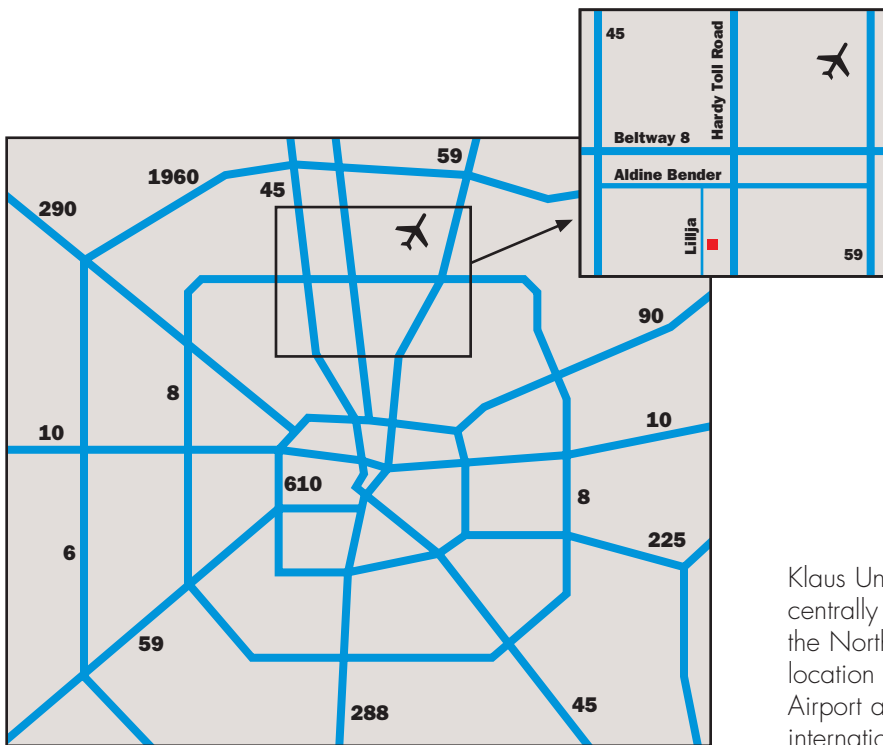

Klaus Union, Inc. is conveniently situated centrally in the United States to service the North American markets. The strategic location near Houston Intercontinental Airport allows easy access for domestic and international shipping and transportation.



motralec . 4 rue Lavoisier . ZA Lavoisier . 95223 HERBLAY CEDEX. Tel. : 01.39.97.65.10 / Fax. : 01.39.97.68.48

Demande de prix / e-mail : service-commercial@motralec.com . Site Internet : www.motralec.com