

# VYDAS

## INTERNATIONAL MARKETING

*Specialist Sensors & Instruments for Industry*

## NEW DIGITAL PUMP LOAD CONTROL



- ◆ Power sensor monitors true motor power
- ◆ Waterproof & rugged, large red LED display
- ◆ Compact enclosure with flexible fittings
- ◆ Easy front panel keypad set up
- ◆ Low and high setpoint trips with relay outputs
- ◆ Adjustable trip timers to prevent nuisance trips
- ◆ Adjustable digital on-delay timer
- ◆ 4-20mA output for computer, logger or recorder
- ◆ Detect dry running, loss of prime or cavitation
- ◆ Detect overloads or underloads
- ◆ Detect bad bearings or jammed impellers
- ◆ Extremely sensitive even at low loads

### DESCRIPTION

The compact PMP-25 Digital Load Control provides an efficient low cost solution to the prevention of damage to pumps caused by overload, jamming, loss of load or pump dry running. The rugged polycarbonate sealed enclosure may be mounted in many configurations including door, wall or cabinet. The unit is easy to install and displays true power on a large easy to read bright red digital LED display. Both high and low power trip relays with adjustable start up delay and individual trip timers are standard features. The low power trip, when used to detect cavitation or loss of prime, is up to ten times more sensitive that of conventional undercurrent relays. The high power trip is provided for the detection of problems such overloads, jammed impellers, bad bearings or blocked outlets. The PMP-25 will protect pumps of all types, including seal-less or magnetic drive, centrifugal, positive displacement, and screw pumps.

### Why Monitor Power Instead of Just Amps?

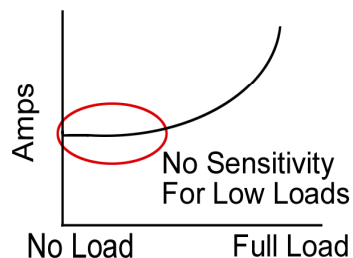
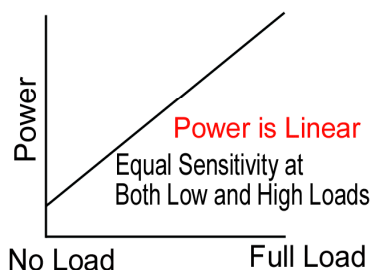

# What are you doing to protect your pumps?

Ideal for use with Magnetic Drive Pumps

- Detects Loss of Load  
Avoids Dry Running
- Detects Overloads  
Bad Bearings, Jam ups

Senses True Motor Power.  
10X more sensitive than just Amps.

## Monitoring Pump Horsepower Tells You What's Happening to the Fluid

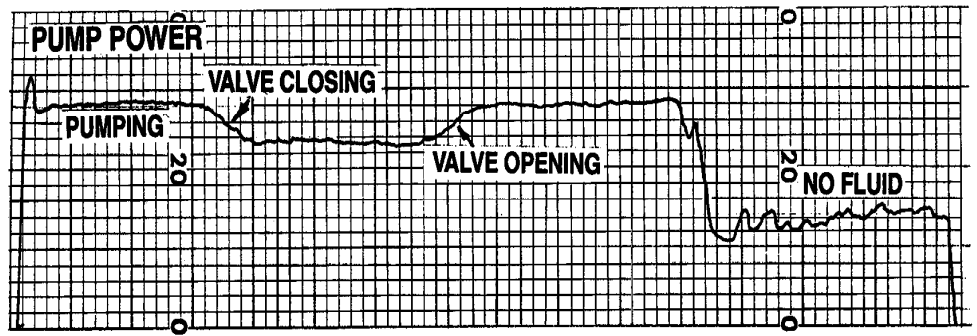

### SPECIFICATIONS

<b>Wiring</b>	Unpluggable Terminal Strips on Rear	<b>Timers</b>	Start up 0-999 sec. (16.7 min.) adjustable Low Trip Delay 0-999 sec. (16.7 min.) adjustable High Trip Delay 0-999 sec. (16.7 min.) adjustable
<b>Load Display</b>	0.4" LED 3 Digit % of Full Load Horse Power or Kilowatts	<b>Relay Outputs</b>	(2) Form C 3 AMP @ 300 VAC or 1/8 HP @ 240 VAC Latch when tripped
<b>Capacity</b>	To 50 HP directly through Toroid To 500 HP with external Current Transformed & Toroid Change capacity with dip switches	<b>Analogue Output</b>	4-20mA; powered by the Control, 500 OHM maximum load impedance
<b>Response Time</b>	500 Milliseconds	<b>Reset</b>	Local -Button on control Remote - with Low Current Switch or Relay Automatic - with jumper (link) Latching Relays- chose when to reset
<b>Temperature</b>	0 C - 55 C		

### CONNECTIONS

PMP-25 HOOK-UP

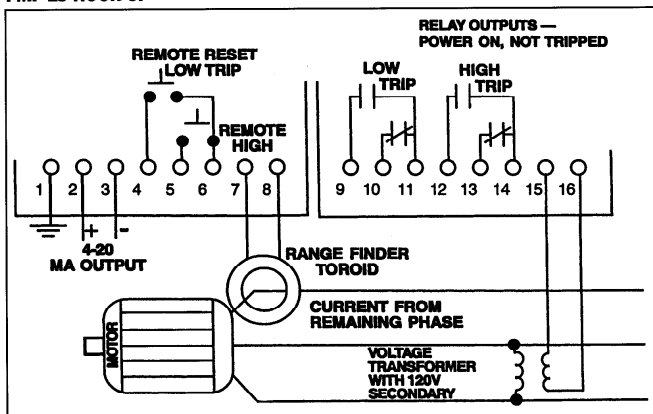

### DIMENSIONS

#### Enclosure

Glassfilled Polycarbonate NEMA 4, 4X  
(3 1/4" x 6 1/4" x 2")  
(83mm x 160mm x 54mm)

#### Mounting Options

On door, in cabinet  
Panel mount with Bezel Kit  
On wall with outlet Box Kit

#### UNIQUE RANGE FINDER TOROID

- One Sensor For Capacities From Fractional up to 50 HP
- Use Optional Current Transformers for Big Motors

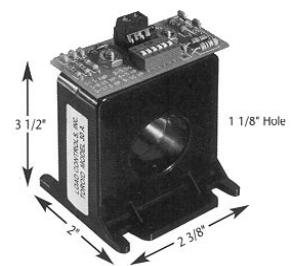

Call **01428 751822**

For Further Information

### MANUFACTURER

**LOAD CONTROLS INCORPORATED**



# PMP-25 PUMP LOAD CONTROL INSTALLATION, SET UP AND ADJUSTMENT



The Model PMP-25 monitors the true power going to a motor. By sensing power (volts x amps x power factor) rather than just amps, there is much greater sensitivity. For loss of load detection, this means a 10X improvement in performance.

## MOUNTING

Wiring is done to un-pluggable terminal strips on the rear of the unit.

Three ways to mount:

- On door or raceway – use cutout template
- Panel Mount – use template + optional Bezel Kit
- On wall – on standard outdoor junction box + optional Outlet Box Adapter

## VOLTAGE

120 Volts AC is taken from two of the phases. If the motor starter already has a 120 Volt control transformer with 10VA of free capacity, it can be used. Otherwise, install a separate transformer. It is okay if the secondary is grounded.

**BE SURE TO NOTE WHICH TWO PHASES SUPPLY THE TRANSFORMER.**

In 120/208V three phase system, the 120V MUST come from a transformer connected to two of the phases. The 120V phase to ground voltage cannot be used.

## CURRENT

The current signal is taken from the REMAINING phase. This current sample passes through the Range Finder Toroid.

It is VERY IMPORTANT that the current signal comes from the phase that IS NOT supplying the 120V control transformer. Be extra careful when the machine has reversing starters or multi-speed windings. If a wrong phase is used the control will either:

- Work backwards
- Have reduced sensitivity

If you are using a variable frequency drive, use a different control. Call Vydas International for help.



**Vydas International Marketing**  
Swan House Passfield Business Centre  
Lynchborough Road Passfield  
Hampshire GU30 7SB United Kingdom  
Tel:44(0)1428 751822 Fax:44(0)1428 751833  
Email:[info@vydas.co.uk](mailto:info@vydas.co.uk) Web: [www.vydas.co.uk](http://www.vydas.co.uk)

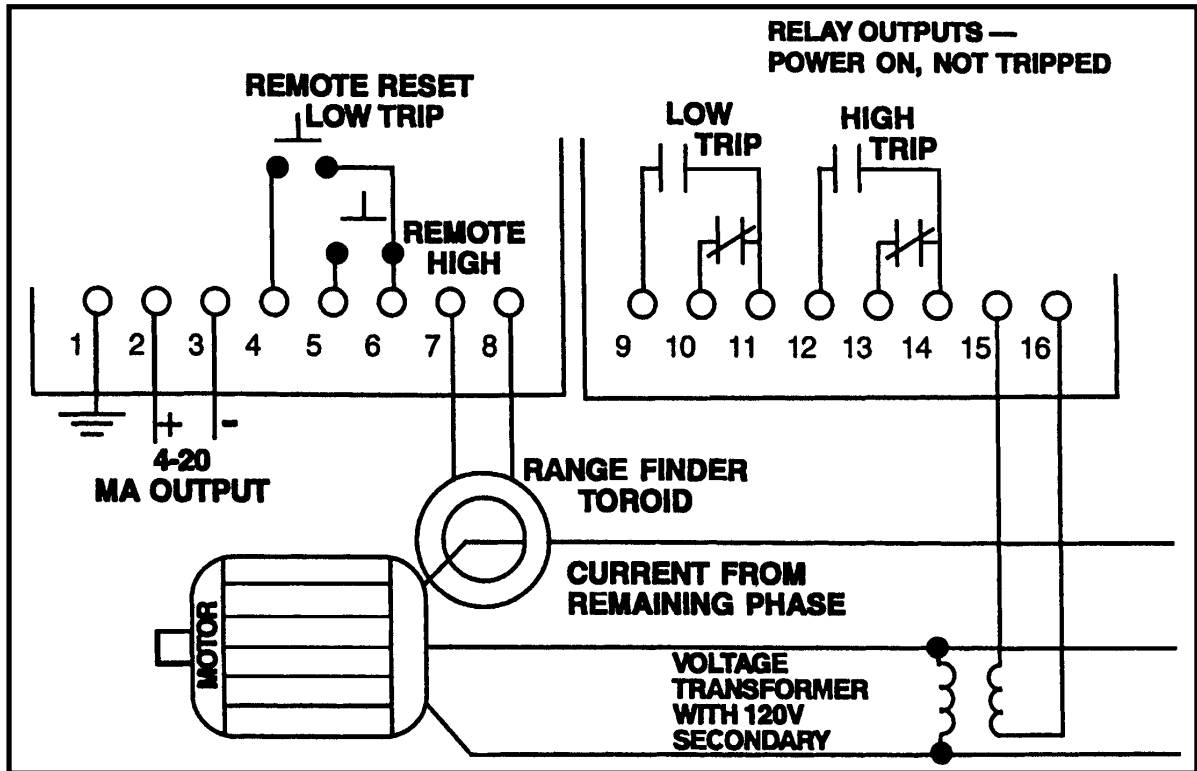

**FULL SCALE CAPACITY AT 460 VOLTS**

The Range Finder Toroid has 6 motor size choices. Select one that is equal or larger than your motor. This will leave some headroom.

- For motors less than 5HP (460 VOLT), take extra turns.
- For motors greater than 50HP use Range Finder Toroid + Current Transformer.

MOTOR SIZE	FULL SCALE CAPACITY	%FULL LOAD	RANGE FINDER SWITCH	TURNS	CURRENT TRANSFORMER
1 HP	1.25 HP	123	2 ON	4	
1-1/2	1.65	109	2 ON	3	
2	2.70	134	2 ON	2	
3	3.80	128	3 ON	2	
5	5.50	110	2 ON	1	
7-1/2	8.25	110	3 ON	1	
10	11.0	110	4 ON	1	
15	27.5	183	5 ON	1	
20	27.5	137	5 ON	1	
25	27.5	110	5 ON	1	
30	55.0	183	6 ON	1	
40	55.0	138	6 ON	1	
50	55.0	110	6 ON	1	
60	84.0	140	1 ON	1	100:5
75	84.0	112	1 ON	1	100:5
100	130	130	1 ON	1	150:5
125	130	104	1 ON	1	150:5
150	173	115	1 ON	1	200:5
200	216	108	1 ON	1	250:5
250	260	104	1 ON	1	300:5
300	346	115	1 ON	1	400:5

**MULTIPLIERS**

For Nominal Voltages  
Other Than 460 Volts  
Multiply 460 V full scale by:  
208V = .45  
230V = .5  
380V = .83  
415V = .9  
575V = 1.25  
For Kilowatts  
Multiply Full Scale HP x .746

## RANGE FINDER TOROID

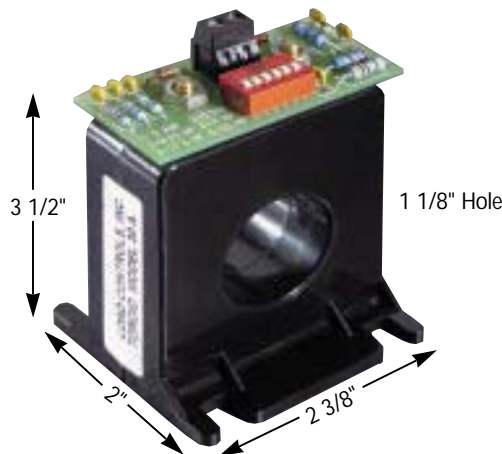

FOR MOTORS LESS THAN 5 HP  
Take more "turns" of the leg through the Toroid. Each time the wire passes through the Toroid is a "turn".

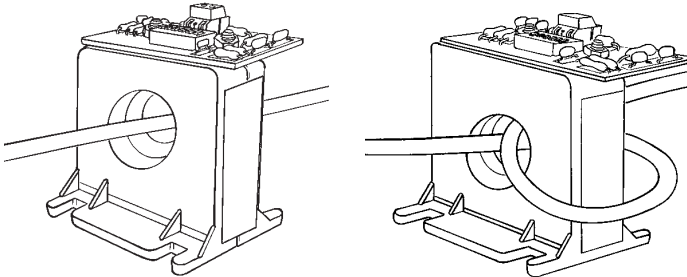

*This is one turn.*

*This is two turns.*

FOR MOTORS GREATER THAN 50 HP  
A Current Transformer is used to reduce the primary current. The 5 Amp secondary passes through the Toroid.

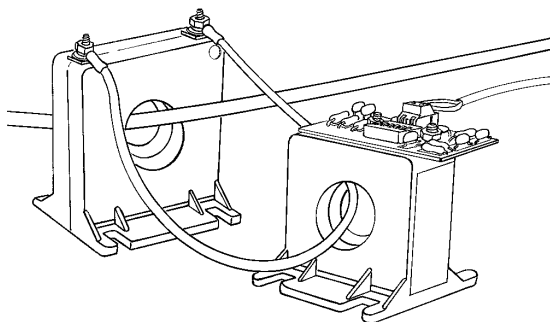

*Pass secondary Of CT through toroid.*

## CAUTION

When current is flowing through the primary of the external current transformer, always have a wire between the 2 brass Terminals on the CT.

If they are left open, dangerous and destructive voltages can develop.

## HOOKING UP THE RESET

Control can be reset 3 ways:

- Manually with the Reset button on the control.
- Remotely with a remotely located reset button or relay.
- Automatic with a jumper.

### Remote Reset-

Momentarily connect Terminal 4 to Terminal 6 for low  
Momentarily connect Terminal 5 to Terminal 6 for high

### Automatic Reset-

Jumper Terminal 4 or 5 to Terminal 6

The terminals for Reset generate a small amount of current (8-12 milliamps). To reset, you just need to connect the terminal to the circuit common (Terminal 6).

The switches or relays that you use must be suitable for low current. (Gold flashed contacts, Reed Relays, Mercury Switches).

## 4-20 MILLIAMPER ANALOG OUTPUT

The Analog Output is directly proportional to Full Scale capacity. It is always active. 500 ohm maximum connected impedance.

Terminal 2	4-20mA	Positive
Terminal 3	4-20mA	Negative

Use twisted pair or in noisy environments, use shielded cable. Ground shield at other end.

Use the Full Scale capacity from the chart to scale external meter, chart recorders or computers.





THE PMP-25 POWERS THE 4-20MA SIGNAL.  
DON'T USE AN EXTERNAL DC POWER SUPPLY.

## SPECIFICATIONS PMP-25



ENCLOSURE Glass-filled Polycarbonate NEMA 4, 4X - STYLE (3 1/4" x 6 1/4" x 2") (83 mm x 160 mm x 54 mm)	ANALOG OUTPUT 4-20mA; powered by the PMP-25 500 OHM maximum connected impedance
CAPACITY To 50 horsepower directly through Toroid To 500 horsepower with external Current Transformer & Toroid	RESPONSE TIME 500 Milliseconds
DIGITAL LOAD DISPLAY .4" LED 3 Digit	TEMPERATURE 0 C - 55 C
RELAY OUTPUTS (2) Form C 3 AMP @ 300 VAC or 1/8 HP @ 240 VAC Latch when tripped	TIMERS Start-up - 0-999 seconds (16.7 minutes) adjustable Low Trip Delay - 0-999 seconds (16.7 minutes) adjustable High Trip Delay - 0-999 seconds (16.7 minutes) adjustable
	Y2K COMPLIANT

## FRONT PANEL SET-UP

### TIPS:

- None of the settings will be changed until you hold down  and the fast blinking stops.
- 5 seconds after you have pressed a button, the control will return to normal operation.
- If you hold down the   digits will continue to change.
- You only need to do  when you install the PMP-25 (or if you change the hook-up).

## TO SET FULL SCALE

- After hook-up, find your HP, KW or % from the chart.
- Decide if you want to display HP, % or KW.
- The  cycles through the choices shown below and blinks slowly for each choice. Each press of  moves you to the next choice.

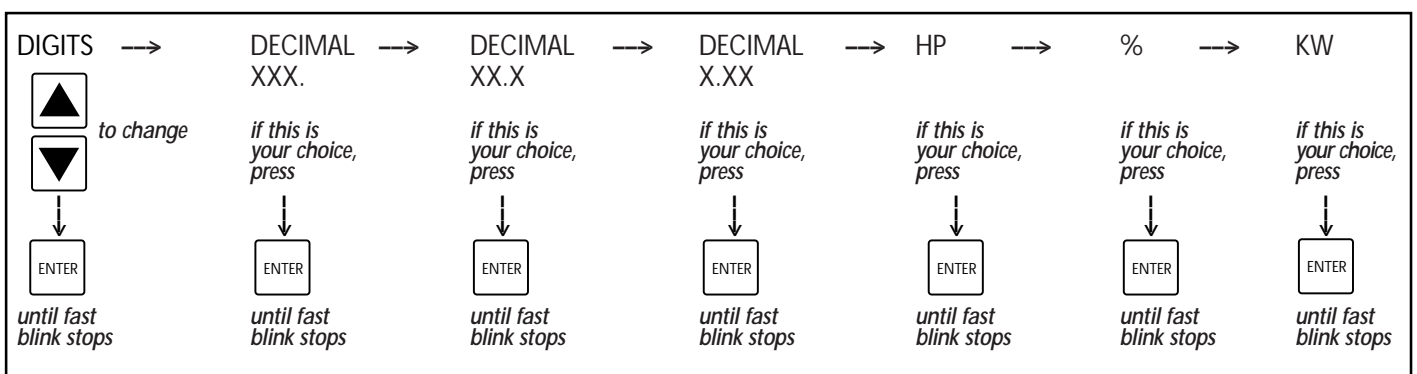

## ADJUSTMENTS

**SET POINT - HIGH:** The HIGH relay will switch when the load is above the HIGH.

**SET POINT - LOW:** The LOW relay will switch when the load is below the LOW.

### Start Up Timer

The Start Up Timer bypasses the Control during motor start up to avoid false trips because of current inrush. For convenience, the TIMING BEGINS WHEN THE MOTOR STARTS. The Start Up LED stays lit until the Start Up period is over.

The start up time should be:

- Long enough so that the load has stabilized.

### Delay Timers

To avoid nuisance trips from short overloads, Delay Timers bypass the Control for the selected time. The relays won't trip until the time is exceeded. If the trip condition goes away before the time is up, the timer resets to zero.

- Start with minimum Delay. If you are getting trips where you don't want them, increase the Delay Time.

## TO VIEW AND CHANGE THE SET POINTS AND DELAY TIMES

 cycles through the choices. The LED for each choice will turn ON.

To change a setting, use



Press ENTER until quick blinking stops to store your new choice.

After 5 seconds if you haven't pressed any buttons, control will return to normal operation.

## ADJUSTMENT TIPS FOR CENTRIFUGAL PUMPS

From Pump Curves

Use the recommended minimum and maximum flows and horsepower for your initial set points.

–OR–

### Actual Operation

**Low Trip -** Run the pump with the OUTLET valves closed.

This is the minimum flow. Set the low trip about here.

**High Trip -** Run the pump with all valves wide open.

This is the maximum flow. Set the high trip about here.

- Make adjustments if you get nuisance trips

