



# Operation Manual

## CDS - System

**motralec**

4 rue Lavoisier . ZA Lavoisier . 95223 HERBLAY CEDEX  
Tel. : 01.39.97.65.10 / Fax. : 01.39.97.68.48  
Demande de prix / e-mail : [service-commercial@motralec.com](mailto:service-commercial@motralec.com)  
[www.motralec.com](http://www.motralec.com)

**01/2006**

BAE-50000-09-Deckblatt-01.doc

## CDS – Monitoring of Isolation Shell:

The purpose of the CDS system for monitoring the isolation shell is to define and to give a fault signal in case of failure of the double isolation shell. The monitoring system responds to pressure changes in the space between the inner and the outer isolation shell. After installation of the CDS system on the isolation shell, vacuum will be generated in the space between the two shells. The fault signal is effected by two intrinsically safe proximity switches (1 and 2) which are triggered in case of a change of pressure by a control lug (4) actuated by a pressure diaphragm (3).

The signal processing is effected by a dual-port isolating switch amplifier type WE 77/Ex 2 with floating output. The electric circuit of this instrument is intrinsically safe to (EEx ia) II C.

Together with the double isolation shell, the isolation shell monitoring forms an absolutely leak-free and vacuum-sealed system with all pressurized connections being welded.

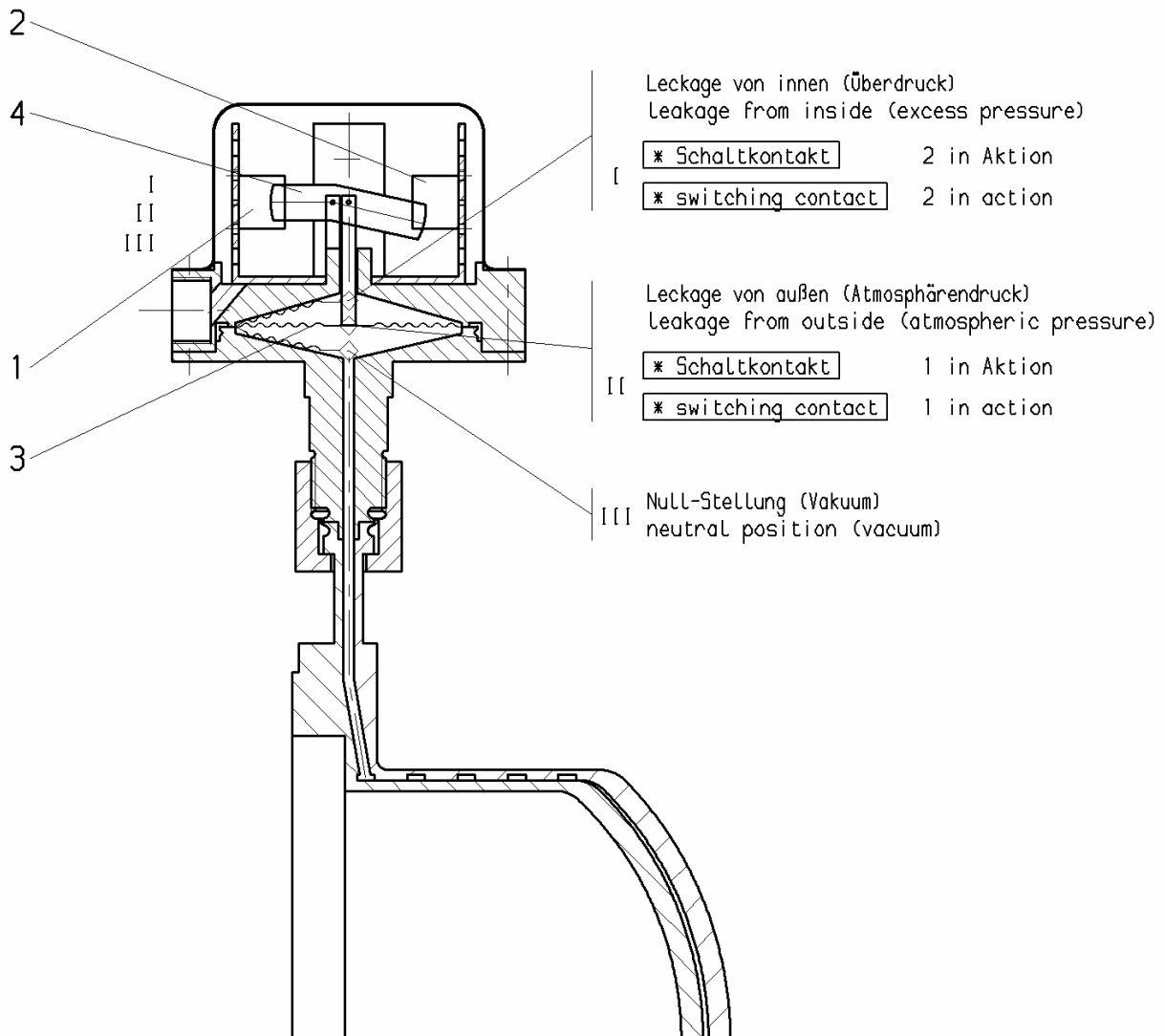

**Technical Data:**

**Allowable pressure range** : between vacuum up to an excess pressure of 25 bar

**Proximity switches:**

Electrical design : direct voltage, two-wire to DIN 10234 (Namur)

Protection mode : intrinsically safe to ( EEx ia ) IIC

Characteristic data : switching point at 60% depth of immersion  
: reproducibility  $R < 0.01$  mm  
: differential travel  $H < 0.2$  mm  
: operating voltage UB 5 - 25 V  
: residual ripple  $< 5$  %  
: operating frequency 2 kHz  
: allowable operating temperature  $-25^{\circ}\text{C}$  to  $+100^{\circ}\text{C}$

Electrical data : nominal voltage 8 V DC / Ri abt. 1 kOHM  
: self-inductance 0.00042 H  
: power input: sensing area free  $> 3$  mA

**Isolating switch amplifier:**

Supply voltage : 220 V / 45 - 65 Hz

Wattage : 3.5 W

Inputs (intrinsically safe) : no-load voltage  $U_{A0}$  abt. 8 V DC  
: short-circuit current  $I_{AK}$  abt. 8 mA  
: open-circuit monitoring  $J < 150$  uA

Data to CE-Certificate : Ex - 79/2043X  
: max. voltage  $U_0 = 13.5$  V DC  
: max. current  $J_K = 31$  mA  
: power  $P_{max} = 125$  mW  
: type of protection (EExia)  
: explosion group IIC  
: max. outer capacitance 230 nF  
: outer inductance 3 mH

Outputs (non-intrinsically safe) : 2 floating outputs  
: 2 X 1 changeover contacts

Contact load : AC 250 V/4 A/500 VA  
: DC 220 V/0.1 A  
: DC 60 V/0.6 A  
: DC 24 V/4 A

induktive Näherungsinitiatoren  
inductive proximity switch

