



12L SERIES THREE SCREW PUMPS



motralec

4 rue Lavoisier . ZA Lavoisier . 95223 HERBLAY CEDEX

Tel. : 01.39.97.65.10 / Fax. : 01.39.97.68.48

Demande de prix / e-mail : service-commercial@motralec.com

www.motralec.com

The reliable pump people

ROTARY SCREW PUMPS

Performance Shown at 3000 PSID (207 BAR), 200 SSU (43 CST)

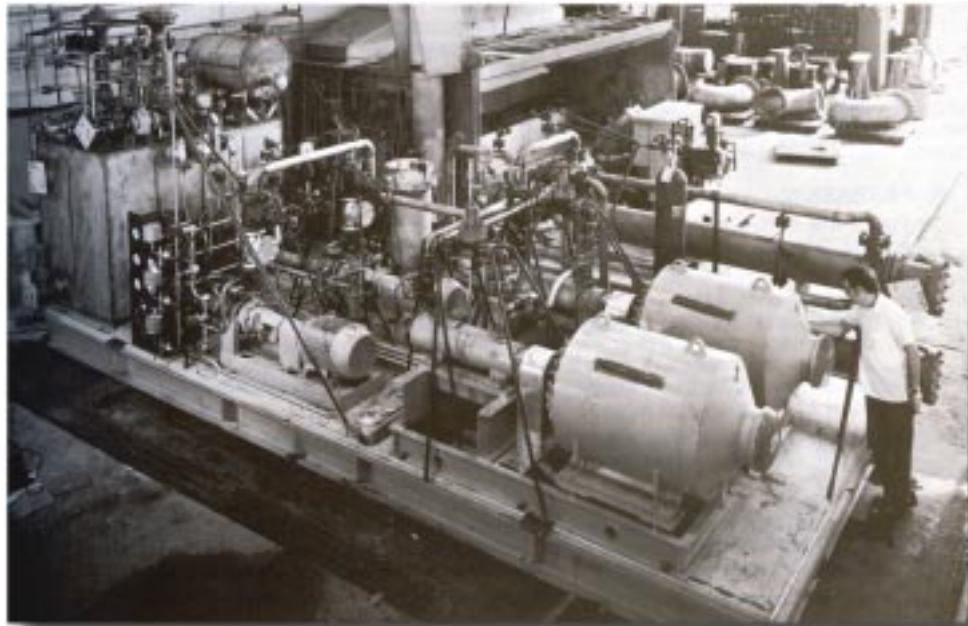
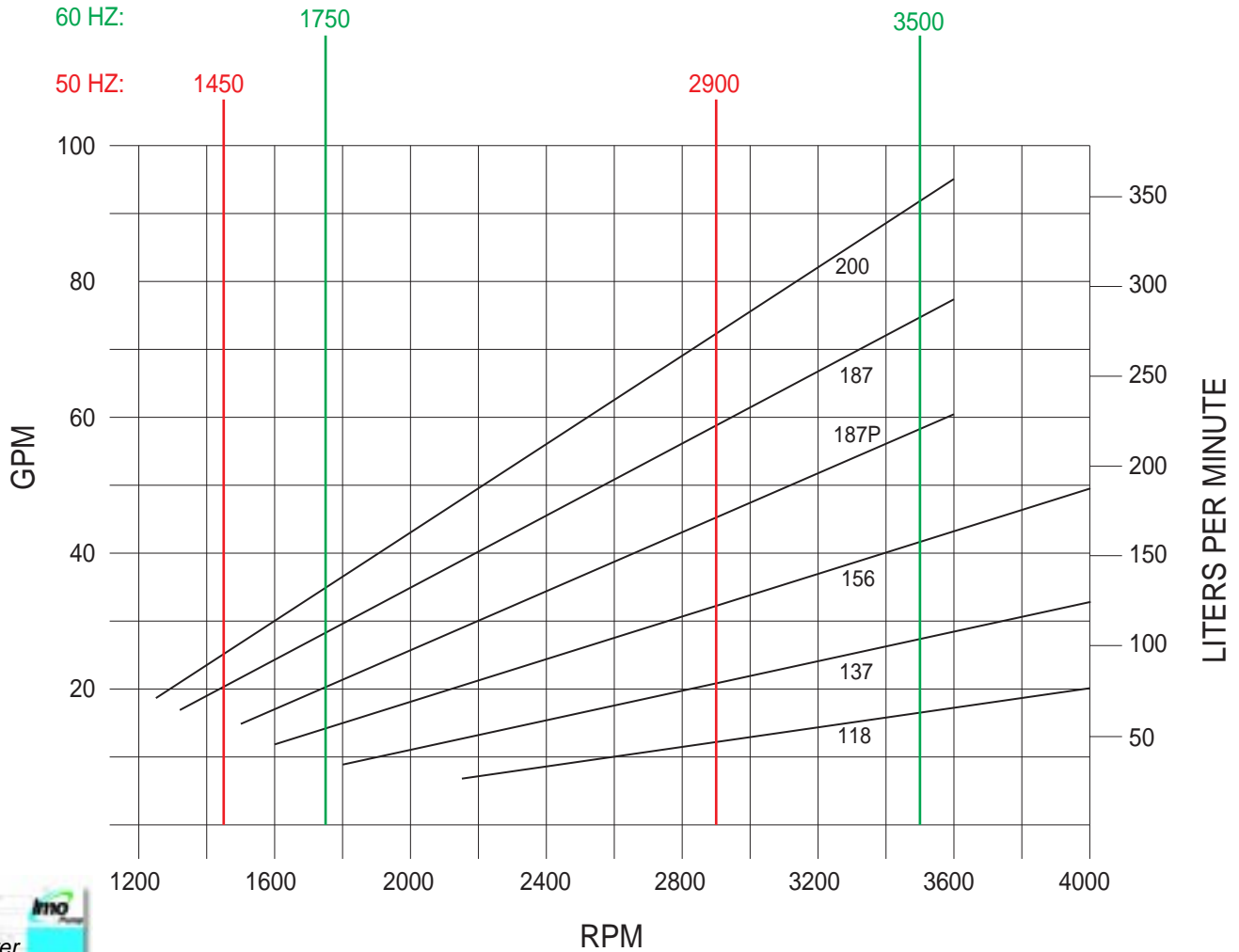

Two 12L-187 pumps with 250 HP, 3500 RPM motors supplying 4375 psig seal oil to a North Sea platform gas reinjection compressor.

Imo Series 12L Pump

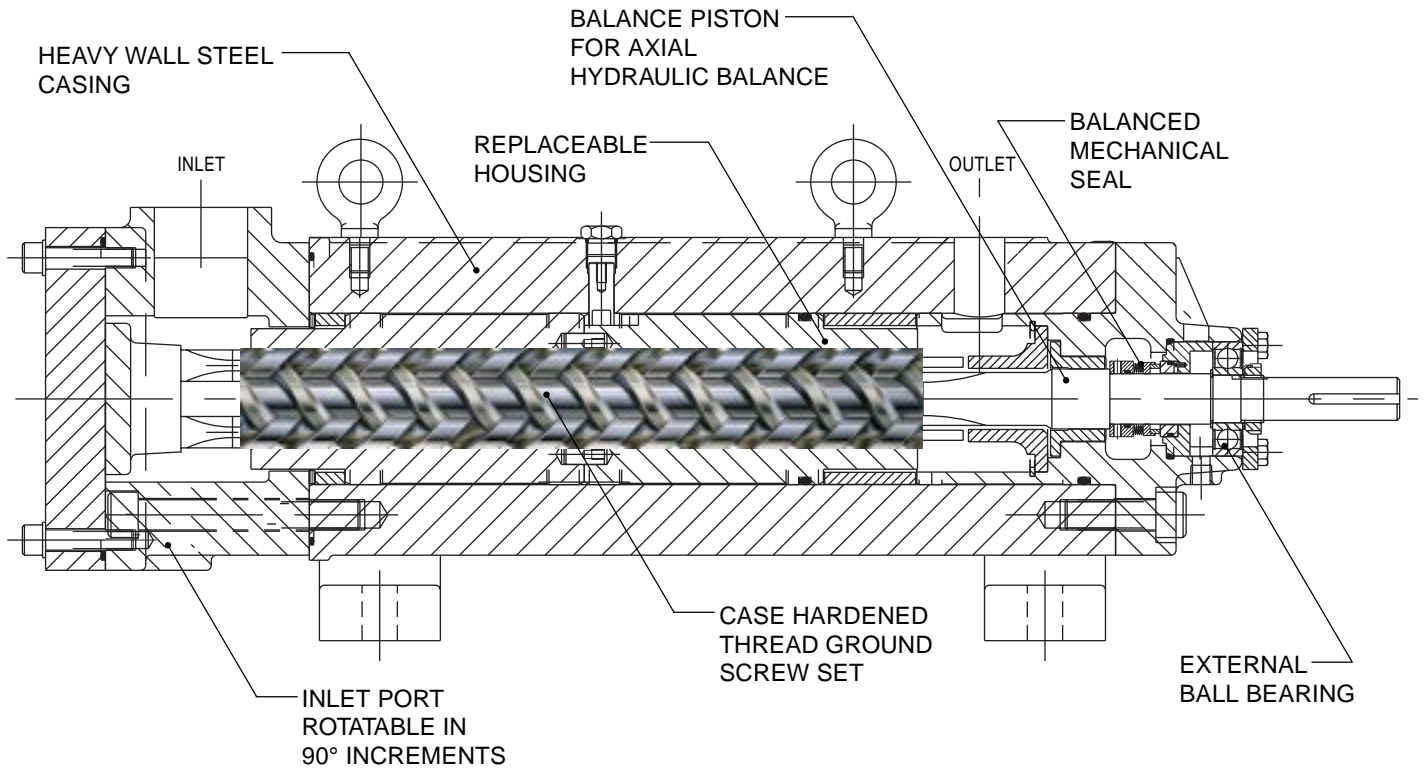

Model No. Code Example E 12L Y I F S - 187P

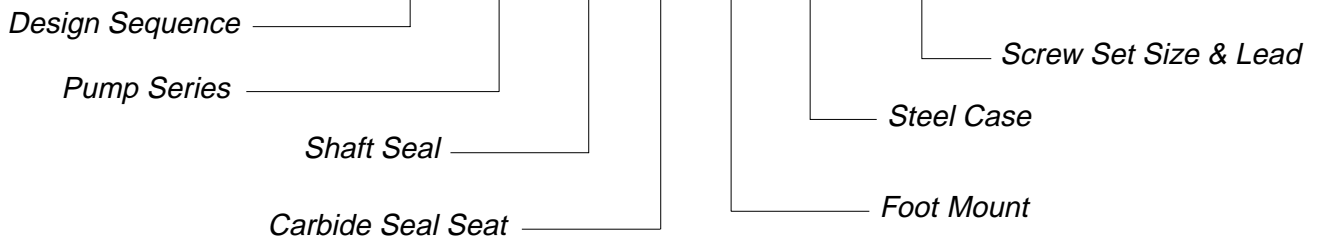

Specifications

Casing	Cast steel.
Rotor Housing	Babbitt plated perlitic cast iron.
Power Rotor	Alloy steel, nitride hardened and thread ground.
Idler Rotors	Perlitic ductile iron, hardened and thread ground.
Gaskets	Fluoroelastomer.
Seal & Bearing	Balanced metal bellows mechanical seal with carbon on carbide faces and external, permanently grease packed deep groove ball bearing.
Accessories	Completely mounted, built to order pump/driver assemblies are available with baseplates, ANSI RF spool pieces, etc.
Outlet Pressure	4500 PSIG (310 BAR) maximum, 4000 PSIG (276 BAR) maximum for size 118. Minimum recommended differential pressure is 40 PSI (2.8 BAR).
Inlet Pressure	200 PSIG (13.8 BAR) maximum.
Viscosity	45 to 3000 SSU (6 to 650 CST).
Temperature	0 to 250°F (-18 to 121°C).
Drive	Direct only.
Rotation	Clockwise facing pump shaft.
Mounting	May be foot mounted in any orientation.
Filtration	Inlet strainers are required to keep contaminants and abrasives out of the pump. They must be selected in consultation with the strainer vendor to prevent pump starvation. Normally, 25 micron or finer is recommended.
Maximum Speed*	4400 RPM maximum for sizes 118 thru 156. 3600 RPM maximum for sizes 187 and 200.

* Assumes minimum inlet pressure requirements are met.

10-100 GPM (38-378 L/M) Pressure to 4500 PSIG (310 BAR)

12L series pumps are designed for high pressure applications such as compressor gas sealing, hydrostatic bearings and fluid power services. Operating noise levels are typically below 75 dBA at full pressure and two pole motor speeds. The cast steel case and balanced shaft seal with carbon on carbide faces are intended to offer compliance with API requirements. Pump inlet port is rotatable in 90 degree increments to suit piping layouts. The pump includes mating carbon steel SAE 4-bolt, 6000 PSI rated socket weld flanges. Pump casing is hydrostatic tested to 7500 PSIG. 12L series pumps have become the world standard for gas sealing services on high pressure centrifugal compressors in process, refinery and offshore applications.

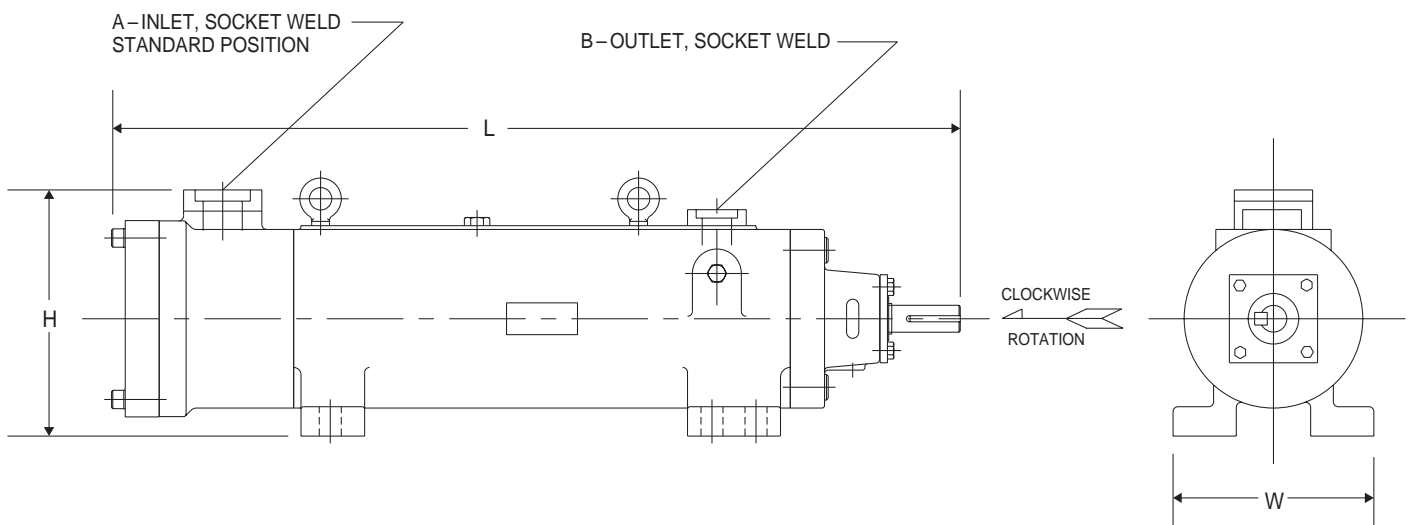

SIZE	A		B		H		L		W		WEIGHT	
	INCH	MM	INCH	MM	INCH	MM	INCH	MM	INCH	MM	LBS.	KG
118	1.50	38.1	1.00	25.4	5.75	147.0	26.75	680.0	8.50	216.0	230	105
137/156	1.50	38.1	1.25	31.8	6.00	153.0	33.75	858.0	11.50	293.0	360	164
187/200	2.00	50.8	1.50	38.1	7.00	178.0	42.75	1086.0	13.00	331.0	580	264



A Member of the
COLFAX PUMP GROUP

motralec

4 rue Lavoisier . ZA Lavoisier . 95223 HERBLAY CEDEX
Tel. : 01.39.97.65.10 / Fax. : 01.39.97.68.48
Demande de prix / e-mail : service-commercial@motralec.com
www.motralec.com



ALLWEILER



HOUTTUIN



IMO PUMP



WARREN



COLFAX PUMP GROUP



Quality Management System