

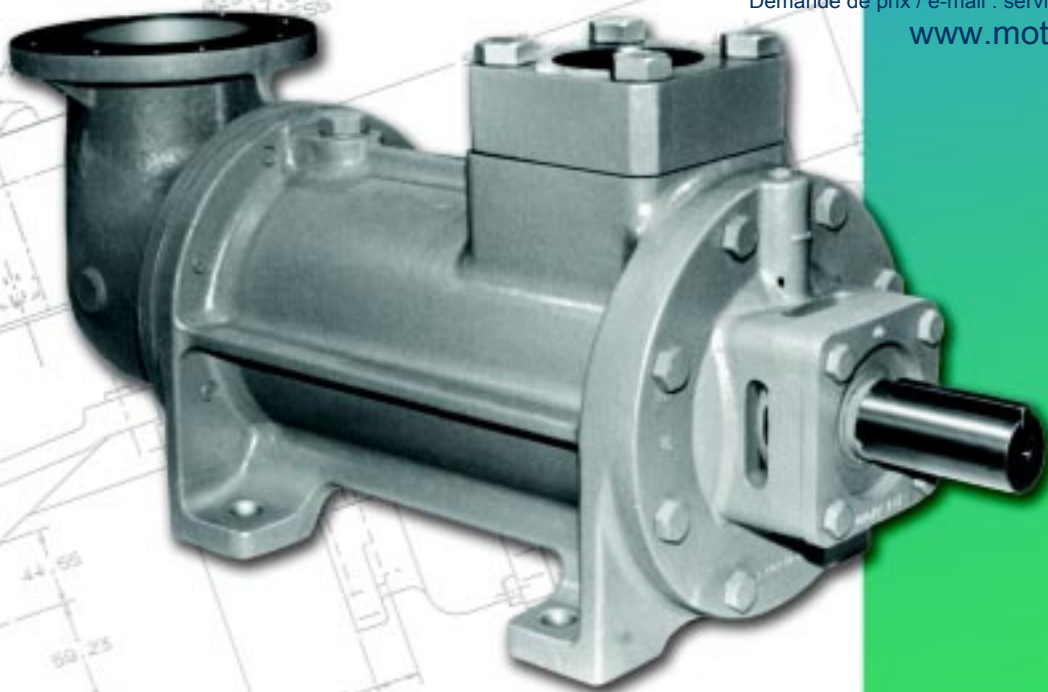

# 3D Series Three Screw Pumps



**motralec**

4 rue Lavoisier . ZA Lavoisier . 95223 HERBLAY CEDEX  
Tel. : 01.39.97.65.10 / Fax. : 01.39.97.68.48  
Demande de prix / e-mail : [service-commercial@motralec.com](mailto:service-commercial@motralec.com)  
[www.motralec.com](http://www.motralec.com)

*The reliable pump people*

# Performance Shown at 250 PSID (17 BAR), 200 SSU (43 CST)

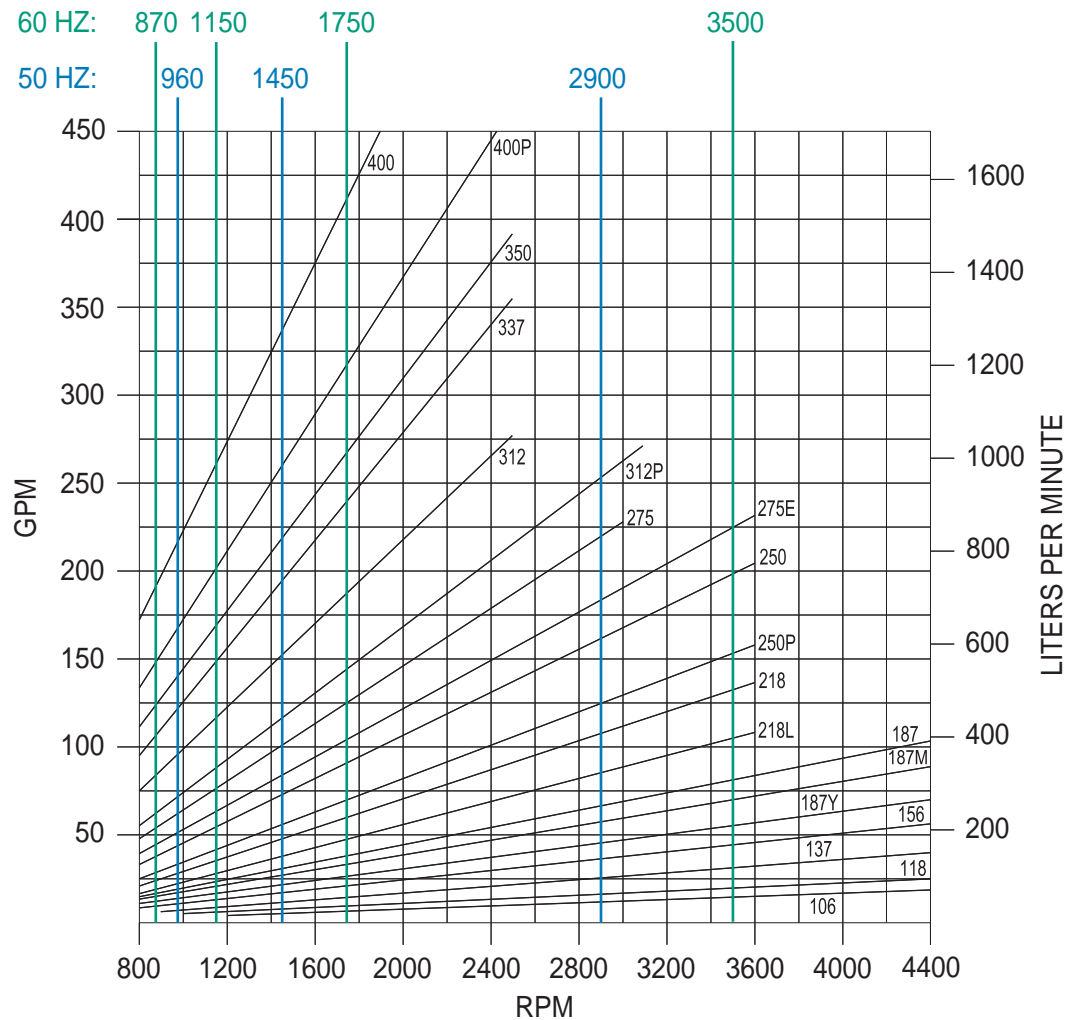

Vertical, magnetic drive 3D-250 pump on chemical service



Main and standby 3D-218 fuel pumps on common skid with inlet strainer, discharge relief valves and block valves.





# Specifications

## Casing

High tensile, close-grained cast iron. Cast steel available in sizes 156 and larger.

## Rotor Housings

Pearlitic gray iron.

## Power Rotor

Alloy steel, hardened and ground.

## Idler Rotors

Pearlitic gray iron, hardened and ground.

## Gaskets

Cellulose plant fiber.

## Shaft Seal & Bearing

Type B: Buna N bellows mechanical seal, Buna N o-rings and external, permanently grease-packed deep groove ball bearing, all sizes. Recommended for distillate, lube and hydraulic oils.

Type H: Positive drive mechanical seal, fluoroelastomer o-rings and external, permanently grease packed deep groove ball bearing, all sizes. Recommended for residual and crude oils and higher temperature liquids.

## Outlet Pressure

500 PSIG (34.5 BAR) maximum.

## Inlet Pressure

75 PSIG (5.2 BAR) maximum, sizes 106-187.

50 PSIG (3.4 BAR) maximum, sizes 218-up.

Designs available for inlet pressures to 300 psig with dimensions slightly different than standard. Consult your Imo Pump representative.

## Viscosity

Minimum 33 SSU (2.0 cSt).

Type B: 2500 SSU (540 cSt) maximum.

Type H: 15,000 SSU (3250 cSt) maximum.

## Temperature

Type B: 0 to 180°F (-18 to 82°C).

Type H: 0 to 250°F (-18 to 121°C) at 1800 RPM or less, 0 to 225°F (-18 to 107°C) above 1800 RPM.

**Contact your Imo Pump representative for guidance in applications which exceed the above limits, i.e. viscosities less than 2 cst, greater than 15,000 SSU (3250 cst), inlet pressures or temperatures greater than above, etc.**

## Speed

Maximum speeds shown by curve terminations on GPM-RPM graph. A maximum speed of 1800 RPM is recommended when pumping residual and crude oils due to the presence of abrasives and contaminants.

## Drive

Direct, belt, gear or chain. Also available in sealless magnetic drive configurations.

## Rotation

Clockwise facing pump shaft. Counterclockwise optional on sizes 156 thru 400 (except sizes 187Y, 187M & 218L pumps).

## Mounting

May be foot mounted in any attitude. Optional flange mounting available for horizontal or vertical applications.

## Accessories

Adapters for NEMA "C" face motors, steel baseplates and completely mounted pump/driver assemblies, ANSI RF flange spool pieces, etc.

## Filtration

Inlet strainers are required to keep contaminants and abrasives out of the pump. They must be selected in consultation with the strainer vendor to prevent pump starvation. Normally, 60 mesh (0.01 inch – 238 micron) for light and 1/8-3/16 inch (3 – 5mm) openings for heavy oils are recommended.

On the cover...3D sizes 218 and up have ANSI flanged inlets and 4-bolt, socket weld outlet connections.



# 5-400 GPM (19-1500 L/M) Pressure to 500 PSIG (35 BAR)

Series 3D is a general purpose three screw pump available in 19 different displacements. These pumps incorporate full hydraulic balance which cancels axial and radial thrust loads due to discharge pressure.

Mechanical sealed pumps have a single external ball bearing that does not rely on the lubricating qualities of the pumped liquid. The pumps are equipped with replaceable housings (liners) and most sizes are

available with an optional steel case. Axial inlets also available in most sizes.

Series 3D pumps are applied for lubrication services, fuel oil transfer and burner applications, hydraulic elevator supply, coolants and many other industrial uses. Very low airborne noise levels are normal for 1mo three screw positive displacement pumps as are high operating efficiencies and non-pulsating delivery of flow.

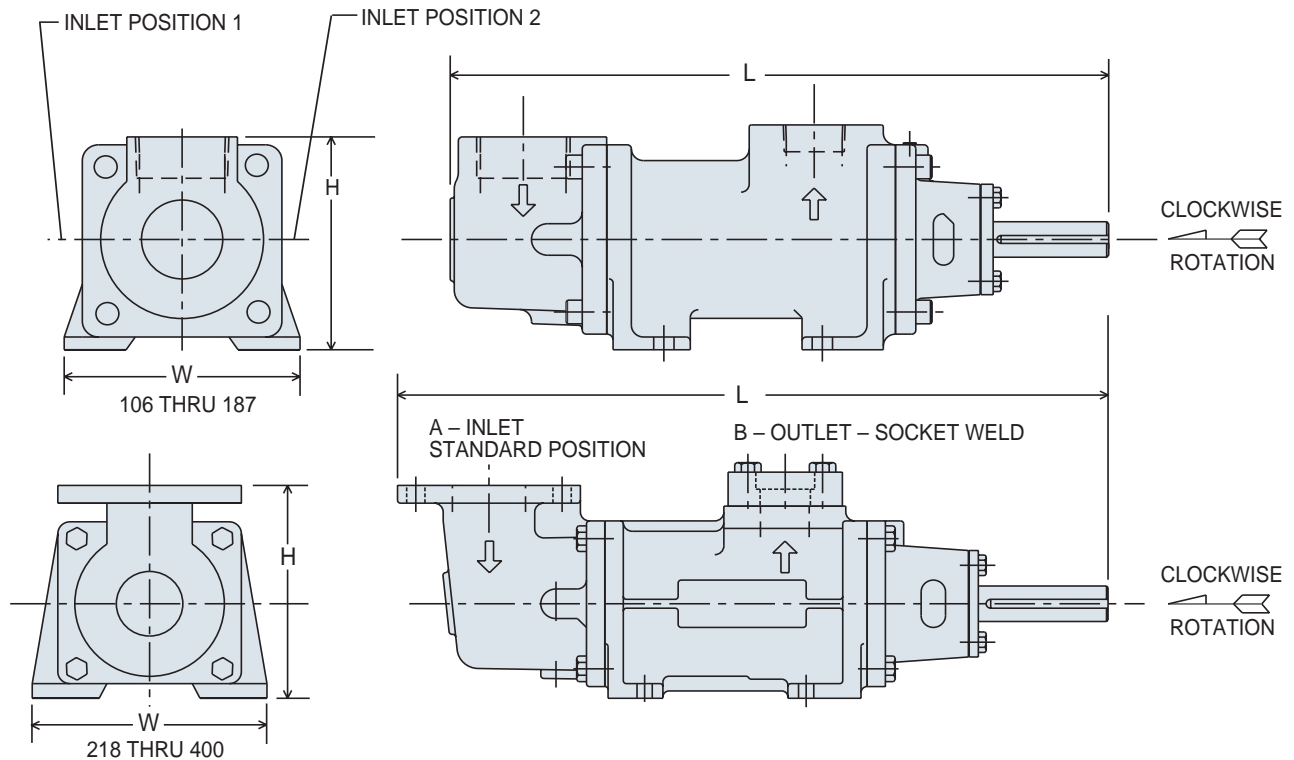

Size	A		B		H		L		W		WEIGHT	
	INCH	MM	INCH	MM	INCH	MM	INCH	MM	INCH	MM	LBS	KG
106	1	25.4	1	25.4	5 5/8	143	14 7/16	367	6	153	41	18.6
118	1 1/2	38.1	1	25.4	5 7/8	150	15 1/4	388	6 1/4	159	44	20
137	1 1/2	38.1	1	25.4	6 1/8	156	16 11/16	424	6 1/2	166	50	22.7
156	2	50.8	1 1/2	38.1	6 1/2	166	18 5/8	474	7	178	66	30
187, Y, M	2 1/2	63.5	1 1/2	38.1	6 3/4	172	20 5/16	516	7 1/2	191	82	37.3
218,L	3	76.2	2	50.8	9	229	29 3/16	742	9	229	154	70
250,P	4	101.6	2 1/2	63.5	10 3/4	273	32 1/4	820	10	254	202	91.8
275,E	4	101.6	3	76.2	11 1/8	283	32 11/16	831	11	280	246	112
312,P	4	101.6	3	76.2	11 3/4	299	35 1/4	896	12	305	281	128
337,350	5	127	4	101.6	13 1/4	337	38 9/16	980	13	331	410	186
400,P	6	152.4	4	101.6	16	407	41 5/8	1058	14	356	601	273

Cast iron, sizes 106 thru 187 have NPT inlet and outlet ports.

Sizes 218 up, flanged inlets are 125# ANSI FF for iron cased pumps and 150# ANSI FF for cast steel.

Cast steel size 156 has socket weld inlet and outlet ports.

Cast steel size 187 has socket weld outlet and 150# ANSI FF flange inlet.





## motralec

4 rue Lavoisier . ZA Lavoisier . 95223 HERBLAY CEDEX

Tel. : 01.39.97.65.10 / Fax. : 01.39.97.68.48

Demande de prix / e-mail : [service-commercial@motralec.com](mailto:service-commercial@motralec.com)

[www.motralec.com](http://www.motralec.com)



ALLWEILER



HOUTTUIN



IMO PUMP



WARREN



Bulletin 3D-02



Quality Management System