

- Casing:** High shock capacity ductile (nodular) iron is standard in sizes 400 and 462 (cast steel optional). Size 630 & 912 utilize a steel case.
- Rotor Housing:** Bimetal construction - steel with thick Babbitt liner.
- Power Rotor:** Alloy steel, nitride hardened and fully ground.
- Idler Rotors:** Alloy steel, nitride hardened and fully ground.
- Gaskets:** Fluoroelastomer.
- Seal & Bearing:** Positive drive mechanical seal with carbide faces, fluoroelastomer O-rings and external ball bearing.
- Accessories:** Completely mounted, built to order pump/driver assemblies available with bedplates, ANSI RF spool pieces, RTDs, vibration sensors, etc.



Outlet Pressure: 1500 psig (138 bar-g) maximum, bimetal construction, all sizes.
2000 psig (138 bar-g) most sizes.
40 psig (2.8 bar-g) minimum allowable.

Inlet Pressure: Sizes 400 & 462 100 psig (6.8 bar-g) maximum.
Size 630 150 psig (10.3 bar-g) maximum.
Size 912 250 psig (17.2 bar-g) maximum.
Modification to higher pressures available in all sizes - consult factory.

Viscosity: 60 SSU (10 cSt) to 25,000 SSU (5,400 cSt) - consult factory for lower or higher viscosities.

Temperature: 0 to 250 °F (-18 to 121 °C) - consult factory for temperatures above 200 °F (93 °C).

Shaft Speed*: Sizes 400 and 462 - 2300 rpm maximum - consult factory for speeds above 1800 rpm.
Sizes 630 and 912 - 1500 rpm maximum.

Drive: Direct only.

Rotation: Clockwise facing pump shaft.

Mounting: Foot mounted.

Port Locations: Outlet port upward. Suction port rotatable in minimum 90° increments.

Filtration: Inlet strainers are recommended to keep contaminants and abrasives out of the pump. They must be selected in consultation with the strainer vendor to prevent pump starvation. Normally recommended are (0.01 inch - 0.25 mm) for light oils and 1/8 - 3/16 inch (3 - 5 mm) openings for heavy oils.

*Assumes minimum inlet pressure requirements are met.

motralec
4 rue Lavoisier . ZA Lavoisier . 95223 HERBLAY CEDEX
Tel. : 01.39.97.65.10 / Fax. : 01.39.97.68.48
Demande de prix / e-mail : service-commercial@motralec.com
www.motralec.com

Imo Series 8L Pump: Critical fluid-handling applications

110 to 2900 gpm (25 - 660 m³/h), pressure to 2000 psig (138 bar-g)

You need to save energy costs. You need to operate with very high efficiencies. Imo 8L series pumps are designed for pipeline transport in medium to high pressure service on crude oils, fuel oils and other petroleum products. Pumps consistently operate with very high efficiencies, typically over 80%. Energy costs are a significant portion of total pipeline operating expenses. Utilizing 8L series pumps from Colfax can appreciably reduce these costs when compared to centrifugal pumps. The 8L series also finds extensive use in steam/electric power plants as the burner pumps supplying fuel to the boilers. Many systems are equipped to handle distillate fuel oil, low sulfur and residual oils with standard Imo 8L pumps. This flexibility allows optimum fuel use depending on price and availability.

Dimensions & Weights

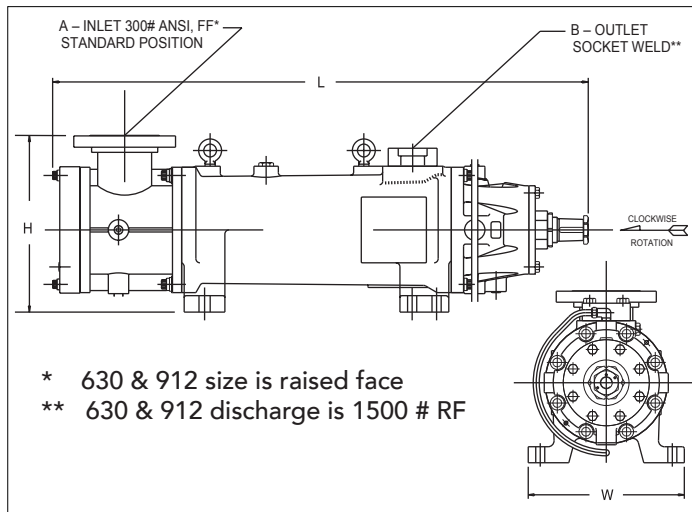

	SIZE	400	462	630	912
A	inch	6	8	10	12
	mm	152	203	254	305
B	inch	3	4	8	10
	mm	76.2	102	203	254
H	inch	21.5	24.5	32	43.1
	mm	546	622	813	1,095
L	inch	64.4	72.3	90.4	125
	mm	1,636	1,837	2,297	3,166
W	inch	19.5	25	27	40
	mm	495	635	686	1,016
WEIGHT	lb	1,665	2,480	6,351	15,550
	kg	757	1,128	2,287	6,872

