

Floor mounted compact drainage water and effluent box with stainless steel submersible pump

Saniquick A

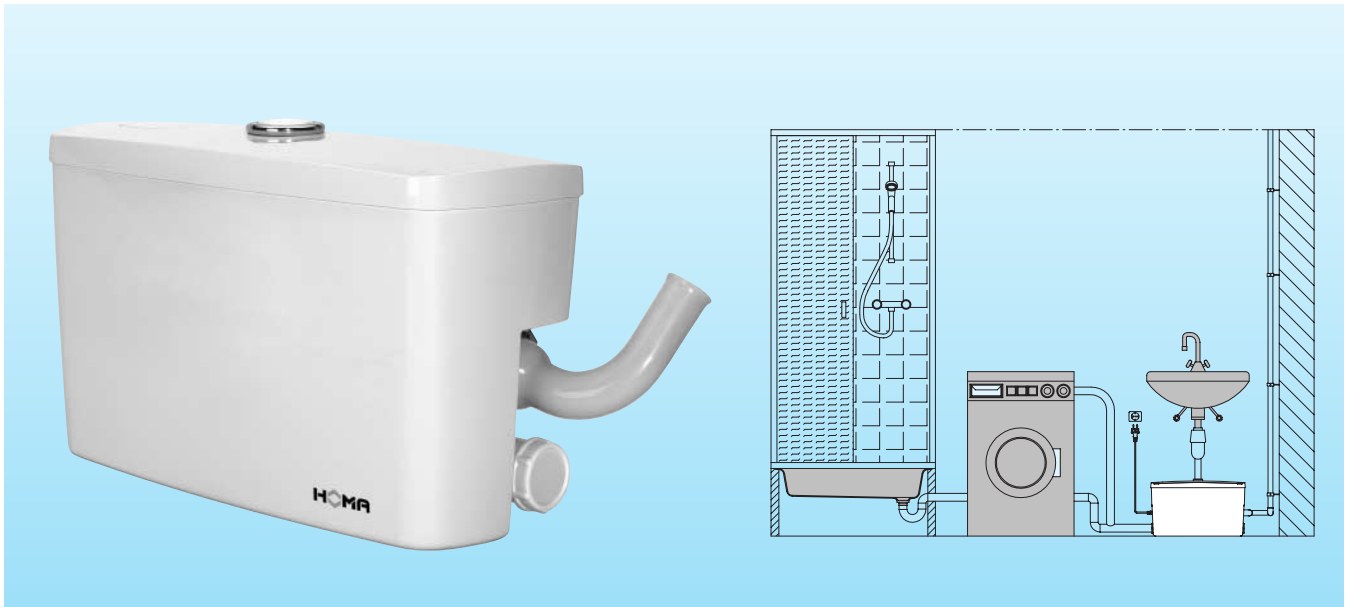

Application

Compact mini pump station for sanitary installations with hand basins, washing machines or showers in basement apartments or cellars which are below sewer backwaste level. The Saniquick A is also the ideal solution for subsequent installation of sanitary facilities. The built-in stainless steel drainage pump operates automatically by a floatswitch control. The discharge pipe with 1" minimum diameter can be easily installed with minimum construction work. The Saniquick's compact design allows installation directly under the hand basin, where space is at a premium.

DIN EN 12050-2: Conformity and design approved and controlled by LGA, Certificate No. 0220119.

Pumped liquid: Domestic drainage water and effluent.

Maximum liquid Temperature: 35°C, short term up to 60°C.

Operation: Intermittent.

Design

Compact domestic effluent disposal unit comprising:

Collection Tank: Odour-tight plastic collection tank. Maximum utility volume 15 litres. One top inlet DN 40. Two lateral inlets DN 40 with integrated non-return valve. Discharge 25 mm diameter with integrated non-return valve. Air vent with activated carbon filter.

Pump: Single-stage centrifugal pump with horizontal discharge.

Motor: Single-phase electric motor with thermal sensors embedded in the winding. Insulation Class B. Degree of protection IP 68. Stainless steel rotor shaft, pre-lubricated bearings.

Shaft Seals: Double shaft seal rings.

Pump Operation Control: Pneumatic level control.

Materials:

Collection tank	Composite
Pump housing	Glass fibre reinforced composite
Impeller	Composite
Motor housing, rotor shaft	Stainless steel 1.4301

Technical Data

Motor input P ₁	650 W
Motor output P ₂	350 W
Voltage	230V-240V / 1 Ph 50 Hz
Speed	2900 rpm
Nominal current	2.1 A
Cable	H 07RNF3G1
Insulation Class (complete appliance)	IP 44
Weight	8 kg
Discharge	DN 25

Equipment supplied

Tank with pump, 1.1 m of cable with plug.

Performance

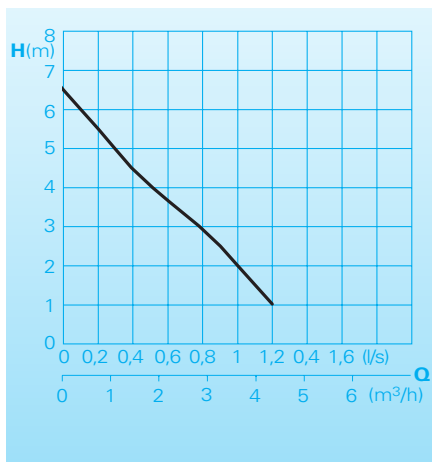

Installations

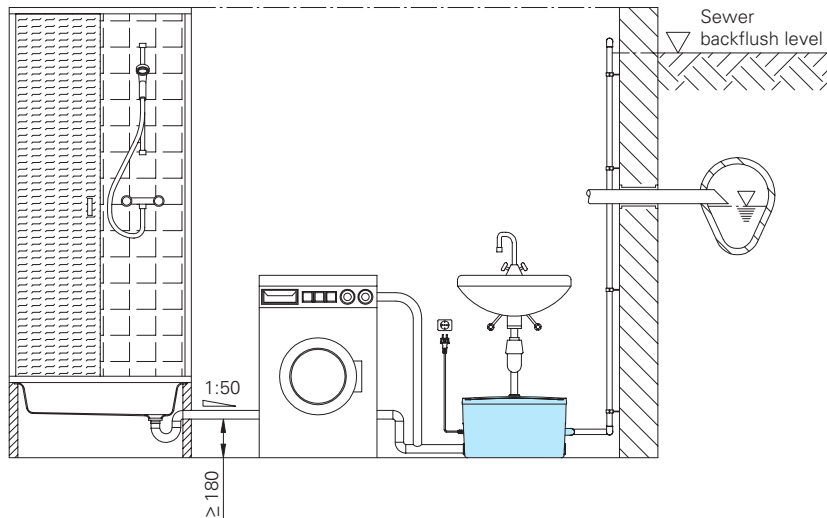

Accessories

Part Description	Dimension	Part No.
Bronze gate valve	BSP 1" F	2216010
	BSP 1 1/4" F	2216012
	BSP 1 1/2" F	2216015
90° galvanized elbow	BSP 1" F/M	2111305
	BSP 1 1/4" F/M	2111405
	BSP 1 1/2" F/M	2111505
Galvanized union piece	BSP 1" M/F	2114303
	BSP 1 1/4" M/F	2114304
	BSP 1 1/2" M/F	2114305

Dimensions

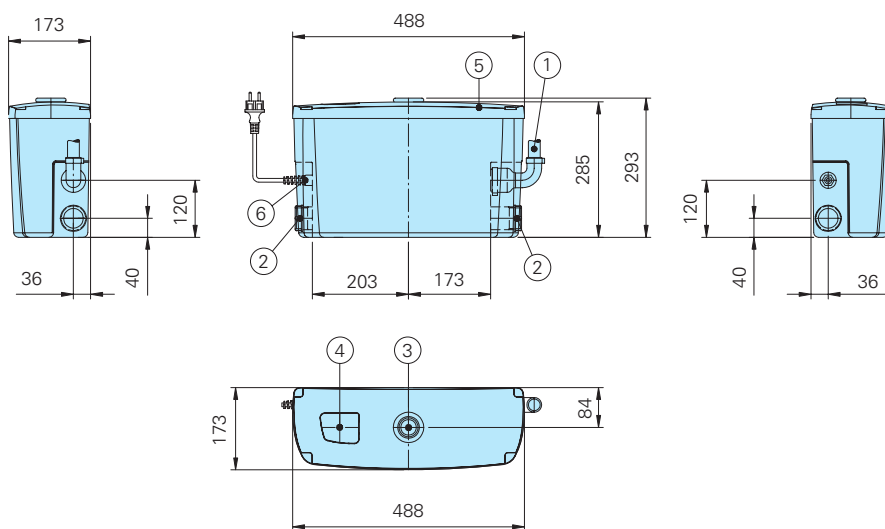

- ① Connection for discharge 25 mm dia.
- ② Screw for inlet DN 40 (40 mm dia.).
- ③ Inlet for hand basin (40 mm dia.)
- ④ Air vent with activated carbon filter
- ⑤ Tank cover, screwed
- ⑥ Cable inlet

all dimensions in mm.

motralec

4 rue Lavoisier . ZA Lavoisier . 95223 HERBLAY CEDEX
 Tel. : 01.39.97.65.10 / Fax. : 01.39.97.68.48
 Demande de prix / e-mail : service-commercial@motralec.com

www.motralec.com

HOMA
 P U M P T E C H N O L O G Y