

## Deepwell submersible pumps with 3" diameter for clear water

### H 832

#### Application

HOMA high pressure submersible pumps are suitable for pumping clear water with high pressure from bore holes or narrow wells. They are used for domestic water supply, irrigation, garden watering from cisterns or similar, in fountain displays, watering place, ground water drainage etc.

In combination with the electronic control panel HPS 2 or with a pressure tank, pressure switch and an electrical control panel the pumps can operate automatically (see accessories).

Installation: The pumps operate in vertical or horizontal position. For vertical operation in a well the pump must be suspended on a rope.

Pumped medium: Clear water.

Max. medium temperature: 35°C.

Operation: Permanent.

#### Design

Fully submersible pump consisting of:

Pump: Multistage centrifugal pump with vertical discharge BSP 1" F.

Impeller: Closed multi-channel impellers, spherical clearance 1,5 mm. Wear rings made of stainless steel.

Motor: Fully submersible, pressure tight electric motor, oil filled. Insulation class F. Motor protection IP 68. Thermal sensors embedded in the motor winding.

Shaft/bearings: Large diameter stainless steel rotor shaft, pre-lubricated bearings.

Seals: Mechanical seal.

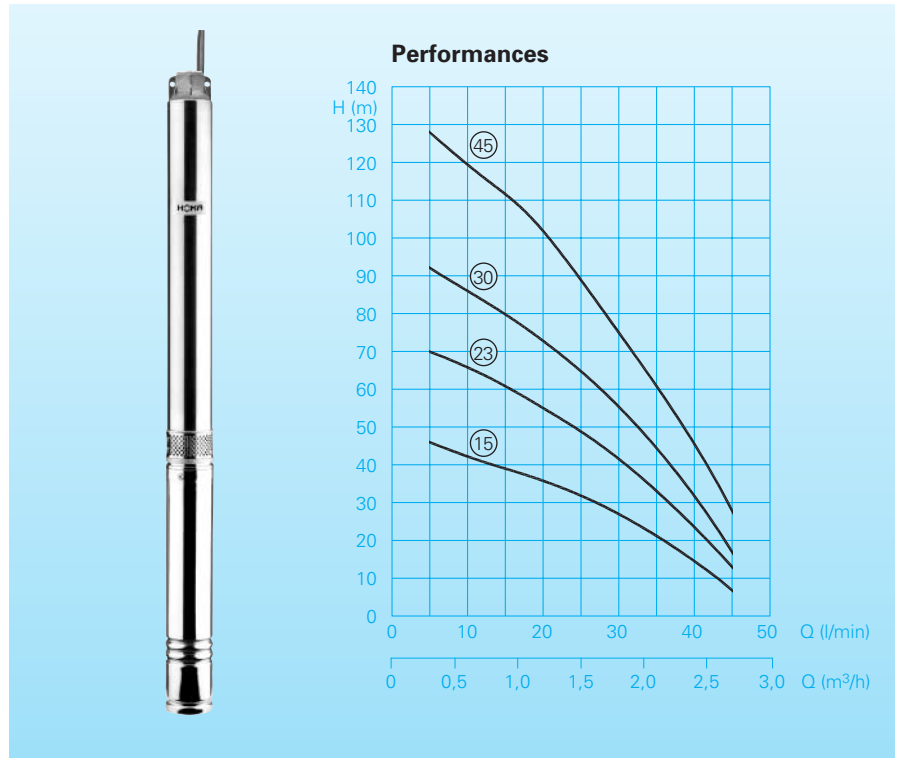

#### Technical Data

Curve No.	Pump type	Motor-output P <sub>2</sub> (kW)	Voltage 50 Hz (V)	Nominal current (A)	Cable length (m)	Weight (kg)
15	H 832-15/0,37 W	0,37	230/1Ph	3,75	1,5	9,3
15	H 832-15/0,37 D	0,37	400/3Ph	2,00	1,5	9,3
23	H 832-23/0,55 W	0,55	230/1Ph	4,50	1,5	10,8
23	H 832-23/0,55 D	0,55	400/3Ph	2,10	1,5	10,5
30	H 832-30/0,75 W	0,75	230/1Ph	5,85	1,5	12,4
30	H 832-30/0,75 D	0,75	400/3Ph	2,50	1,5	12,0
45	H 832-45/1,10 D	1,10	400/3Ph	3,20	1,5	14,4

Speed: 2900 rpm

Discharge: BSP 1" F

#### Materials:

Pump housing	Stainless steel
Motor housing, Suction sieve, Motor shaft	Stainless steel
Impeller	Glass-fibre reinforced synthetic material (composite)
Mechanical seal	Carbone graphite / Stainless steel
Elastomere	NBR

#### Equipment supplied

Pump with integrated non-return valve and 1,5 m of cable.

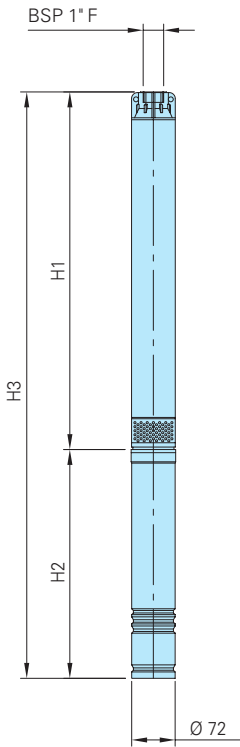

Domestic water supply system with electronic control box HPS 2

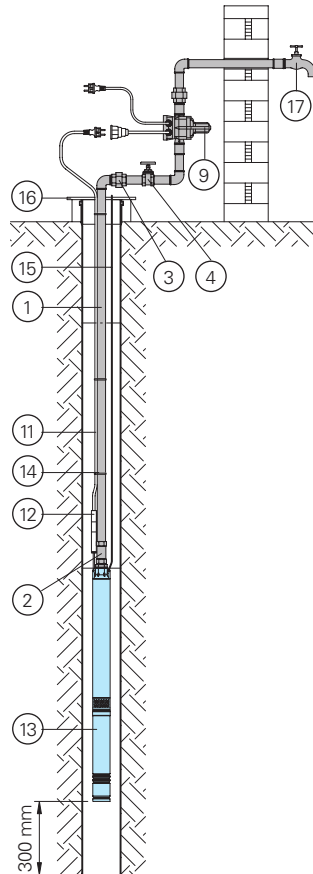

Domestic water supply system with diaphragm pressure tank

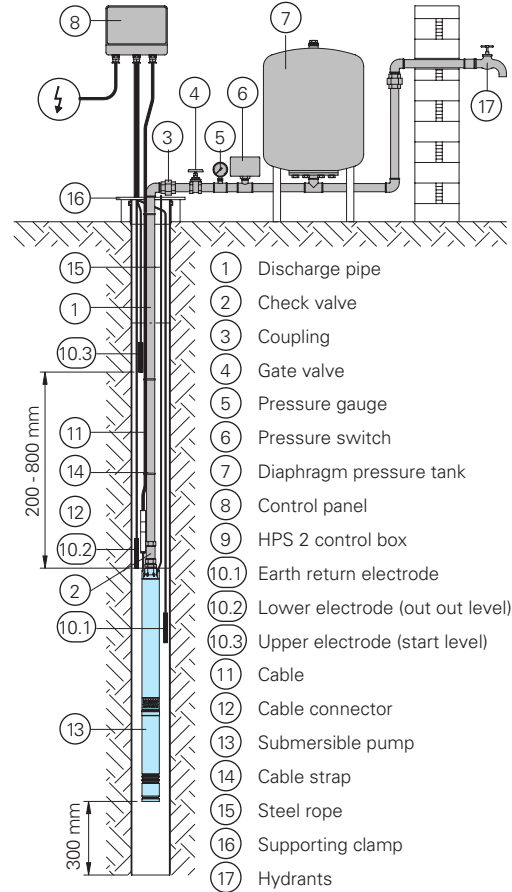

Pump type	H1	H2	H3
H 832-15/0,37 W	580	371	951
H 832-15/0,37 D	580	371	951
H 832-23/0,55 W	780	371	1151
H 832-23/0,55 D	780	371	1151
H 832-30/0,75 W	1000	391	1391
H 832-30/0,75 D	1000	391	1391
H 832-45/1,10 D	1380	410	1790

All dimensions in mm.

Part Description	Dimension	Part-No.
① Galvanized tube, per m	BSP 1"	2100150
○ Galvanized fittings,		on request
○ Tube PE-HD, polyethylene		on request
○ Screw connection, PE-HD		on request
○ Reinforced hose, per m	BSP 1"	2632025
○ Brass STA-hose coupling	BSP 1"	2001310
○ Hose band	BSP 1"	2302330
② Bronze non-return valve	BSP 1" F	2211113
③ Galvanized coupling	BSP 1" F	2114303
④ Bronze gate valve	BSP 1" F	2216010
⑤ Manometer 0 – 10 bar	BSP 1/4" M	8503240
⑥ Pressure switch	BSP 1/4" M	1254011
⑦ Diaphragm pressure tank		on request

Part Description	Dimension	Part-No.
⑧ Single phase control panel with motor	0,37 kW	1921010
protection, capacitor, on-off-switch- plug, up to	0,55 kW	1921012
	0,75 kW	1921014
○ Single phase control panel as above, additional with dry run protection, up to	0,37 kW	1921040
	0,55 kW	1921042
	0,75 kW	1921044
○ Three phase control panel with motor	0,37 kW	1926010
protection, on-off-switch, CEE-plug, up to	0,75 kW	1926015
	1,1 kW	1926020
○ Three phase control panel as above, additional with relay and 2 electrodes (mounting a plastic tube a third electrode must be used as an earth conductor), without cable, up to	0,37 kW	1921070
	0,75 kW	1920172
	1,1 kW	1921074
⑨ HPS 2 electronic pump control box with dry-run protection	BSP 1" M	1468560
⑩ Electrode		1610992
⑪ Rubber-sheated cable, per m		1041541
⑫ Coupling sleeve		1124020

**motralec**

4 rue Lavoisier . ZA Lavoisier . 95223 HERBLAY CEDEX

Tel. : 01.39.97.65.10 / Fax. : 01.39.97.68.48

Demande de prix / e-mail : service-commercial@motralec.com

[www.motralec.com](http://www.motralec.com)

**HOMA**  
P U M P T E C H N O L O G Y