

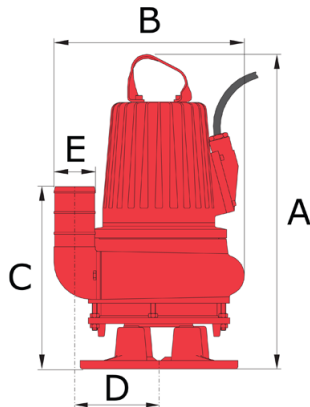

Bravo 200

Electrical submersible slurry pump



50 Hz	Bravo 200
Discharge connection E	4"
Rated power P_2	4,7 kW
Max. power consumption P_1	5,7 kW
Shaft speed rpm	1445 rpm
Rated current at 230V	17 A
Rated current at 400V	9.6 A
Rated current at 500V	7.7 A
Solids passage	50 mm
Dimensions A / B / C / D	760 / 460 / 440 / 157 mm
Weight	157 kg

Other voltages on request

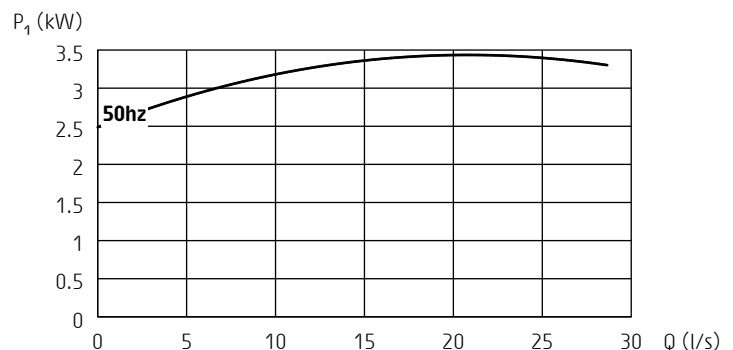
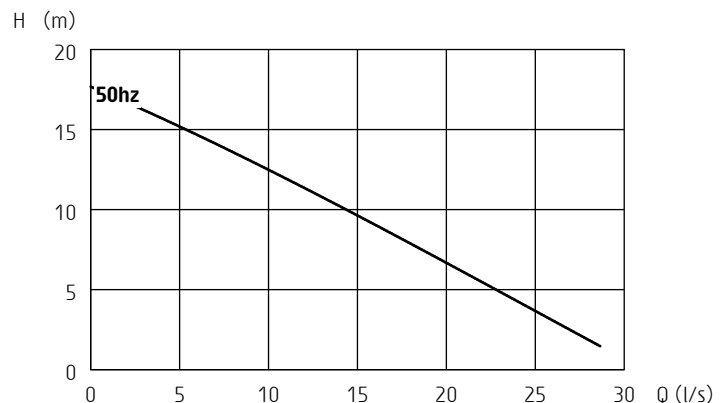

ISO 9906/A

General description

Submersible pump for pumping water containing abrasive particles, ground water, slurries

Classification

Electrical submersible slurry pump
Protection class: IP 68

Electrical motor

Squirrel cage induction motor
Insulation class: H (IEC 85), DOL or star/delta

Motor protection

Thermo switches in motor windings

This pump must be used with external motor protection in accordance with technical data

Cable - SubCab 20 m (66 ft)

DOL: 4x2.5mm² + 2x1.5mm²
Y/D: 7x2.5mm² + 2x1.5mm²

Shaft seals

Double mechanical seal running in an oil compartment
Material lower seal: tungsten carbide - tungsten carbide
Material upper seal: tungsten carbide - aluminium oxide

Materials

Drive unit: *Cast iron*
Pump housing: *Cast iron*
Impeller: *Hard-Iron™*
Discharge connection: *Cast iron*
Wear plate: *Nitrile rubber*
Lifting handle: *Galvanized steel*
Shaft: *Stainless steel*
Studs, screws and nuts: *Stainless steel*
O-rings: *Nitrile rubber*

Limitations

Max. submersion depth: 20 m (66 ft)
Max. liquid temperature: 40 °C (104 °F)
Allowed pH range: 5.5 - 14