

ISO
9001

CERTIFIED GROUP

VAP-MVO

Sealless cantilever vertical pumps for corrosive/slurry applications.

Industries :

- Chemical industry
- Petrochemical industry
- Offsite refinery
- Steel industry
- Mineral/mining industry
- Pulp and paper industry
- Food industry
- Various industry (slurry)



ENSIVAL-MORET

www.motralec.com
service-commercial@motralec.com

VAP-MVO

VAP MVO	34	NCK...	40	32	IN
Pump Family	Frame size	Original hydraulic family	Discharge orifice (in mm)	Impeller diameter (in cm)	Optional inducer

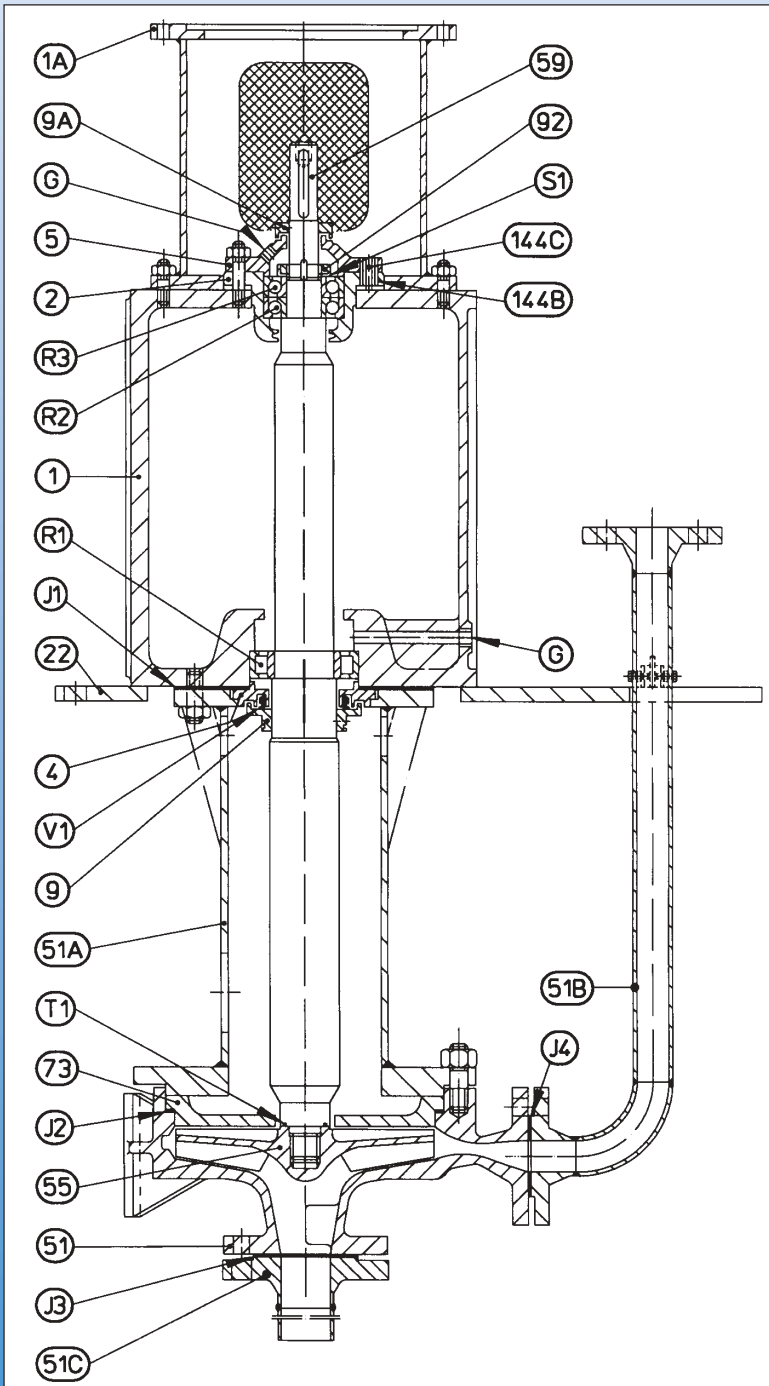

REP.	DESIGNATION
1	BEARING FRAME
1A	MOTOR SUPPORT FRAME
2	BEARING HOUSING
4	BEARING COVER (LOWER)
5	BEARING COVER (UPPER)
9	DEFLECTOR (LOWER)
9A	DEFLECTOR (UPPER)
22	BASE PLATE
51	CASING
51A	SUSPENSION COLUMN
51B	DISCHARGE BEND
51C	SUCTION PIPE
55	IMPELLER
59	SHAFT
73	WEAR PLATE
92	BEARING LOCK NUT
144B	HELICOIL
144C	ROTOR SET SCREW
R1	BEARING
R2	BEARING
R3	BEARING
S1	SAFETY WASHER
G	GREASE-NIPPLE
V1	V-RING
T1	O-RING
J1	GASKET
J2	GASKET
J3	GASKET
J4	GASKET

VAP-MVO

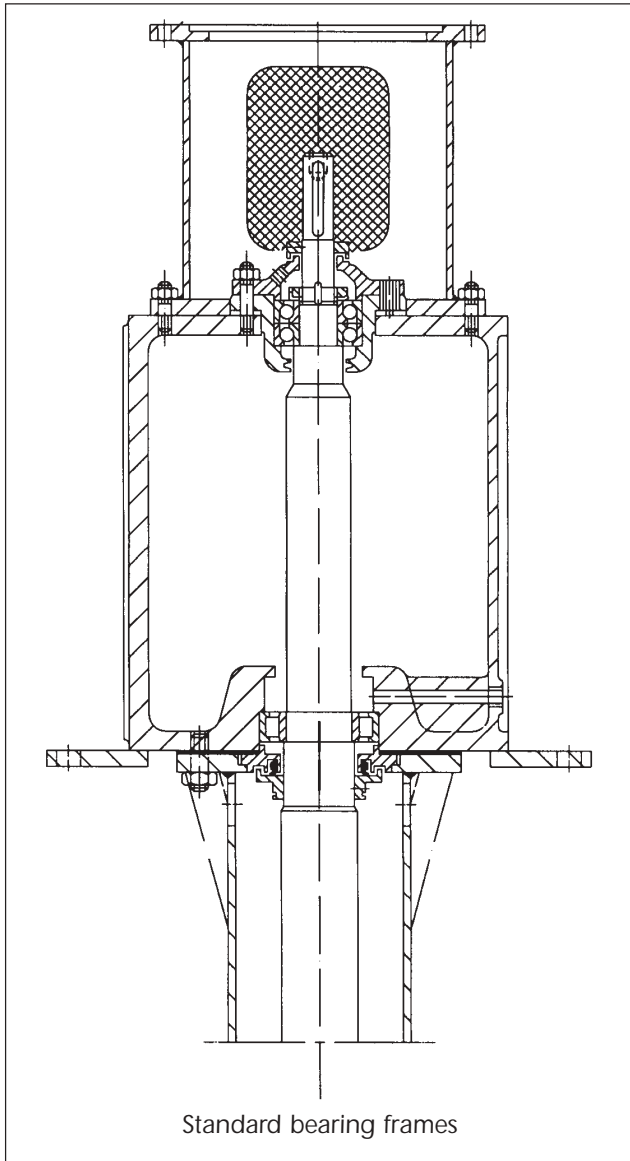

VAP - MVO ranges

Main features

- Vertical cantilever pumps
- No seal of any type
- No bearing in the liquid
- Various hydraulics for corrosives or slurries
- Dry running without limits

Materials

- Grey cast iron, Nihard cast iron, chromium cast iron.
- Carbon steel
- Stainless steel: Austenitic, Super-austenitic or Duplex
- Special materials to survive in the most hostile environments are available, such as Hastelloy B or C, Titanium, Nickel....

Design

- Designed to accept all type of hydraulics; close, semi-open, open or vortex impellers.
- Suitable for all kind of liquids with flexible constructions, speed and materials.
- No submerged bearing or tight clearances gives a unique capacity to run dry and accept unsteady process conditions.
- No oil or water lines required to lubricate a classical bottom bearing.
- Cantilever shaft operate safely under first critical speed.
- Simple design giving low and easy maintenance.
- Grease lubricated ball bearings are located above the floor plate and are sealed from contamination.
- Oversized column pipe provides perfect alignment between bearing frame and pump casing.
- Discharge pipe is separate from shaft line.
- An optional suction pipe allows the pump to operate with a liquid level dropping down under the impeller level..

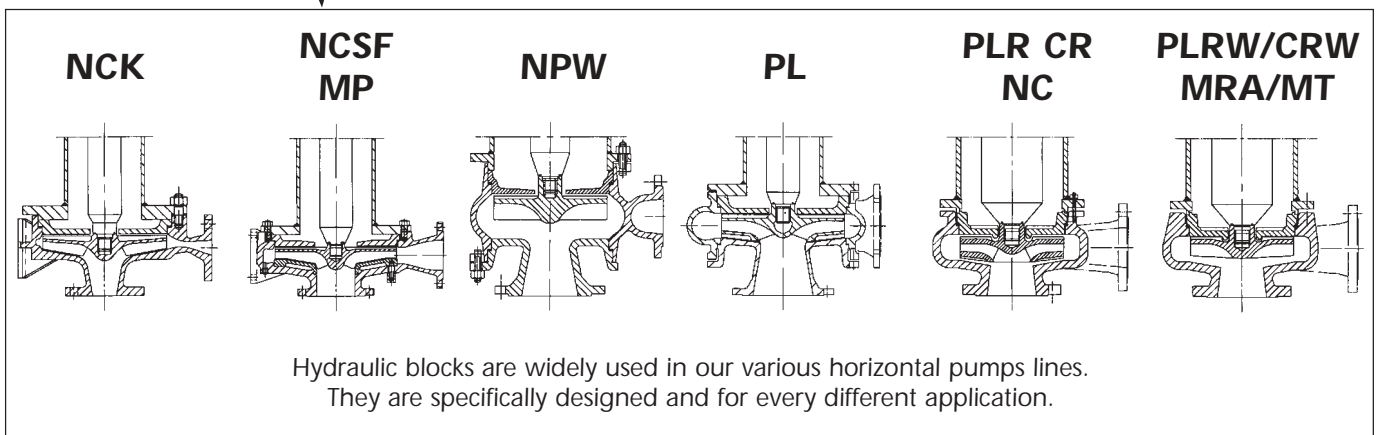



DRIVING ARRANGEMENT

1- Direct coupling with limited choice of speeds.

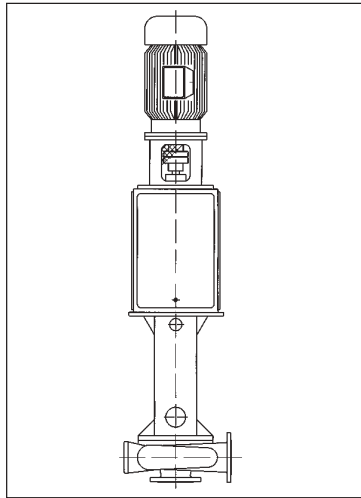

2- V-belt drive for greater flexibility in application. Tightening adjustment on motor frame

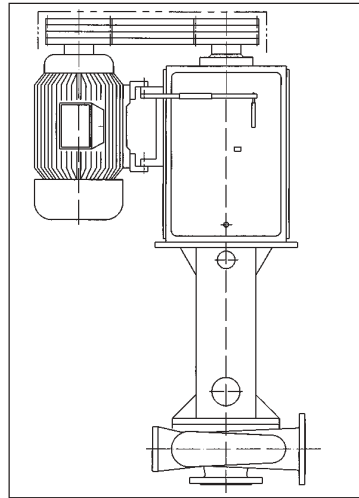

HORIZONTAL SUPPORT

1- Base plate under bearing frame

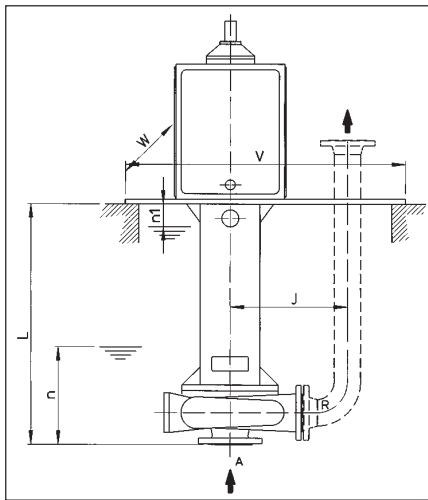

2- Base plate above bearing frame

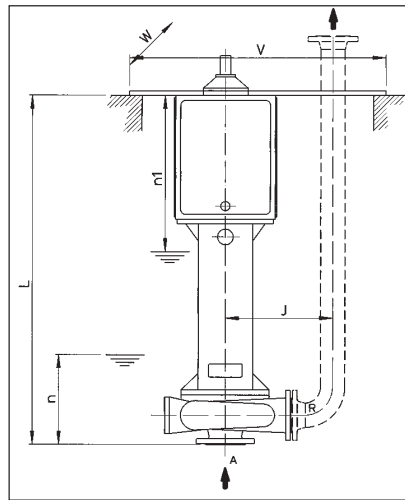

VERTICAL SUPPORT

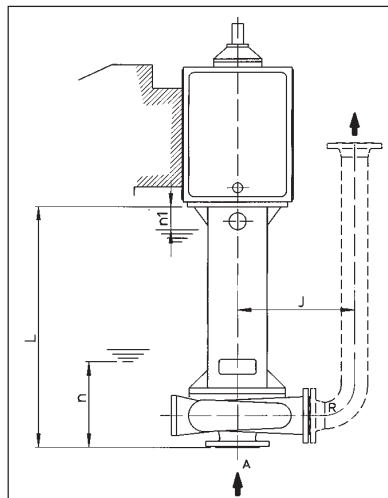

VERTICAL SUPPORT OUTSIDE A TANK

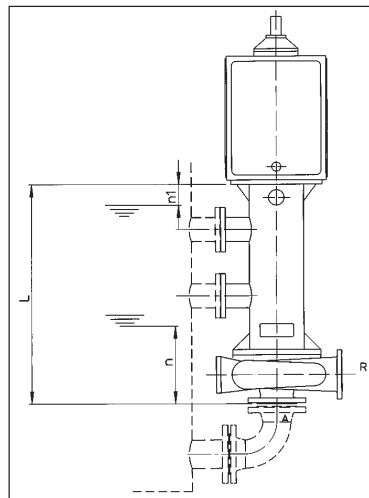

OPTIONAL CONSTRUCTIONS

High temperature construction.

Molten salts up to 850°F.

Integrated thermal barrier with air forced circulation.

Bearing cooled with circulating oil and fan.

"Z" design of discharge pipe to avoid thermal expansion stresses.



Jacketed construction.

Column and discharge pipe are provided with heating jacket for temperature control.
(molten sulfur)



PERFORMANCES

- Capacity : up to **14 500 USGPM**.
- Total head : up to **500 ft**.
- Operatin temperature range : standard construction up to **250 °F** ;
special construction up to **850 °F**.
- Maximum speed : up to **1800 rpm** according to size.
- Shaft length : up to **6 ft** according to size and speed.

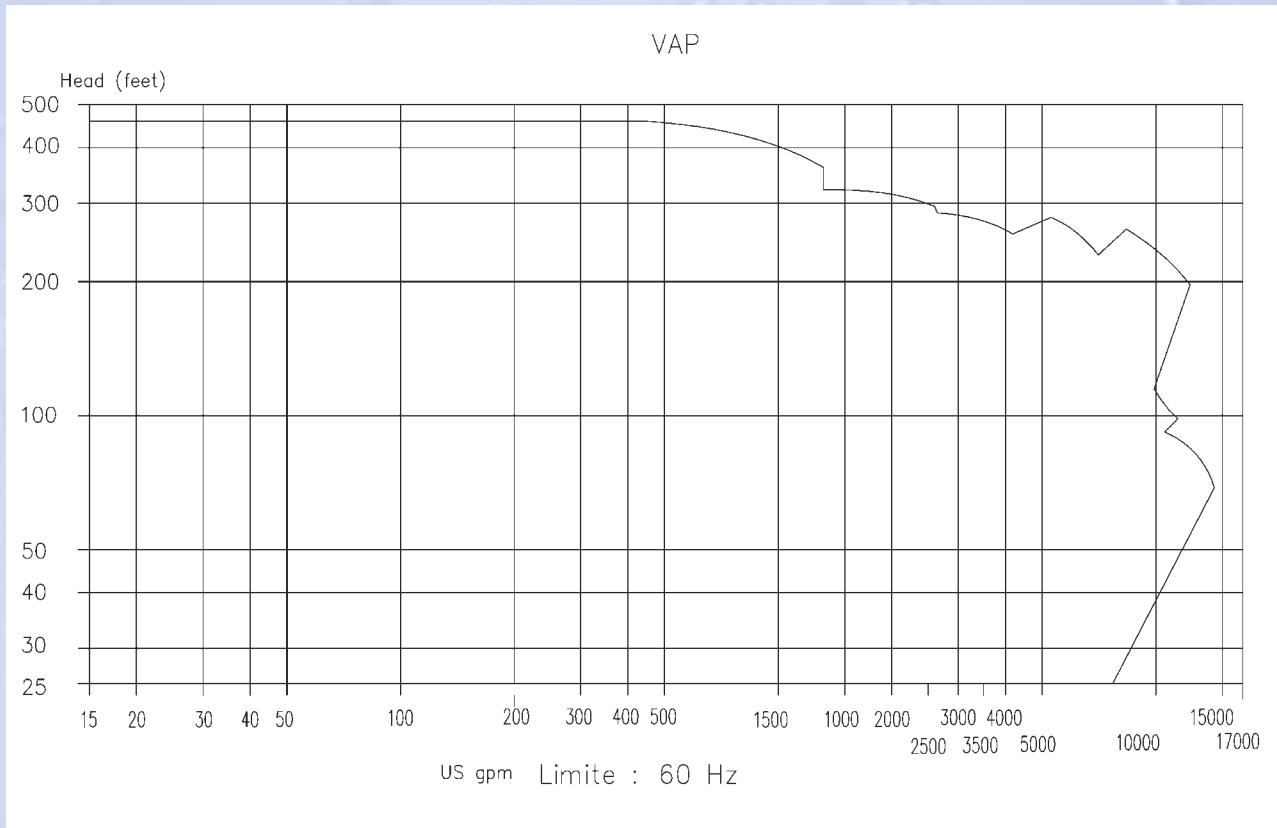

EM.EN.VAP -300403

TMRCA F1000 0032.87 23.20.08

