



# BARNES<sup>®</sup>

## SH Series

## Pumps

The Next  
Generation of

**SOLIDS** *Handling*

BARNES  
SH Series

**motralec**

4 rue Lavoisier . ZA Lavoisier . 95223 HERBLAY CEDEX

Tel. : 01.39.97.65.10 / Fax. : 01.39.97.68.48

Demande de prix / e-mail : [service-commercial@motralec.com](mailto:service-commercial@motralec.com)

[www.motralec.com](http://www.motralec.com)

**CRANE**<sup>®</sup>

PUMPS & SYSTEMS



# Clogging Resistance

We have heard from many Utility Customers that clogging of their Solids Handling pumps has become their biggest problem due to the ever increasing amount of solids entering the waste stream. Some of the items cited include towels, diapers, twine, panty hose, unraveled cleaning pads and toilet cleaner pads. The SH line of submersible Solids Handling Pumps has been designed and extensively tested with three types of impellers to minimize clogging:

**SHV Vortex** impellers provide excellent clog resistance, especially for stringy solids and at low flow, high head operation.

**SHM Monovane** impellers are used for applications with lower head where the concentration of velocity in the single passage effectively passes solids.

**SHD Dual vane**, enclosed impellers are effective on applications with high flow and head due to their large passage areas. All SH pumps have true 3" minimum spherical solids handling capability.

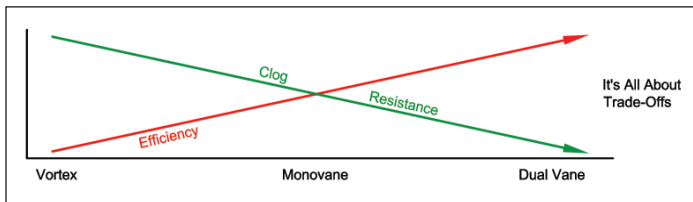

Flow rates have a very strong effect on solids handling capability. Many sources cite the need for a minimum velocity of 2.0 ft/sec (0.6 m/sec) for full horizontal pipes and 3.0 fps (0.9 m/sec) for vertical pipes. SH Solids Handling pumps are designed to operate successfully below these limits.

## Clog Testing

In order to confirm our design's abilities to minimize clogging, Crane Pumps & Systems conducted clogging tests in a special test rig. Various articles such as panty hose, dish

cloths, cloth diapers, rope, torn cleaning pads, stuffed animals and the like were pushed into the pump inlet one at a time, and then two at a time until the pump clogged, benchmarking against a number of popular competitive designs. Contact your Barnes Distributor if you would like to view video of several of these tests.

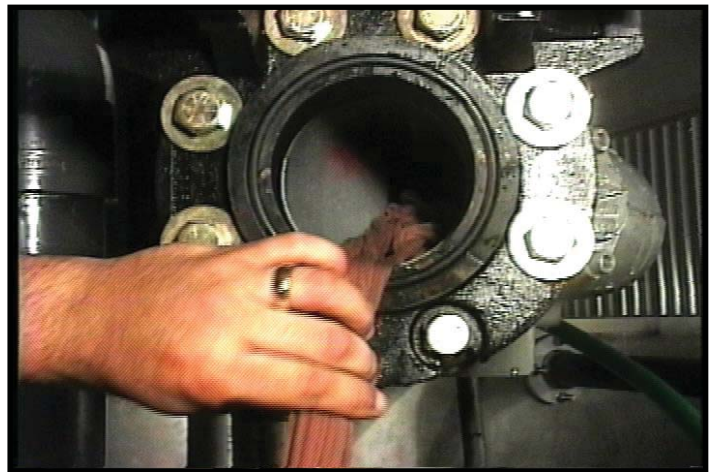

# Efficiency

Power consumption is an increasingly important consideration when selecting a Solids Handling pump. There is, however, a trade-off between pump efficiency and solids handling capability depending on the pump impeller selected.

The bigger issue is system efficiency, where the cost of sending a crew to service a clogged pump far outweighs the cost of extra power consumed, especially considering that most lift station pumps only operate part time.

One frequently used design technique to optimize power consumption is to use Variable Frequency Drives to operate pumps near the highest efficiency spot on the curve. This requires that the motors be equipped and rated for inverter use.

## Inverter Duty Rated

All the motors for the SH Solids Handling pumps are Inverter Duty Rated in accordance with NEMA Specification MG-1, Part 31. This includes the requirements for spike voltage resistance, brief over-speed and over-current conditions, etc.

SHV Vortex pumps are ideal for Inverter Duty use. In addition to the motor rating, the steep SHV curve shape greatly simplifies flow rate control.

The SH utilizes premium efficiency motors with spike-resistant Class H windings and varnish. The motors are certified to C22.2 No. 108-01 and compliant to UL 778 by CSA and have a 1.2 service factor. Stators are pressed into the motor housing for optimal heat conduction to the pumped fluid, and the housings are filled with non-toxic dielectric oil for both excellent heat transfer and ideal bearing lubrication.

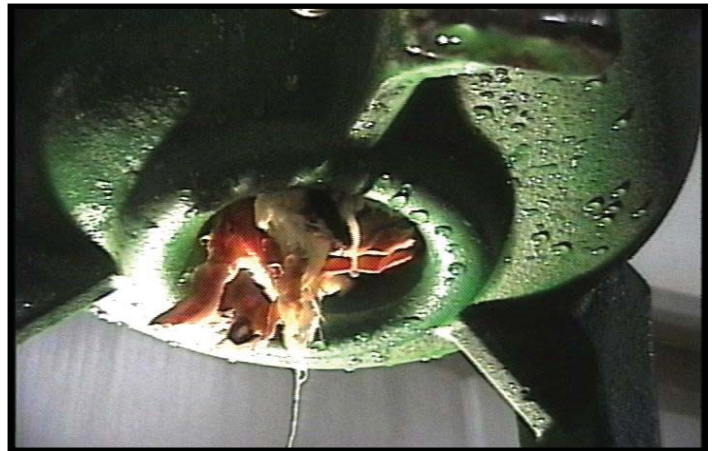

# Solids Handling Pumps

All pumps share the features shown below except for impellers and volumes

208-230/460-575 V  
Cord & Plug (Up to 100 ft)  
Internal wiring ch

**SHV Vortex** impellers provide excellent clog resistance, especially for stringy solids and at low flow, high head operation.

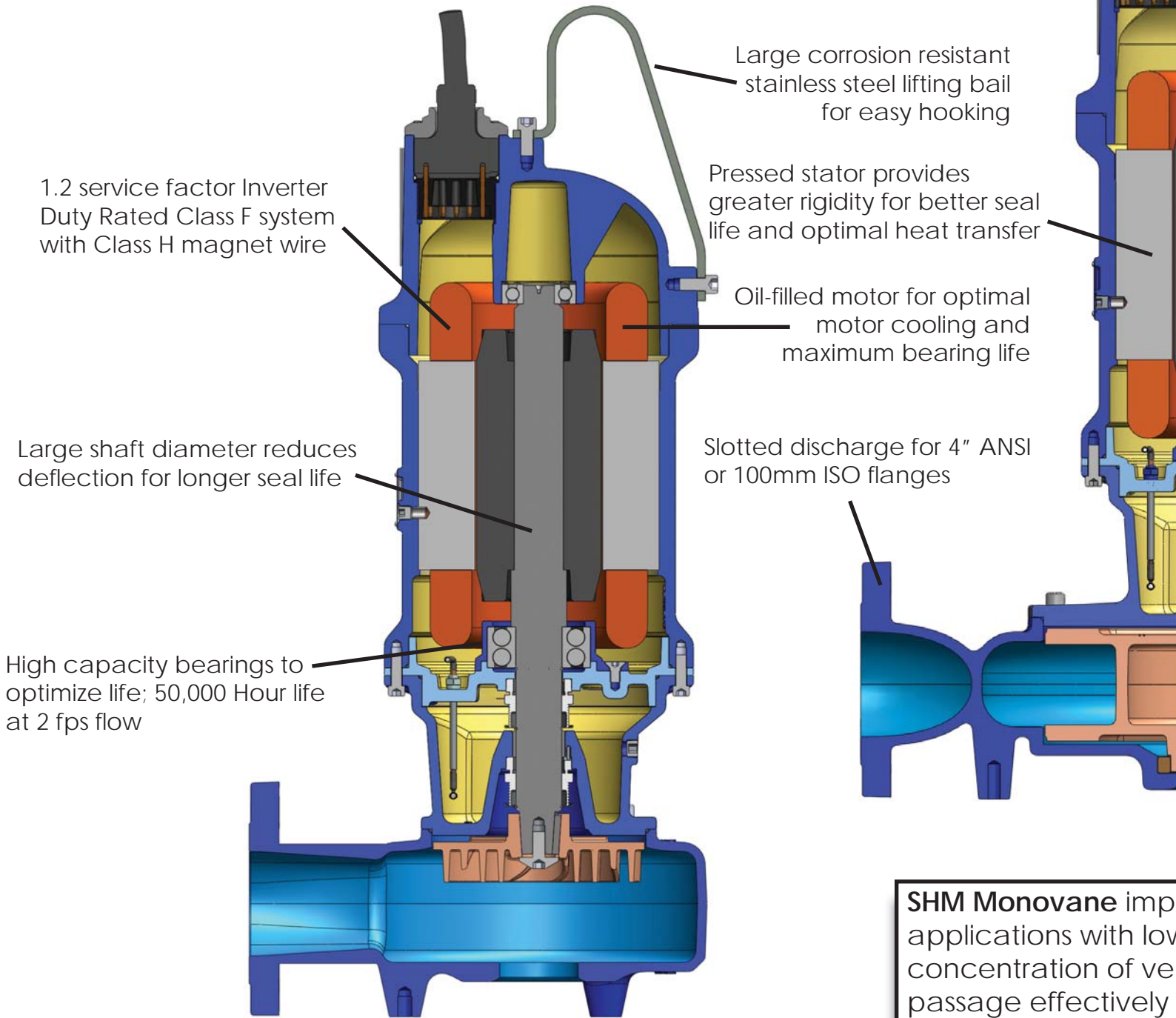

21 Frame Motor Shown

**SHM Monovane** impellers provide excellent clog resistance for applications with low concentration of velocity. The vanes pass through the discharge passage effectively.

V Selection Via  
to 20 HP) No  
anges required

**SHD Dual Vane**, higher efficiency enclosed  
impellers are effective on applications with high  
flow and head due to their large passage areas.

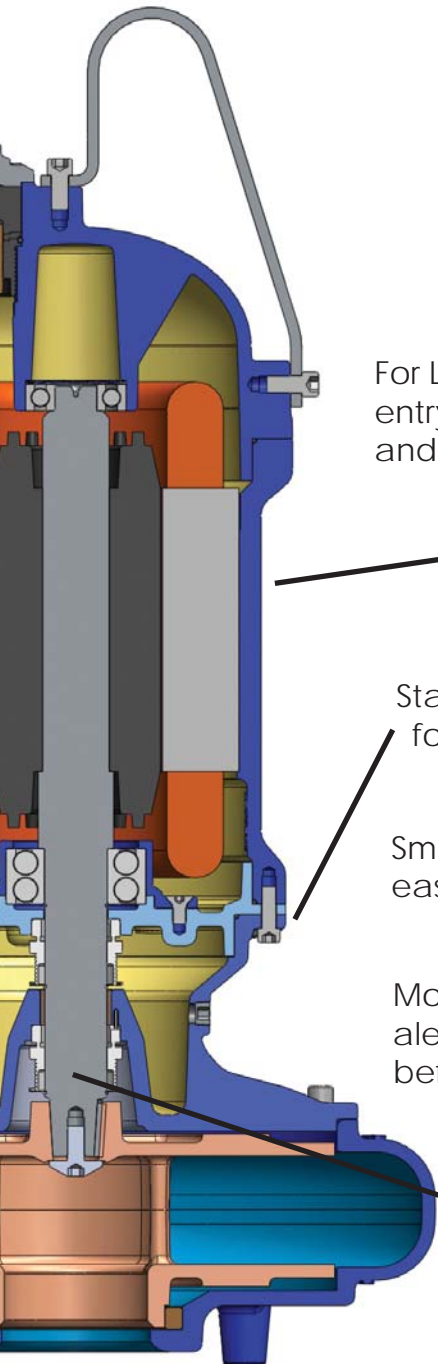

21 Frame Motor Shown

For Larger Conductor sizes, cord  
entry through double grommets  
and internal strain relief

2 coats of DuPont  
Corlar® epoxy coating

Stainless Steel hardware  
for corrosion resistance

Smooth castings for  
easy washdown

Moisture Detection Probe  
alerts pending seal problems  
before water can enter motor

Tapered, keyed shaft  
reduces vibration for  
increased seal life and  
makes shaft stronger

Impellers are used for  
higher head where the  
velocity in the single  
passes solids.

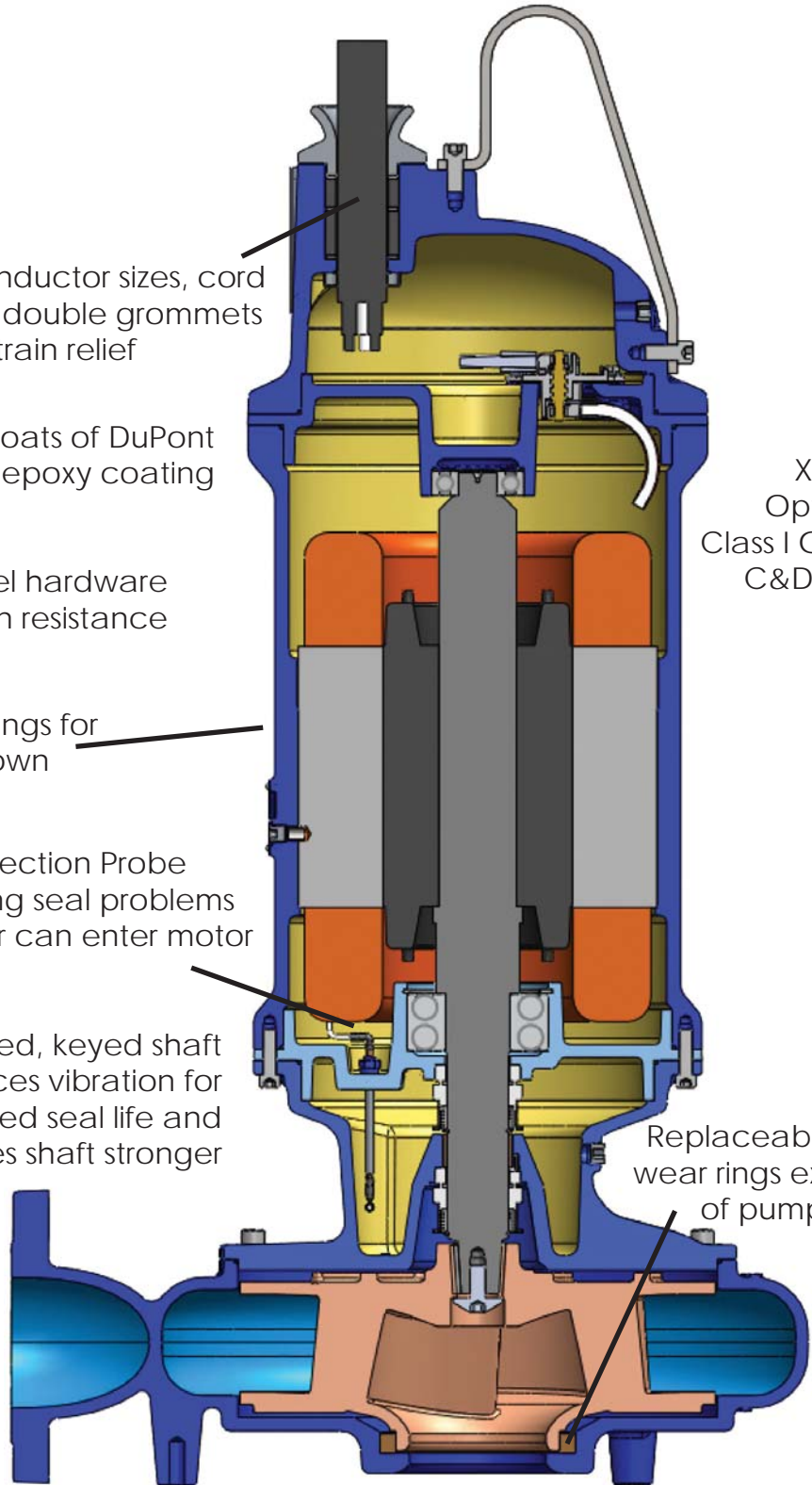

X-Pruf®  
Optional  
Class I Group  
C&D Div 1

Replaceable casing  
wear rings extend life of  
pump casings

28 Frame Motor Shown

# Cord and Entry

The cord combines power, temperature sensing and moisture sensor conductors into a single cable. Entry into the pump is accomplished in two ways:

- On the smaller frame motors, 7.5 through 30 HP, a plug-in power cord is furnished to allow easy changes of both voltage and cord length without motor entry.
- On the larger frame motors, 20 through 60 HP with much larger conductor sizes, the cord enters through a double gland arrangement to a terminal strip for conductor attachment.

# Mechanical Seals

Tandem mechanical seals are provided with silicon carbide seal faces on the pump end and carbon/ceramic at the motor end, both with Buna elastomers and stainless springs and retainers.

Optional silicon carbide and/or tungsten carbide faces are also available. These are readily available seals provided as spares either singly or in available seal repair kits, and are much more economical than proprietary cartridge arrangements.



The seals are lubricated by a large capacity oil-filled chamber and protected from water leakage into the chamber with a two-conductor probe that senses and alarms water entry well before any water can enter the motor housing.

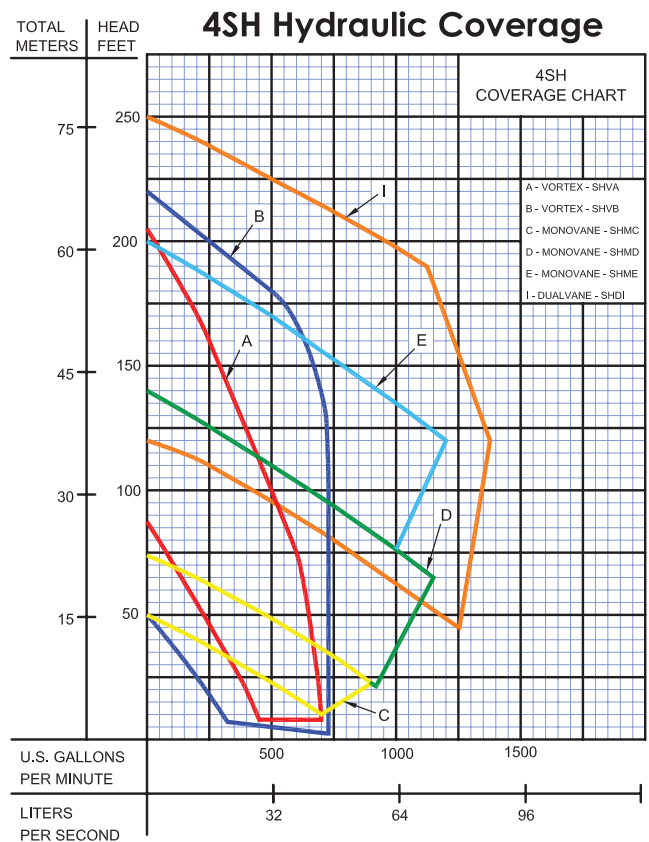

The pump design, with large shaft diameter and tapered impeller drive, minimizes shaft deflection and vibration to better maximize seal life.

## 50,000 Hour Bearings

SH Solids Handling pumps are fitted with a single row top and double row bottom bearing and oil lubricated for maximum life.

The bearings are rated for 50,000 hour life at 80 GPM, the flow rate corresponding to 2 ft/second in a 4 inch pipe.

## Coating System



The exterior of the pump is coated with two coats of DuPont Corlar® 2.1-ST high solids epoxy mastic system, based on the DuPont amido amine modified epoxy technology. The 10-12 mil DFT coating system is optimal for immersion service and proven in salt-spray accelerated life tests.

## Slotted Discharge

For maximum flexibility, the pump casing is provided with a slotted discharge to easily accommodate both 4" ANSI and 100 mm ISO flanges, facilitating the use of a variety of US and European slide adapters.

## Mounting Options

The SH pumps are normally mounted on a slide rail system with Break-Away Fitting or, with an available foot kit, in a floor mounted position.

## Break-Away Fittings & Accessories

Crane Pumps & Systems also provides Barnes brand accessories to complete the construction of a lift station or other installation.

Break-Away Fittings are available to facilitate easy installation or removal of pumps via a slide rail system. For permanent floor-mounted systems, pump foot kits are available to support the pump high enough to prevent clogging between the pump volute end the floor.

Control Panels are also available for simplex or multiple pump installations, customizable to meet you specification.

Other accessories include pit covers with access doors, lifting chains, pump hoists, level controls and check valves.

## Lead Times

The SH Solids Handling pump line is manufactured in a dedicated Lean Assembly Cell. Each pump is assembled, tested, painted and packaged within the cell, allowing a normal lead time of three weeks, with faster shipment available. Every SH Solids Handling pump is performance tested, and the resulting head-capacity curve is affixed to the Instructions and Operation Manual shipped with the pump.

DuPont logo \*Corlar is registered trademark of E.I du Pont de Nemours and Company





**CRANE** PUMPS & SYSTEMS

**motralec**

4 rue Lavoisier . ZA Lavoisier . 95223 HERBLAY CEDEX  
Tel. : 01.39.97.65.10 / Fax. : 01.39.97.68.48  
Demande de prix / e-mail : [service-commercial@motralec.com](mailto:service-commercial@motralec.com)  
[www.motralec.com](http://www.motralec.com)