

SEV₄₁₂

SUBMERSIBLE NON-CLOG PUMP

Barnes SEV pumps combine high quality, high performance and low cost in a rugged, heavy duty design. Capable of handling up to 2 inch spherical solids, the pump utilizes a vortex impeller and a combination of cast iron and stainless steel components to stand up to the toughest residential sewage ejector applications.

Outstanding Performance

- Maximum flow rate to 72gpm at 11' of head
- Maximum shutoff head of 25'
- Vortex impeller provides 2" solids handling capability
- Permanent split capacitor motor for reliable, high performance, longer motor life, greater starting torque, and lower amp draw
- 1/2hp 3450rpm single phase motor includes overload protection
- Heavy duty upper and lower ball bearings are oil lubricated for superior cooling and maximum life

Heavy Duty Materials of Construction

- Cast iron motor housing
- Cast iron pump body
- Cast iron multi-vane vortex impeller
- Stainless steel pump shaft
- Stainless steel hardware
- Buna-N O-rings

Level Control Options

- Manual operation, no control provided
- Wide angle mechanical float mounted on discharge pipe or pump body
- Snap action vertical float switch mounted on discharge pipe or pump body
- All switches utilize "piggy back" switches which eliminates the need to pull pump to check for switch failure.



motralec

4 rue Lavoisier . ZA Lavoisier . 95223 HERBLAY CEDEX
Tel. : 01.39.97.65.10 / Fax. : 01.39.97.68.48
Demande de prix / e-mail : service-commercial@motralec.com

www.motralec.com

CRANE PUMPS & SYSTEMS

Additional Pump Features

- CSA C/US listed
- 20' cord length standard
- 12 month limited warranty

Available Models

- SEV412
manual unit, no control provided
- SEV412A
furnished with mechanical float for pipe mount
- SEV412VF
furnished with vertical float for pipe mount
- SEV412AT
furnished with mechanical float tethered to pump
- SEV412VFT
furnished with vertical float mounted to pump

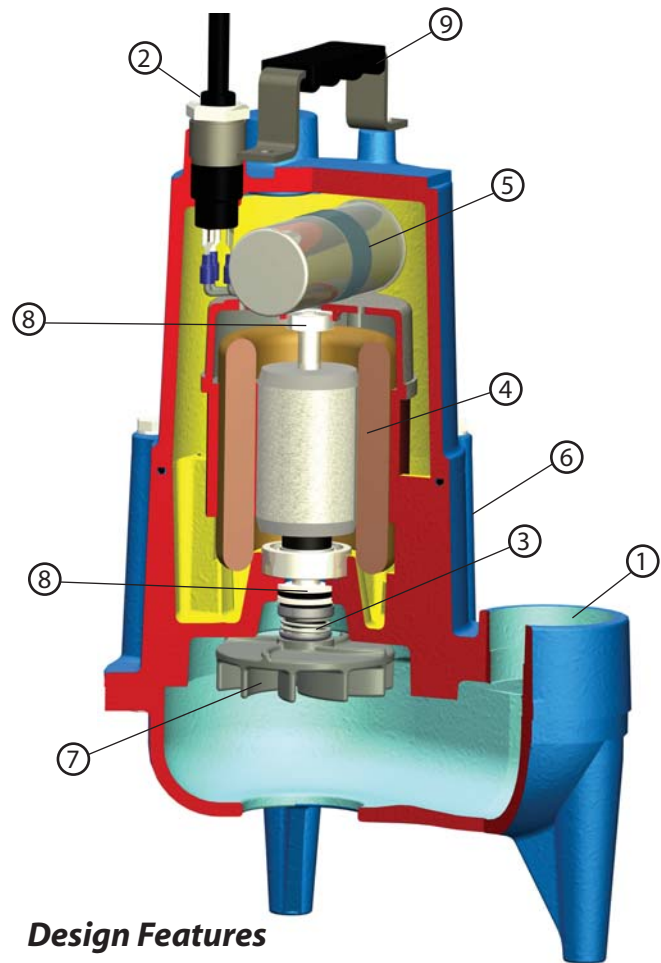

Design Features

1. 2" NPT outlet connection
2. Proven cord entry design prevents leakage
3. Heavy duty industrial Type 21 silicon carbide seal
4. 1/2 HP motor for efficient and reliable effluent pumping
5. Motor capacitor provides high start torque
6. Corrosion-resistant cast iron construction
7. Vortex impeller and generous casing volute easily pass up to 2 inch solids.
8. Oil-lubricated ball bearings provide maximum life
9. Stainless steel lifting handle with rubber grip

