

Packaged Sewage Systems

CONTRACTOR TOUGH

Key Design Features

- Minimize time on site
- Fast installation
- High quality robust construction
- Large capacity 41 gallon reservoir provides longer run times to extend pump life
- 24" deep model available for shallow digging
- Split cover for easy access



PITPRO™

**24 mo.
WARRANTY**

TYPICAL SEWAGE SYSTEM

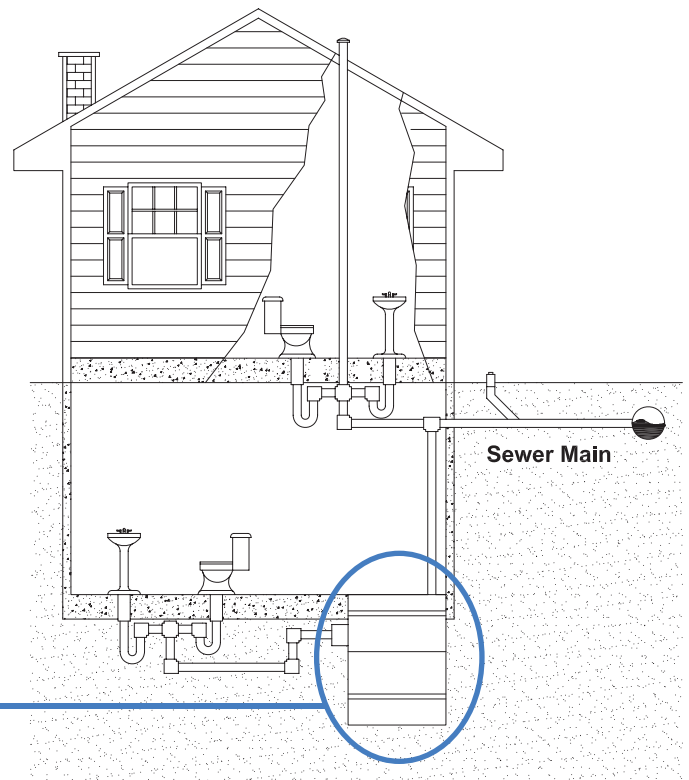

motralec

4 rue Lavoisier . ZA Lavoisier . 95223 HERBLAY CEDEX
Tel. : 01.39.97.65.10 / Fax. : 01.39.97.68.48
Demande de prix / e-mail : service-commercial@motralec.com

www.motralec.com

CRANE® PUMPS & SYSTEMS

Standard Line

30 Gallon Features

High strength,
one piece
polyethylene
tank

Flexible inlet flange

Choice of industrial
quality Barnes
Sewage pump

30 gallon
capacity
reservoir

Check valve
included at **no**
additional charge

Steel or Poly cover

Weep hole factory
drilled on all pipes
to prevent air locks

Mercury free
mechanical
piggyback float
level control

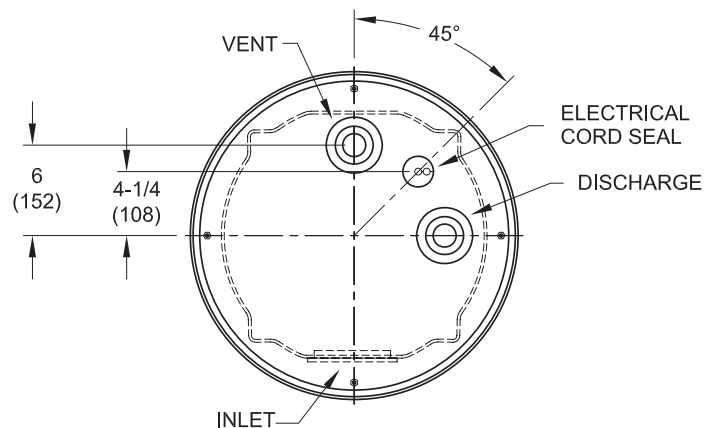
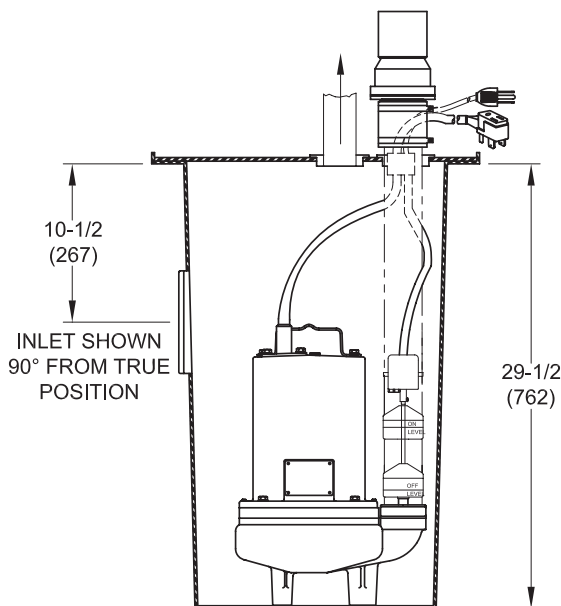
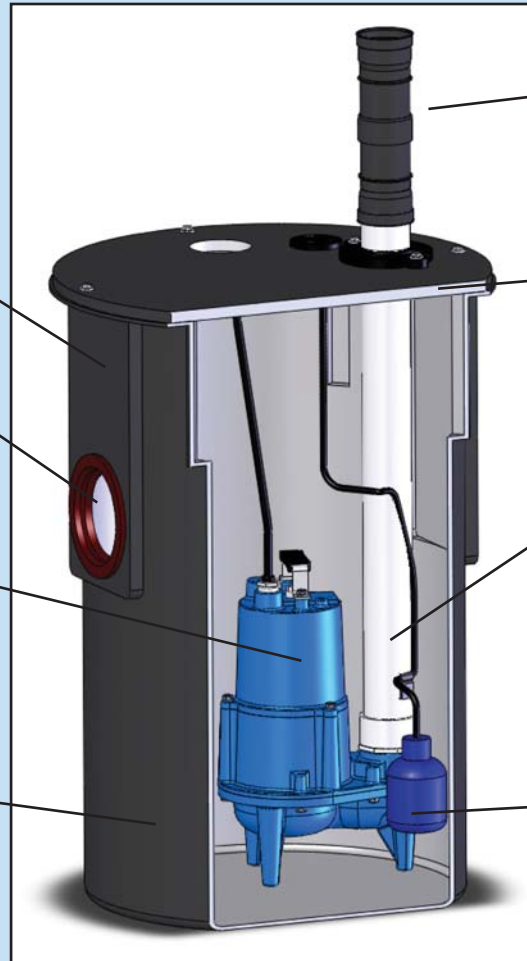

Premium Line

41 Gallon PitPro Features

PITPRO™

- Ultra tough structural poly-cover
- Level control to access control float without pump removal
- Easy to connect inlet. Using rubber style coupling (no penetrations to make)
- Easily adjustable mercury free mechanical float level control
- Universal ribbed floor to prevent pump movement, works with any pump
- Compression check valve at no additional charge
- Split cover allows pump access without disturbing vent pipe
- High strength one piece polyethylene tank
- Extra large 41 gallon capacity reservoir provides longer run time for increased pump life
- Choice of industrial quality Barnes Sewage pump
- Anti-Flotation ribs
- For structural integrity, large diameter short tank minimize digging time

Dimensions in inches (mm)

	SHORT	TALL
A	24 (610)	30 (762)
B	10 (254)	10 (254)
C	20½ (521)	20 (508)
D	25 (635)	21½ (546)
E	5⅝ (148)	5⅝ (148)
F	3¼ (83)	3¼ (83)
G	1⅝ (28)	1⅝ (28)
H	4⅜ (111)	4⅜ (111)

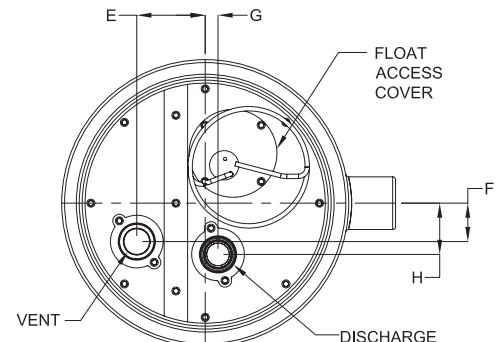
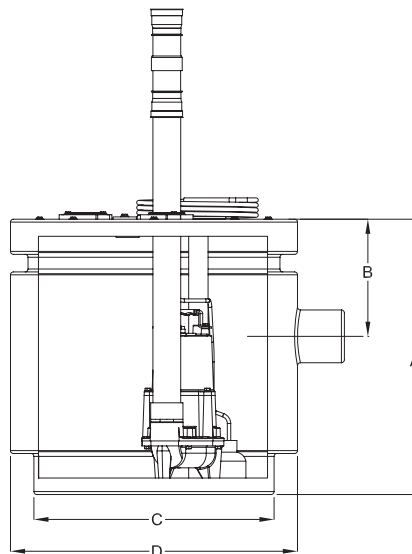

BARNES®

Professional Plumbing



SE51



SE411/
SE421



SEV412

Model	SE51	SE411	SE421	SEV412
Motor	1/2hp	4/10hp	4/10hp	1/2hp
RPM	1750	1750	1750	3450
Electrical	115v 1ph	115v 1ph	230v 1ph	115v 1ph
Cord Length	20'	15'	15'	20'
Construction	Cast Iron	Cast Iron	Cast Iron	Cast Iron
Impeller	Cast Iron	Cast Iron	Cast Iron	Cast Iron Vortex
Discharge	2"	2"	2"	2"
Solids	2"	2"	2"	2"
Max Head	25'	25'	25'	25'
Max Gallons/Minute	165'	120'	120'	70'

Control Panels • Indoor/Outdoor High Water Alarms



Barnes control panels provide proven, reliable performance and potential malfunction warning. Simplex and Duplex models are contained within a NEMA 4X enclosure and are available with single or three phase power. All components are UL listed.

A variety of remote alarms with warning lights and/or annunciators for indoor or outdoor use may be specified. 120v power supply required.

CRANE®

A Crane Co. Company

PUMPS & SYSTEMS

motralec

4 rue Lavoisier . ZA Lavoisier . 95223 HERBLAY CEDEX

Tel. : 01.39.97.65.10 / Fax. : 01.39.97.68.48

Demande de prix / e-mail : service-commercial@motralec.com

www.motralec.com

© Crane Pumps & Systems, Inc.
A Crane Co. Company
Printed in U.S.A.
BPPPKGSYS - Rev. A (8/10)