

Replacement Core Unit

200/2000 Series Basins

The reliability and longevity of centrifugal grinder pumps is now available in a replacement "core unit" package that fits directly into E/One® 200 and 2000 Series Basins.

The heart of any Grinder System is the Grinder Pump. The Barnes® Omni Grind Plus™ pump combines the reliability of a centrifugal grinder pump design with a high-head design that readily replaces existing progressive cavity grinder pumps. The Barnes® centrifugal grinder pump eliminates the continually-wearing rubber stator found in progressive cavity units.

- Fits directly into E/One 200 & 2000 Series Basins
- Utilizes proven Barnes® Centrifugal Grinder technology
- UL and CSA listed pump to assure quality and electrical safety
- Includes sealed pressure switch for level control and alarm circuitry
- "Goose-neck" outlet piping slides directly into Basin receiver
- Pump-mounted check and anti-siphon valves prevent reverse flow and isolate home from pressure main
- All cables and instructions provided to connect power cable from Barnes® grinder pump to existing plug

Additional Barnes® Grinder Pump Features

Superior Performance

- Barnes® 2HP OGP outperforms progressive cavity pumps in both capacity and life

Long Life

- Vortex impellers, silicon carbide mechanical seal, 100,000 hour L-10 bearings and oil-cooled motors provide reliable and trouble-free operation

Efficient

- Hydraulic performance superior to 1HP progressive cavity pumps with COMPARABLE POWER CONSUMPTION



U.S. Patent 7,357,341

*E/One is a registered trademark of Environment One Corporation

* Power and control cables normally coiled within basin.

motralec

4 rue Lavoisier . ZA Lavoisier . 95223 HERBLAY CEDEX
Tel. : 01.39.97.65.10 / Fax. : 01.39.97.68.48
Demande de prix / e-mail : service-commercial@motralec.com

www.motralec.com

CRANE PUMPS & SYSTEMS

Exclusive Slicerator™

The staggered slicing action of the grinder radial cutter dramatically reduces the torque requirement of the motor, cuts with less horsepower, and increases the unit's efficiency. Eliminates clogging with particularly troublesome objects such as plastic, rubber, sanitary napkins, disposable diapers, and cloth items.

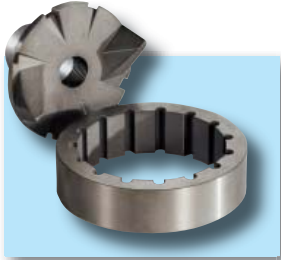

Barnes® Replacement Core Unit Features

1. Stainless discharge pipe fits into existing receiver
2. Flap-style check valve easily maintained
3. Grinder pump is cast iron and all hardware provided in corrosion-resistant stainless steel
4. Anti-siphon valve protects system from 'negative head' conditions
5. 2HP centrifugal grinder pump empties basin in half the time with substantially greater life than progressive cavity design
6. Two-stage design outperforms progressive cavity design
7. Exclusive slicerator grinding mechanism eliminates jams
8. Air bell for pump activation
9. Level control easily removed for inspection without removing pump
10. Independent air bell for alarm activation
11. Quick-connect fittings simplify electrical connection
12. ESPS™ sealed pressure switch controls pump with no exposed electrical components
13. Compensation diaphragm eliminates need for relief tubes or bulky bladders
14. Stainless steel mounting plate fits directly into 200/2000 series basins
15. Lifting eyes simplify handling.

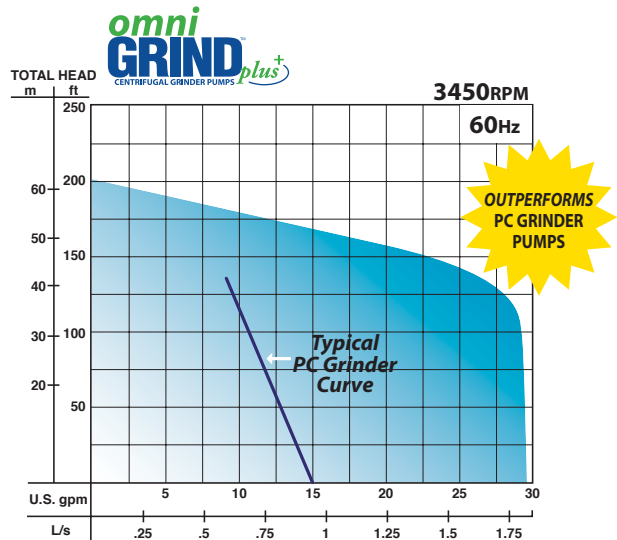
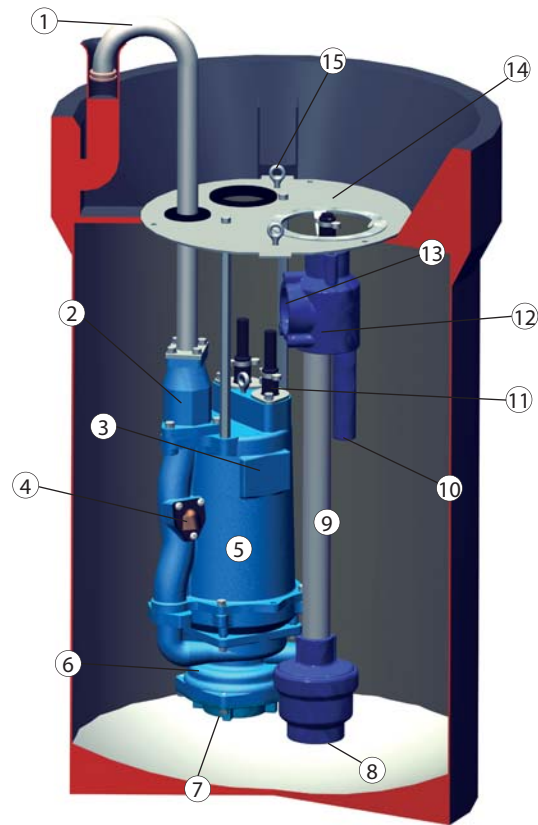

CRANE PUMPS & SYSTEMS