

AutoBlend Systems Spirits Production

Advantages

- Continuous production enables sterile operation.
- High capacity.
- High security, can be run unattended.
- Constant product quality.
- Several different products can be produced with on system.
- Direct connection to the filling station.



The primary requirement to alcoholic drink blending is to maintain the required alcohol content in the final product by mixing the high percentage distillate (up to 96% alcohol) with water.

This installation achieves an accuracy of ± 0.03 vol.% alcohol. It uses a control loop consisting of a density analyzer, a controller and a water-addition pump with automatic delivery volume adjustment.

Depending on the product type, small volumes of other extracts may be added to influence the taste and color. A second control loop using a colorimeter can be used to control the amount of the addition and thereby the final product color.

Simplified process diagram

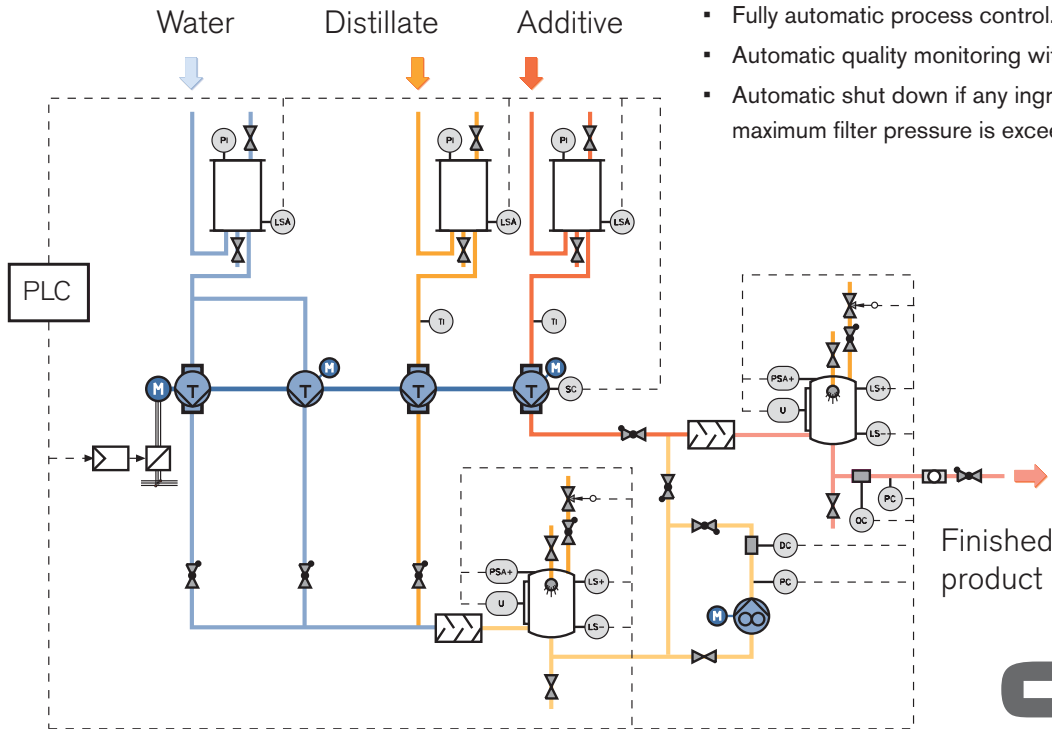

Components

- 2 vertically combined metering pumps Type C with electrical and manual discharge volume adjustment, 4 plunger heads (3 double-acting).
- 3 air vessels.
- 2 buffer vessels.
- Online colorimeter and density meter.
- Various pressure and level switches.
- 2 static mixers.
- Variable-speed drive motor with frequency converter.
- Various pressure and level switches.

Automation

- Fully automatic process control.
- Automatic quality monitoring with control loops.
- Automatic shut down if any ingredient runs out or if maximum filter pressure is exceeded.

SPX
WHERE IDEAS MEET INDUSTRY

Your local contact:

motralec

4 rue Lavoisier . ZA Lavoisier . 95223 HERBLAY CEDEX
Tel. : 01.39.97.65.10 / Fax. : 01.39.97.68.48
Demande de prix / e-mail : service-commercial@motralec.com
www.motralec.com