

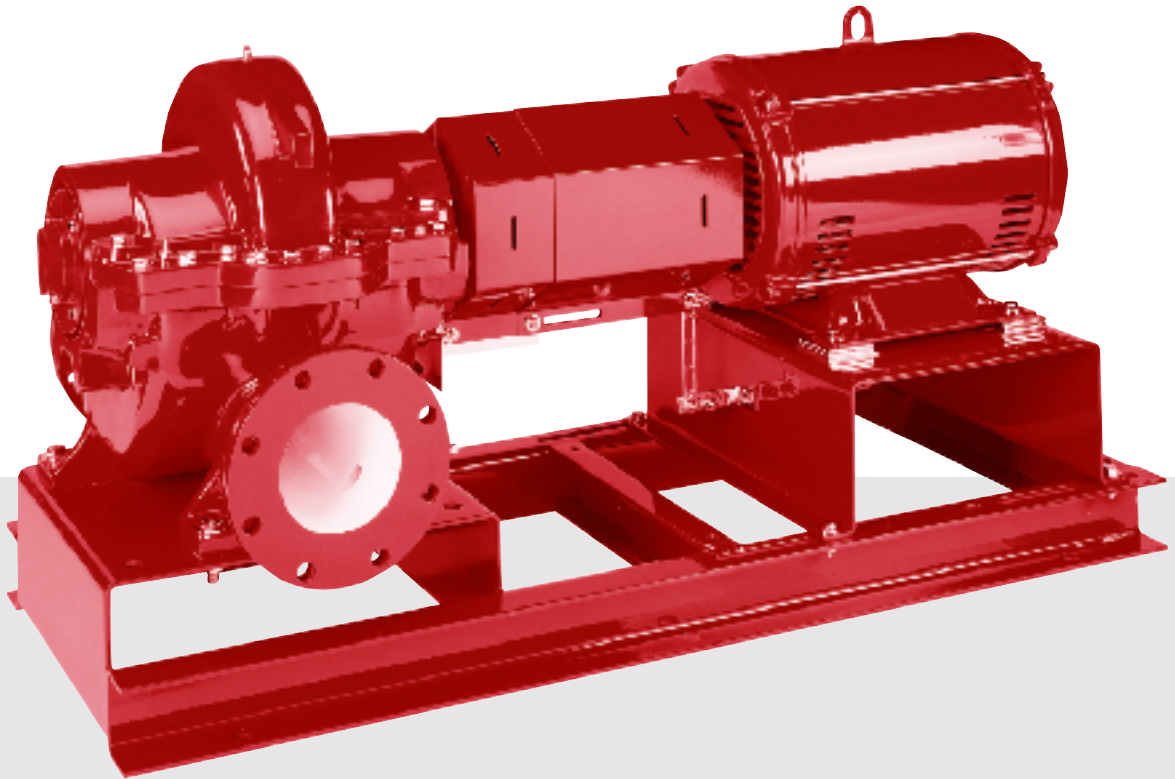

B-520A

Series HSC³ Split Case Pumps

Technical Bulletin



Bell & Gossett



ITT Industries

Engineered for life

motralec

4 rue Lavoisier . ZA Lavoisier . 95223 HERBLAY CEDEX

Tel. : 01.39.97.65.10 / Fax. : 01.39.97.68.48

Demande de prix / e-mail : service-commercial@motralec.com

www.motralec.com

Table of Contents

Useful Pump Formulas	2
Performance Curves	3
Materials of Construction (Standard)	4
Materials of Construction (Optional)	5
L/D Ratio Comparison	5
Dimensions	6-7
Typical Specifications	8

Useful Pump Formulas

Pressure (PSI)	=	$\frac{\text{Head (Feet)} \times \text{Specific Gravity}}{2.31}$
Head (Feet)	=	$\frac{\text{Pressure (PSI)} \times 2.31}{\text{Specific Gravity}}$
Vacuum (Inches of Mercury)	=	Dynamic Suction Lift (Feet) x .883 x Specific Gravity
Horsepower (Brake)	=	$\frac{\text{GPM} \times \text{Head (Feet)} \times \text{Specific Gravity}}{3960 \times \text{Pump Efficiency}}$
Horsepower (Water)	=	$\frac{\text{GPM} \times \text{Head (Feet)} \times \text{Specific Gravity}}{3960}$
Efficiency (Pump)	=	$\frac{\text{Horsepower (Water)}}{\text{Horsepower (Brake)}} \times 100 \text{ Per Cent}$
NPSH (Available)	=	Positive Factors – Negative Factors

Affinity Laws: Effect of change of speed or impeller diameter on centrifugal pumps.

	GPM Capacity	Ft. Head	BHP
Impeller Diameter Change	$Q_2 = \frac{D_2}{D_1} Q_1$	$H_2 = \left(\frac{D_2}{D_1}\right)^2 H_1$	$P_2 = \left(\frac{D_2}{D_1}\right)^3 P_1$
Speed Change	$Q_2 = \frac{RPM_2}{RPM_1} Q_1$	$H_2 = \left(\frac{RPM_2}{RPM_1}\right)^2 H_1$	$P_2 = \left(\frac{RPM_2}{RPM_1}\right)^3 P_1$

Where Q = GPM, H = Head, P = BHP, D = Impeller Dia., RPM = Pump Speed

Performance Curves – Series HSC³

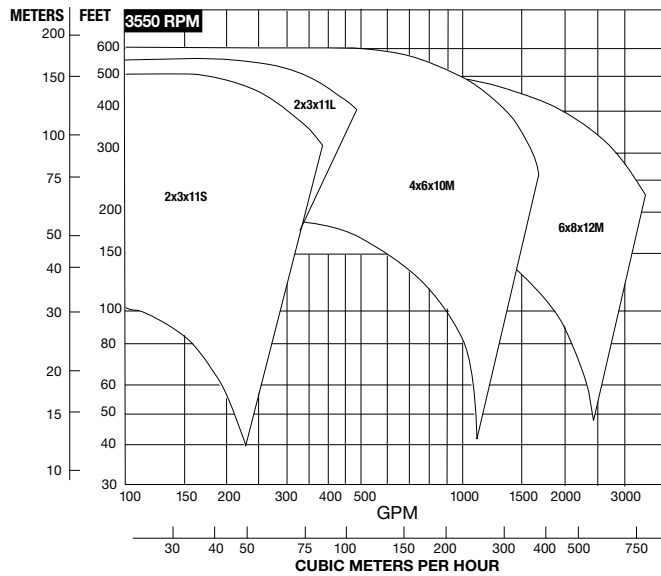
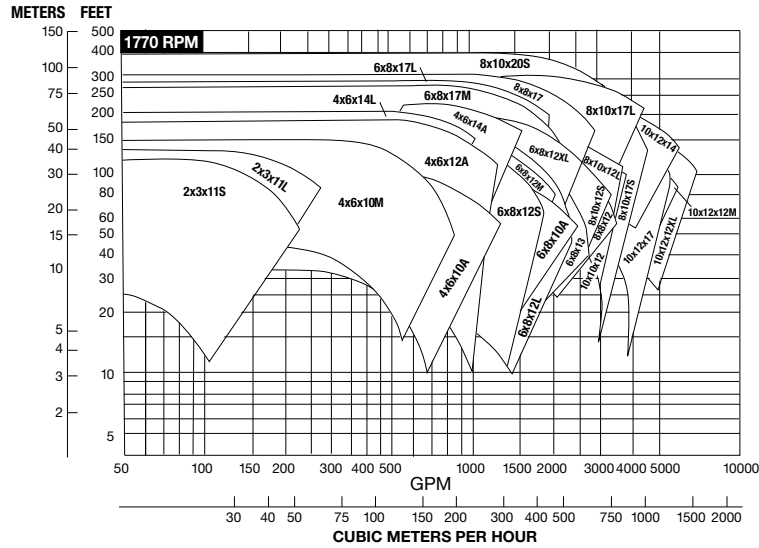
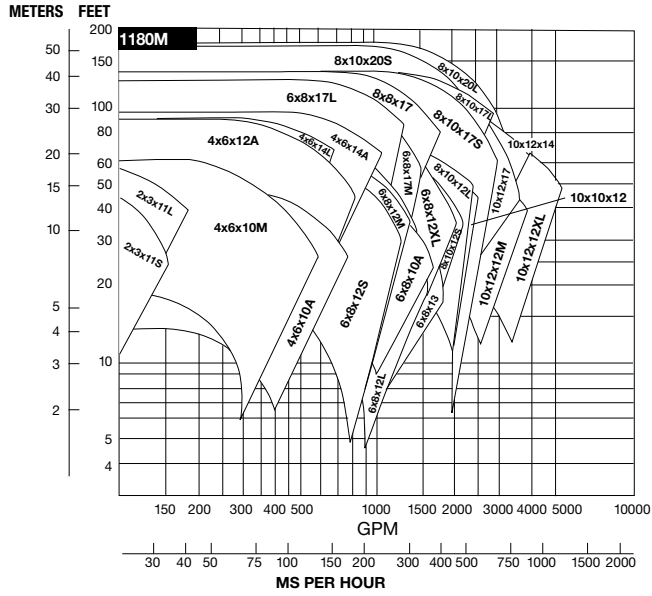

Series HSC³ Materials of Construction

Mechanical Seals Mounted on Shaft

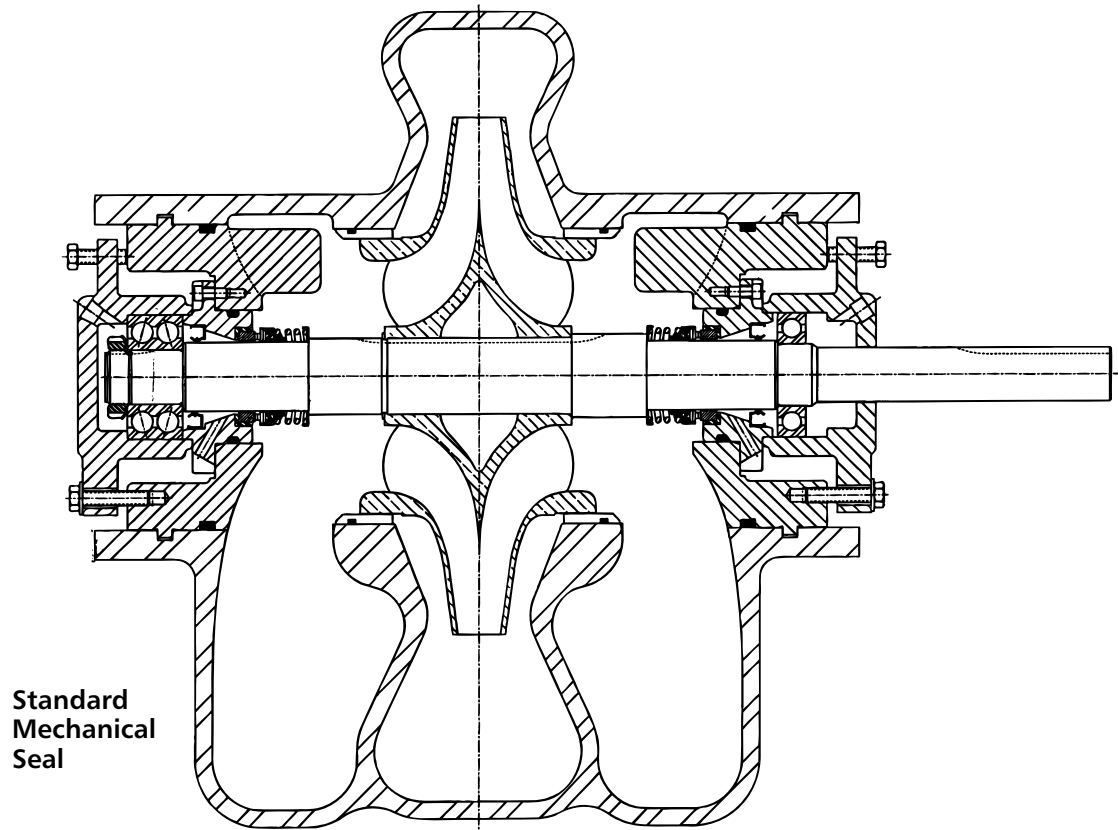

**Standard
Mechanical
Seal**

PART NAME	MATERIAL
	Cast Iron, Bronze Fitted
Casing Assembly	Cast Iron (ASTM A48 Class 35A)
Casing Joint Gasket (Suction)	Paper (Vellumoid 505)
Casing Joint Gasket (Discharge)	Paper (Vellumoid 505)
Casing Ring	Bronze (ASTM B584-932)
Shaft	416 Stn. Stl.
Bearing Housing	Cast Iron (ASTM A48 Class 30A)
Bearing Housing	Cast Iron (ASTM A48 Class 30A)
Bearing (Inboard) Ball	Steel
Bearing (Outboard) Ball	Steel
Stuffing Box (Mechanical Seal)	Cast Iron (ASTM A48 Class 30A)
Lip Seal (Bearing)	Rubber (BUNA "N")
Mechanical Seal	Stn. Stl., Rubber, Carbon, Ceramic
Capscrew (Bearing Housing)	Steel, Grade 2
Pipe Plugs (Bearing Housing)	Steel
Key, Impeller	Stn., Stl. (ANSI 416)
Key, Coupling	Steel
"O" Ring (Casing Ring)	Rubber (Buna "N")
"O" Ring (Cover Plate)	Rubber (Buna "N")
Retaining Ring (Impeller)	Steel
Ring Retaining (Bearing)	Steel
End Cap	Steel
Spirol Pin (Casing Ring)	304 SS
Impeller	Bronze (ASTM B584-875)

Mechanical Seal Data

Standard Construction:

- 175 PSIG (12 BAR) Maximum Working Pressure
 - *100 PSIG (7 BAR) Maximum Suction Pressure
125#FF ANSI FLANGE (ANSI A21.10, AWWA C110 & ANSI B16.1 class 125)
 - Type 21, Buna/Carbon-Ceramic, *100 psig (7 bar) maximum suction pressure, from -20 to 225°F (-29 to 107°)
 - Optional Seals:
Type 21, EPR/Carbon-Ceramic, *100 psig (7 bar) maximum suction pressure, from -20 to 250°F (-29 to 121°C)
Type 21, EPR/Carbon-Tungsten Carbide, *100 psig (7 bar) maximum suction pressure, from -20 to 250°F (-29 to 121°C)
- *Maximum suction pressure for 3500 RPM is 85 psig (6 bar).

Internally Self-Flushing Seal:

The HSC³ features internally self-flushing mechanical seals. This innovative design, an industry standard, insures maximum seal life lubrication, heat dissipation and debris removal – all without vulnerable, external flush lines and filter kits that can clog and

result in seal failure. With the Bell & Gossett internally self-flushing seal design, as much as 25% of the total pump flow continuously flushes the seal faces compared to only a few GPM for conventional stuffing box mounted mechanical seals. Seals remain cooler and unwanted debris is flushed away from the mechanical seal faces resulting in longer mechanical seal life.

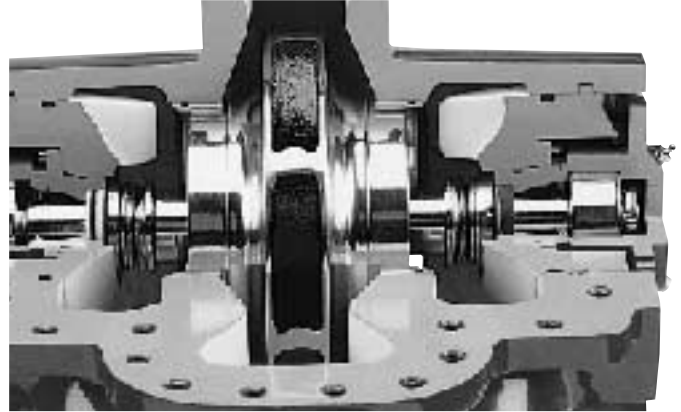

L/D Ratio Comparison

The L/D ratio measures the comparable shaft stiffness factor between two pumps where “L” equals the distance between the inboard and outboard bearings and “D” represents the shaft diameter at the impeller. The lower the ratio, the stiffer the shaft. Excessive shaft deflection will shorten mechanical seal life, sub-

ject the shaft to fatigue stress, that could result in shaft failure and increase the bearing load with a corresponding reduction in bearing life. As calculated in the table below, the HSC³ has a L/D ratio that is significantly below a traditional horizontal split case pump.

PUMP SIZE	SERIES HSC ³			TYPICAL HORIZONTAL SPLIT CASE PUMPS		
	L= SPAN BETWEEN BEARING TO BEARING (CENTER)	D= DIAMETER THROUGH IMPELLER	L/D	L= SPAN BETWEEN BEARING TO BEARING (CENTER)	D= DIAMETER THROUGH IMPELLER	L/D
2x3x11S	11.03	1.689	6.5	20.90	1.689	12.4
2x3x11L	11.03	1.689	6.5	20.90	1.689	12.4
4x6x10A	14.56	1.939	7.5	25.25	1.939	13.0
4x6x12A	12.53	1.689	7.4	22.90	1.689	13.6
4x6x14A	12.53	1.689	7.4	22.90	1.989	13.0
6x8x10A	18.25	1.939	9.4	29.57	2.439	12.1
6x8x12S	12.53	1.689	7.4	22.90	1.689	13.6
6x8x12M	14.56	1.939	7.5	25.25	1.939	13.0
6x8x12L	12.53	1.689	7.4	22.90	1.689	13.6
6x8x12XL	12.53	1.689	7.4	22.90	1.689	13.6
6x8x13	16.16	1.939	8.3	27.25	1.939	14.1
6x8x17M	16.16	1.939	8.3	27.25	1.939	14.1
6x8x17L	16.16	1.939	8.3	27.25	1.939	14.1
8x8x12	16.16	1.939	8.3	27.25	1.939	14.1
8x8x17	18.59	2.439	7.6	29.90	2.439	12.3
8x10x12S	18.59	2.439	7.6	29.90	2.439	12.3
8x10x12L	18.59	2.439	7.6	29.90	2.439	12.3
8x10x17S	18.59	2.439	7.6	29.90	2.439	12.3
8x10x17L	18.59	2.439	7.6	29.90	2.439	12.3
8x10x20S	18.59	2.439	7.6	29.90	2.439	12.3
8x10x20L	18.59	2.439	7.6	29.90	2.439	12.3
10x10x12	21.59	2.439	8.9	32.90	2.439	13.5
10x12x12M	21.59	2.439	8.9	32.90	2.439	13.5
10x12x12XL	21.59	2.439	8.9	32.90	2.439	13.5
10x12x14	18.59	2.439	7.6	29.90	2.439	12.3
10x12x17	18.59	2.439	7.6	29.90	2.439	12.3

Series HSC³ Model – 150 Dimensions

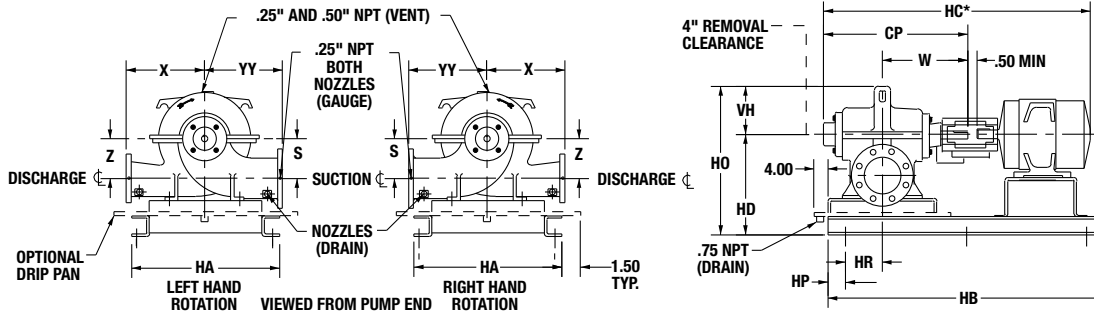

STANDARD: 125# FF ANSI FLANGE (ANSI A21.10, AWWA C110 & ANSI B16.1 class 125)

PUMP SIZE	MOTOR FRAME	DIMENSIONS – INCHES (MM)													
		HA	HB	HP	HR	CP	HC* MAX	HD	HO	S & Z	VH	VH1	W	X	YY
2x3x11 S, L	143-215	20.00	44.00 (1118)	6.00	2.25	18.62	39 (991)	15.25 (388)	22.05 (560)	5.50 (140)	6.80 (173)	-	11.31 (287)	9.00 (229)	10.00 (254)
	254-365	(508)	54.00 (1372)	(152)	(57)	(473)	50 (1270)								
4x6x10A	182-215	21.50	48.00 (1219)	6.00	2.88	19.93	50 (1270)	18.25 (464)	25.94 (659)	7.00 (178)	7.69 (195)	-	12.19 (310)	11.50 (292)	12.00 (305)
	254-324	(546)	54.00 (1372)	(152)	(73)	(506)	59 (1499)								
4x6x10M	182-215	24.00	48.00 (1219)	6.00	4.62	22.81	43 (1092)	18.25 (464)	26.12 (664)	6.50 (165)	7.88 (200)	-	13.50 (343)	11.50 (292)	13.00 (330)
	254-326		58.00 (1473)				52 (1321)								
	364-405		64.00 (1626)				61 (1549)								
	444-445		76.00 (1930)				68 (1727)								
4x6x12A	215	24.00	48.00 (1219)	6.00	4.62	22.81	43 (1092)	18.25 (464)	26.81 (681)	738 (188)	8.56 (218)	-	13.50 (343)	11.50 (292)	13.00 (330)
	254-326		58.00 (1473)				52 (1321)								
	364-365		64.00 (1626)				61 (1549)								
4x6x14A	215-256	24.00	48.00 (1219)	6.00	3.25	20.62	45 (1143)	19.52 (489)	28.50 (723)	7.75 (197)	9.20 (234)	-	12.56 (319)	11.50 (292)	13.00 (330)
	284-365		58.00 (1473)				54 (1372)								
	404-405		68.00 (1727)				60 (1524)								
	444		76.00 (1930)				64 (1625)								
4x6x14L	182-256	24.00	48.00 (1219)	6.00	3.25	20.62	45 (1143)	19.25 (489)	28.87 (733)	7.75 (197)	9.62 (244)	-	12.56 (319)	11.50 (292)	13.00 (330)
	284-365	(610)	58.00 (1473)	(152)	(83)	(524)	54 (1372)								
6x8x10A	215-286	24.00	58.00 (1473)	6.00	10.75	29.19	56.38 (1432)	21.25 (540)	30.50 (775)	8.25 (210)	9.25 (235)	-	17.58 (447)	12.50 (328)	12.50 (318)
	324-326		64.00 (1626)				58.38 (1438)								
	364-365		68.00 (1727)				60.38 (1534)								
6x8x12 S, L, XL	182-256	21.50	48.00 (1219)	6.00	3.25	20.62	45 (1143)	21.25 (540)	28.75 (730)	9.00 (229)	9.60 (244)	-	12.56 (319)	14.00 (356)	14.00 (356)
	284-326		54.00 (1372)				51 (1295)								
	364-365		60.00 (1524)				54 (1372)								
6x8x12M	254-326	24.00	58.00 (1473)	6.00	4.63	22.81	53 (1346)	21.25 (540)	30.85 (784)	9.00 (229)	9.60 (244)	-	13.50 (343)	14.00 (356)	14.00 (356)
	364-405		64.00 (1626)				61 (1549)								
	444-447		76.00 (1930)				71 (1803)								
6x8x13	254-326	24.00	62.00 (1575)	6.00	5.63	26.19	56 (1422)	20.00 (508)	29.40 (747)	8.00 (203)	9.40 (239)	-	16.06 (408)	13.00 (330)	15.50 (394)
	364-405	(610)	68.00 (1727)	(152)	(143)	(665)	65 (1651)								
6x8x17 M, L	284-326	24.00	62.00 (1575)	6.00	5.63	26.19	56 (1442)	21.25 (540)	33.00 (838)	9.00 (229)	11.75 (299)	-	16.06 (408)	14.00 (356)	16.00 (406)
	364-405		68.00 (1727)				65 (1651)								
	444-445		76.00 (1930)				71 (1803)								
8x8x12	254-326	24.00	62.00 (1575)	6.00	5.63	26.19	56 (1422)	20.00 (508)	30.25 (768)	8.00 (203)	10.25 (260)	-	16.06 (408)	14.00 (356)	16.50 (419)
	364-405	(610)	68.00 (1727)	(152)	(143)	(665)	65 (1651)								
8x8x17	324-365	24.00	66.00 (1676)	6.00	7.00	28.94	62 (1575)	21.75 (553)	33.75 (857)	9.50 (241)	12.00 (305)	-	17.56 (446)	15.00 (381)	16.50 (419)
	404-445		76.00 (1930)				74 (1880)								
	447-449		86.00 (2184)				82 (2083)								
8x10x12 S, L	254-286	24.00	62.00 (1575)	6.00	7.00	28.94	56 (1422)	21.50 (546)	32.00 (813)	8.50 (216)	10.50 (267)	-	17.56 (446)	14.00 (356)	17.00 (432)
	324-365		66.00 (1676)				62 (1575)								
	404-445		76.00 (1930)				74 (1880)								
8x10x17 S, L	324-365	24.00	66.00 (1676)	6.00	7.00	28.94	62 (1575)	23.25 (591)	36.06 (916)	10.00 (254)	12.81 (325)	-	17.56 (446)	16.00 (406)	18.00 (457)
	404-445		76.00 (1930)				74 (1880)								
	447-449		86.00 (2184)				82 (2083)								
8x10x20 S, L	324-365	26.00	66.00 (1676)	6.00	7.00	28.94	62 (1575)	27.25 (692)	49.50 (1257)	14.00 (356)	15.44 (392)	22.25 (565)	17.56 (446)	18.00 (457)	20.00 (508)
	404-445		76.00 (1930)				74 (1880)								
	447-449		86.00 (2184)				82 (2083)								
10x10x12	284-365	24.00	68.00 (1727)	6.00	8.50	31.94	68 (1727)	22.50 (572)	33.69 (856)	9.00 (229)	11.19 (284)	-	19.06 (484)	16.00 (406)	18.00 (457)
	404-445	(610)	80.00 (2032)	(152)	(216)	(811)	81 (2057)								
10x12x12 M, XL	284-365	24.00	68.00 (1727)	6.00	8.50	31.94	68 (1727)	24.50 (622)	36.00 (914)	10.00 (254)	11.50 (292)	-	19.06 (484)	16.00 (406)	19.00 (483)
	404-445	(610)	80.00 (2032)	(152)	(216)	(811)	81 (2057)								
10x12x14	324-365	24.00	66.00 (1676)	6.00	7.00	28.94	62 (1575)	25.25 (641)	38.69 (983)	11.00 (280)	13.44 (341)	-	17.56 (446)	18.00 (457)	20.00 (508)
	404-445		76.00 (1930)				74 (1880)								
	447-449		86.00 (2184)				82 (2083)								
10x12x17	324-365	24.00	66.00 (1676)	6.00	7.00	28.94	62 (1575)	25.25 (641)	38.69 (983)	11.00 (280)	13.44 (341)	-	17.56 (446)	18.00 (457)	20.00 (508)
	404-445		76.00 (1930)				74 (1880)								
	447-449		86.00 (2184)				82 (2083)								

Not for construction unless certified.

Bell & Gossett Engineering Specification for Series HSC³ Base Mounted Double-Suction Pumps

DOUBLE SUCTION, HORIZONTAL SPLIT CASE PUMPS (BASE MOUNTED):

A. Manufacturer:

Contractor shall furnish and install new double suction horizontal split case pumps for chilled water and hot water heating systems as indicated on the drawings. Pumps shall be model HSC or HSCS as manufactured by **Bell & Gossett** under base bid. Equivalent units as manufactured by Taco or Armstrong may be submitted as deduct alternates. Pumps shall meet types, sizes, capacities, and characteristics as scheduled on the Equipment Schedule drawings.

B. Double Suction Horizontal Split Case Pump (Base Mounted):

1. The pumps shall be long coupled, base mounted, single stage, double suction, horizontally split case design, in cast iron bronze fitted construction specifically designed and guaranteed for quiet operation. Suitable standard operations at 225°F and 175 psig working pressure. Working pressures shall not be de-rated at temperatures up to 250°F. The pump internals shall be capable of being serviced without disturbing the upper casing half and system piping.
2. A bearing housing shall supply support for a pair of heavy-duty regreaseable ball bearings. An inboard single row bearing will absorb thermal expansive forces while an outboard double row bearing will be clamped in place to absorb both radial and thrust loads and keep the rotating element in proper axial alignment. Bearings shall be replaceable without disturbing the system piping, the upper casing half, and shall be regreaseable without removal of the bearings from the bearing housing.
3. The impeller shaft shall be a solid 416 stainless steel shaft.
4. Pump shall be equipped with a pair of internally flushed mechanical seal assemblies in direct contact with the pump shaft. Seal assemblies shall be Type 21 having a stainless steel housing, Buna bellows and seat gasket, stainless steel spring, and be of a carbon-ceramic design with the carbon face rotating against a stationary ceramic face.
5. Impeller shall be of the enclosed double suction type made of bronze, both hydraulically and dynamically balanced to ANSI/HI 1.1-1.5-1994, section 1.4.6.1.3.1, figure 1.106, balance grade G6.3 keyed to the shaft and fixed in the axial position.
6. A flexible type coupling, capable of absorbing torsional vibration, shall be employed between the pump and motor. On variable speed applications the coupler sleeve should be constructed of an EPDM material to maximize performance life.
7. The coupling shall be shielded by a dual rated ANSI B15.1, Section 8 AND OSHA 1910.219 compliant coupling guard and contain viewing windows for inspection of the coupling.
8. Pump volute shall be of a cast iron (rated for 175psig Max WP) axially-split design with flanges (175 psig drilled for 125# ANSI

companion flanges) and mounting feet integral cast into the bottom half of the casing. Suction and discharge flanges shall be on a common centerline in both the horizontal and vertical planes, and the volute shall include Bronze Casing Wear Rings, priming port, gauge ports at nozzles, and vent and drain ports. The upper half casing shall be capable of being removed without disturbing piping connections or electrical motor connections.

9. Pump seal flushing shall be internal within the pump casing and shall flush the seal at a rate equal to 25% of the total pump flow.
 10. Motors shall meet scheduled horsepower, speed, voltage, and enclosure design. Pump and motors shall be factory aligned, and shall be realigned after installation by the manufacturer's representative. Motors shall be non-overloading at any point on the pump curve and shall meet NEMA specifications and conform to the standards outlined in EPACT 92.
 11. Base plate shall be of structural steel or fabricated steel channel with fully enclosed sides and ends, and securely welded cross members. The grouting area shall be fully open. The combined pump and motor base plate shall be sufficiently stiff as to limit the susceptibility of vibration. The minimum base plate stiffness shall conform to ANSI/HI 1.3.4-1997 for *Horizontal Baseplate Design* standards.
 12. Base shall be capable of being field grouting.
 13. Pump rotation shall be righthand or lefthand as viewed from the pump end.
 14. Pump manufacturer shall be ISO-9001 certified.
 15. The seismic capability of the pump shall allow it to withstand a horizontal load of 0.5g, excluding piping and/or fasteners used to anchor the pump to mounting pads or to the floor, without adversely affecting pump operation.
 16. Each pump shall be factory hydrostatically tested per Hydraulic Institute standards and name-plated before shipment. It shall then be thoroughly cleaned and painted with at least one coat of high-grade paint prior to shipment.
- ### C. Accessories:
1. Where noted on schedule pumps shall be provided with internal bronze pump wear rings, special shaft materials, or special spacer couplers.
 2. Where noted on schedule either balanced or unbalanced seals of EPR Carbon/Ceramic seals, EPR Tungsten/Carbide seal, or packing gland material should be used in lieu of the standard seal.
 3. Where noted on schedule pumping equipment may require one or all of the following tests: Certified Lab tests (unwitnessed), Hydraulic Institute Level B tests, or Witnessed Tests.

motralec

4 rue Lavoisier . ZA Lavoisier . 95223 HERBLAY CEDEX

Tel. : 01.39.97.65.10 / Fax. : 01.39.97.68.48

Demande de prix / e-mail : service-commercial@motralec.com

www.motralec.com



Bell & Gossett



**ISO 9001
Certified**