

DVT3.60 — 3.140 Series

100% OIL-LESS COMBINATION PRESSURE / VACUUM PUMPS

Becker proudly introduces the next generation of 100% oil-less combination pressure/vacuum pumps for the graphic arts industry—the DVT 3.000 series.

DVT pumps are standard equipment on many OEM products, and are ideal for replacement of virtually any other brand—even oil-lubricated pumps. All our DVT pumps are *totally oil-less*. There is never any oil in the blast air to contaminate your product.



These pumps have improved cooling systems to ensure that they survive applications that would destroy ordinary pumps. These pumps operate cooler than the previous version. In addition, a built-in aftercooler produces cooler discharge air, which minimizes static electricity build-up.

Built-in *oversized* inlet filters for both the primary and second suction remove dust and dirt present around the pressroom equipment. A large discharge filter removes all carbon dust from the blast air so that there is no contamination of printed material.

The DVT series pumps are designed with convenience and minimum maintenance in mind. All regulating valves and all filters are on the *same* side of the pump. The inlet filters and the discharge filter housing are revealed by removing a cover plate with several large knobs. Checking or changing the vanes is a simple operation that takes only a few minutes.

Becker designed these pumps for the toughest applications on the most modern printing presses and bindery equipment. Not only has their ruggedness been improved, but, we also succeeded in designing pumps that are more efficient. Each model provides the same flow as its predecessor, but with less power consumption.

DVT pumps provide plenty of blast air and suction, and are supplied with regulating valves for both as standard equipment.

NO OIL

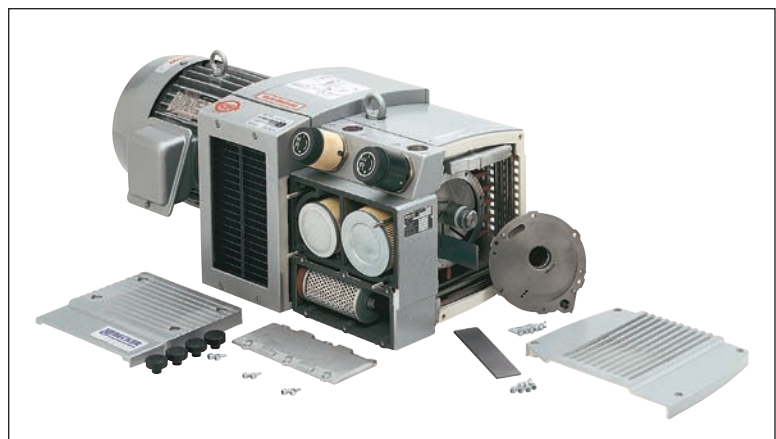

Becker DVT pumps have easy access to the oversized suction and blast filters. Checking and changing vanes takes only a few minutes.

motralec

4 rue Lavoisier . ZA Lavoisier . 95223 HERBLAY CEDEX
Tel. : 01.39.97.65.10 / Fax. : 01.39.97.68.48
Demande de prix / e-mail : service-commercial@motralec.com

www.motralec.com

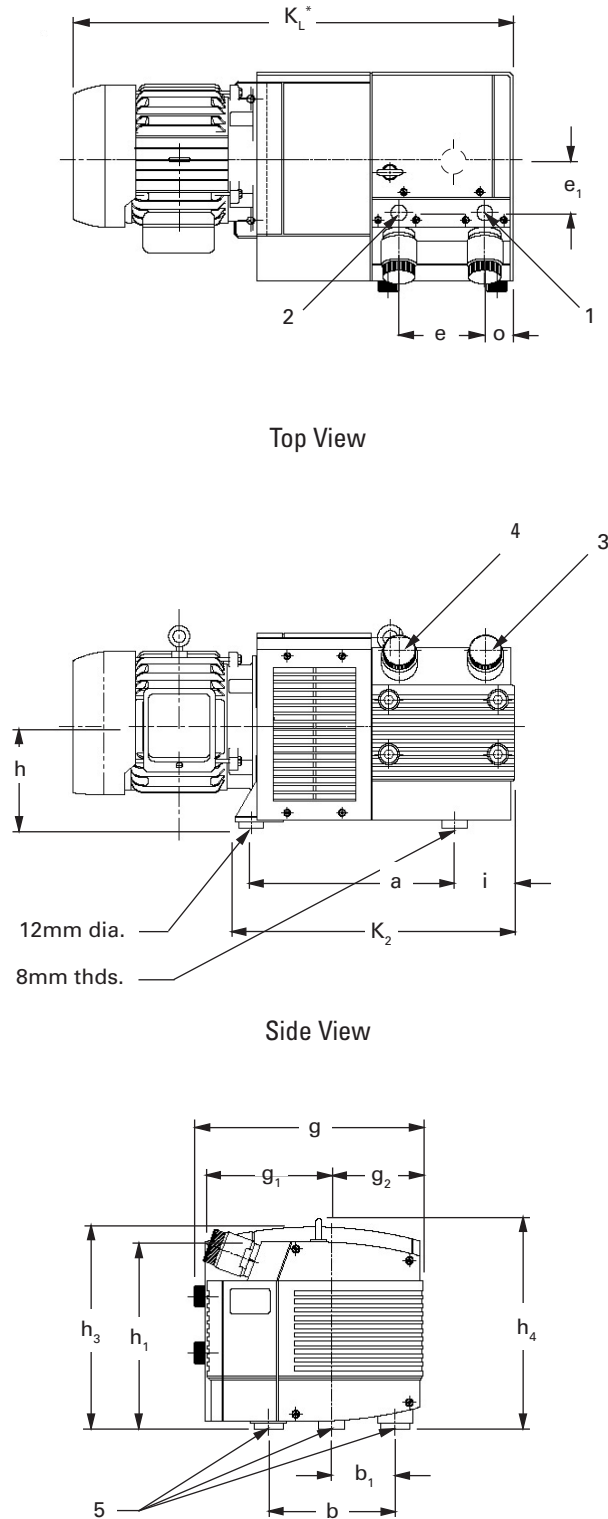
TECHNICAL DATA

Top View

Side View

End View (Opposite Motor End)

All data based on 60 Hz operation

	DVT 3.60	DVT 3.80	DVT 3.100	DVT 3.140	
Horsepower	5	5	7½	10	
Speed (RPM)	1740	1740	1740	1740	
Max. Press./Vac. (PSIG/in Hg)	9/18	9/18	9/18	9/18	
Max. Flow (CFM)	39	48	69	95	
Weight (lbs.)—w/o motor	104	108	156	172	
Weight (lbs.)—w/ motor*	175	240	306	392	
Noise Level (Max. dBA)	76	77	78	79	
Inlet Size, (BSP, in.)	1	1	1½	1½	
Discharge Size (BSP, in.)	1	1	1½	1½	
Dimensional Data	(Inches)				
	a	12.83	12.83	15.67	15.67
	b	7.5	7.5	9.65	9.65
	b ₁	3.75	3.75	4.82	4.82
	e	5.43	5.43	7.5	7.5
	e ₁	2.56	2.56	3.75	3.75
	g	13.9	13.9	18.5	18.5
	g ₁	7.68	7.68	8.78	8.78
	g ₂	5.55	5.55	9.06	9.06
	h	6.38	6.38	6.38	6.38
	h ₃	12.28	12.28	13.0	13.0
	h ₄	12.9	12.9	13.25	13.25
	i	3.78	3.78	5.5	5.5
	k ₂	17.64	17.64	22.17	22.17
k _L *	28.2	30	34.15	36.6	
o	1.81	1.81	2.36	2.36	

* May vary with motor type and manufacturer
 Manufacturer reserves right to alter data without notice.

- 1 - Suction Port, Main
- 2 - Blast Port
- 3 - Suction Regulating Valve, Main
- 4 - Blast Regulating Valve / Silencer
- 5 - Vibration Isolators