

ARMSTRONG

Series 5000



FILE NO:	50.10
DATE:	Mar. 15, 2002
SUPERSEDES:	50.10
DATE:	Apr. 1, 1997

motralec

4 rue Lavoisier . ZA Lavoisier . 95223 HERBLAY CEDEX
Tel. : 01.39.97.65.10 / Fax. : 01.39.97.68.48
Demande de prix / e-mail : service-commercial@motralec.com
www.motralec.com

Sump and Sewage Systems

Sump Series 5200 & 5240

Armstrong offers a complete range of high performance, easily maintained Column Type Sump & Sewage Pumps. Built from the highest quality engineered components, these pumps can be supplied as replacement pumps or as part of a new installation. Armstrong systems are available with control panel, level controls, and sump pit cover plate.

Sump Pump Series 5200 & 5240

Armstrong sump pumps are offered in two designs, engineered to handle a wide range of waste water pumping requirements.

Armstrong sump pump designs address the specific requirements for light-duty or heavy-duty commercial applications such as: elevator pits, electrical tunnels, loading docks, drain tiles, laundry facilities, floor drains and condensate returns.



5240 Sump Pump

5200 Standard Features:

- ◆ 304 centerless ground stainless steel shaft
- ◆ Enclosed-type bronze impeller, keyed to shaft
- ◆ Cast iron inlet strainer
- ◆ Flexible coupling
- ◆ Plate-mounted alemite grease fittings
- ◆ Intermediate grease-lubricated bronze guide bearings for pit depths over 4 ft. (1.2m)

5240 Standard Features:

- ◆ 1/4" (32mm) heavy-duty carbon steel shaft
- ◆ Heavy-duty grease-lubricated bronze guide bearings
- ◆ Enclosed-type cast iron impeller
- ◆ Cast iron inlet strainer
- ◆ Flexible coupling
- ◆ Raised thrust bearing mounted in a dirt and moisture resistant housing
- ◆ Plate-mounted alemite grease fittings
- ◆ Intermediate grease-lubricated bronze guide bearings for pit depths over 5 ft. (1.5m)
- ◆ Flanged pump column pipe

5240 Optional Features:

- ◆ Pump conversion for condensate service consisting of water lubricated graphite pump bearings, stainless steel shaft and bronze impeller
- ◆ Water lubricated cutless rubber bearings
- ◆ Bronze impeller
- ◆ 304 stainless steel shaft

Sewage Series 5400

Armstrong 5400 Series sewage pumping systems for building, municipal and industrial applications provide a top-quality, reliable and long-lasting product.

SEWAGE SERIES 5400 PUMPS

Armstrong sewage pumps feature a screenless design, capable of handling waste material and sewage up to 2½" (64mm) solids.

Standard Features:

- ◆ 1¼" (32mm) carbon steel shaft
- ◆ Gas-tight construction
- ◆ Raised thrust bearing mounted in a dirt and moisture resistant housing
- ◆ Cast iron 2-vane open-type impeller
- ◆ Floor plate mounted alemite grease fittings
- ◆ Grease-lubricated bronze guide bearings for pit depths over 5 ft. (1.5m)
- ◆ Flanged pump and column pipe

Optional Features:

- ◆ Water-lubricated cutless rubber bearings
- ◆ Water-lubricated graphite bearings
- ◆ Bronze impeller
- ◆ 304 stainless steel shaft

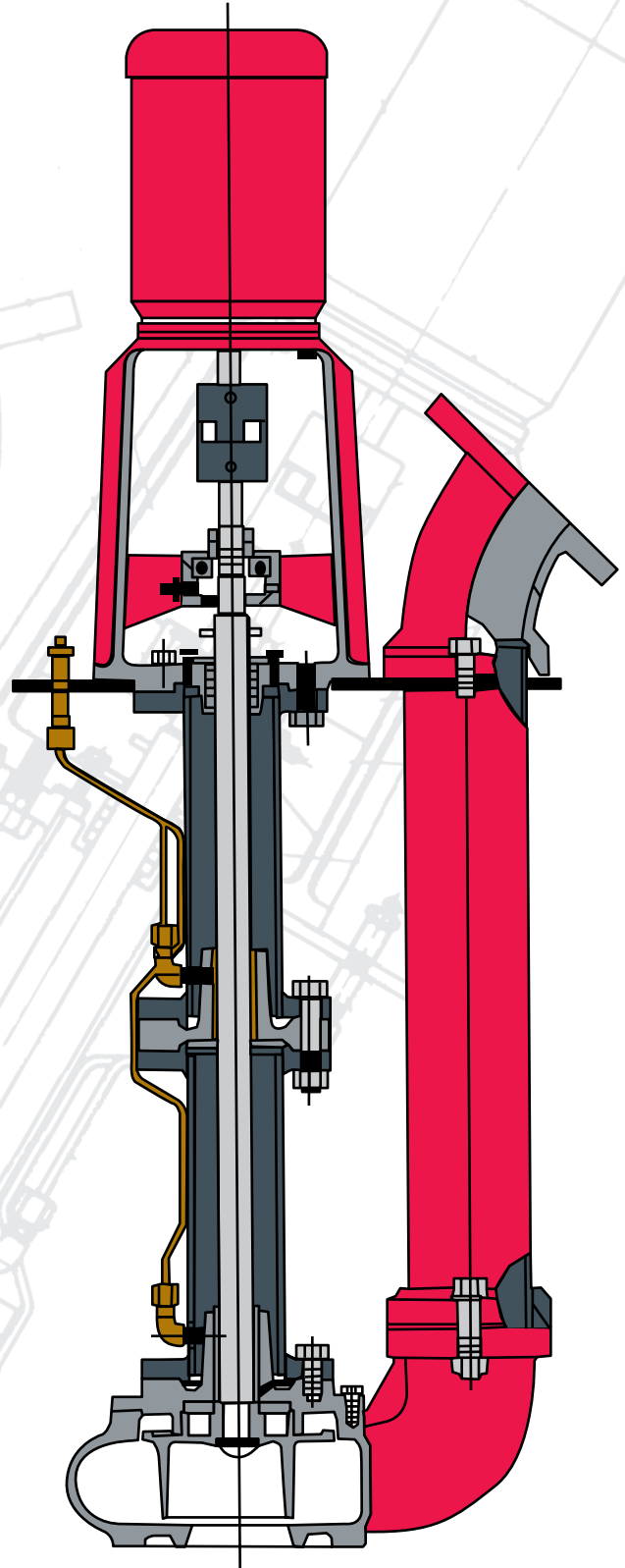

Controls & Accessories

Choose Armstrong pumping systems for reliability, efficiency and quality engineered products.

CONTROL PANEL

Armstrong Sump & Sewage systems are available with a variety of starting equipment choices.

Features:

- ◆ NEMA 1 control panel enclosure
- ◆ UL 508 or CSA approved
- ◆ Main disconnect
- ◆ Thermal and short circuit protection using internal circuit breakers
- ◆ Failure protection with automatic transfer to non-operating pump (duplex system)
- ◆ Control transformer with fused primary (UL 508)
- ◆ Power-on and pump-run indicating lights
- ◆ Hand-Off-Automatic selector switch

Optional Features:

- ◆ NEMA 2, 3, 4, 4X or 7 enclosure
- ◆ High level buzzer or 4" (101mm) bell, indicating light and silence reset push button
- ◆ Overload pilot lights
- ◆ Elapsed time meters
- ◆ Individual disconnect switches
- ◆ Electrical alternation (duplex system)

COVER PLATE AND CURB FRAME

Circular or square sump cover plate and curb frame can be supplied with openings for simplex or duplex pump configurations.

Cover plate includes 3" (76mm) NPT threaded vent and inspection cover.

LEVEL CONTROLS

Ball and rod type float switch governs the control of pump operation based on sump liquid level. Level controls are mounted on a cast iron pedestal and bolted to sump cover plate.

Features:

- ◆ Copper ball, brass float rod and stops, float guide pipe and cast iron pedestal
- ◆ Mechanical alternator with emergency start position is supplied with duplex units

Optional Features:

- ◆ High level alarm devices are mounted on sump cover plate and can be provided in two types:
 - a) NEMA 1 compression type switch with integral buzzer and alarm contract
 - b) Ball & rod float switch, to be wired to separate alarm panel or alarm bell
- ◆ NEMA 4 or NEMA 7 enclosure
- ◆ Bulb-type level controls supplied with mounting plate, electrical connectors, and level control support

COMPRESSION HIGH WATER SWITCH

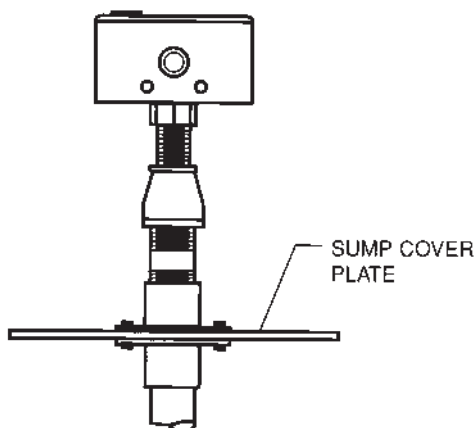

- SENSES STATIC HEAD PRESSURE BETWEEN MEDIA AND BELLOWS IN THE SWITCH ENCLOSURE
- AS LIQUID LEVEL RISES, TRAPPED AIR IN COMPRESSION PIPE CAUSES BELLOWS TO EXPAND AND TRIPS THE MICROSWITCH ACTIVATING AN EXTERNAL CIRCUIT AS WELL AS AN INTEGRAL ALARM

FLOAT SWITCH

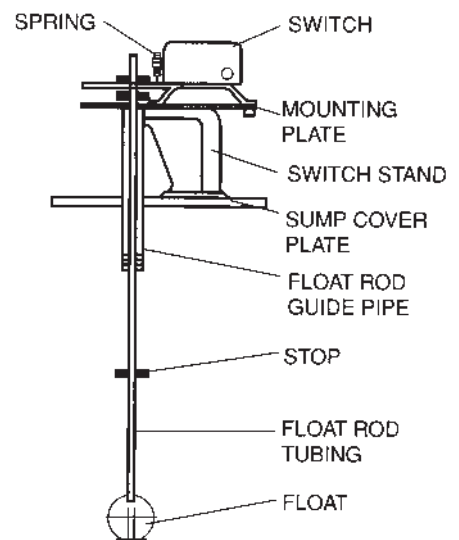

Composite Charts

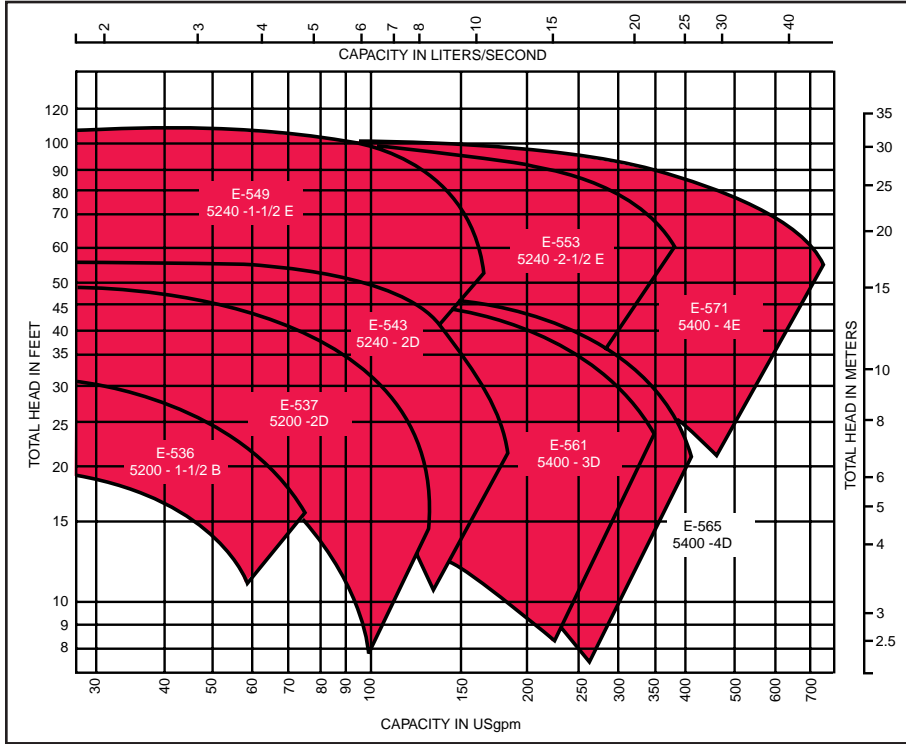

1750 rpm

CURVE NO.	PUMP	SIZE	MAX. SOLID SIZE
E-536	5200	1-1/2B	Bilge water only
E-537	5200	2D	Bilge water only
E-543	5240	2D	Bilge water only
E-549	5240	1-1/2E	Bilge water only
E-553	5240	2-1/2E	Bilge water only
E-561	5400	3D	2"/50mm dia.
E-565	5400	4D	2 1/2"/64mm dia.
E-571	5400	4E	2 1/2"/64mm dia.

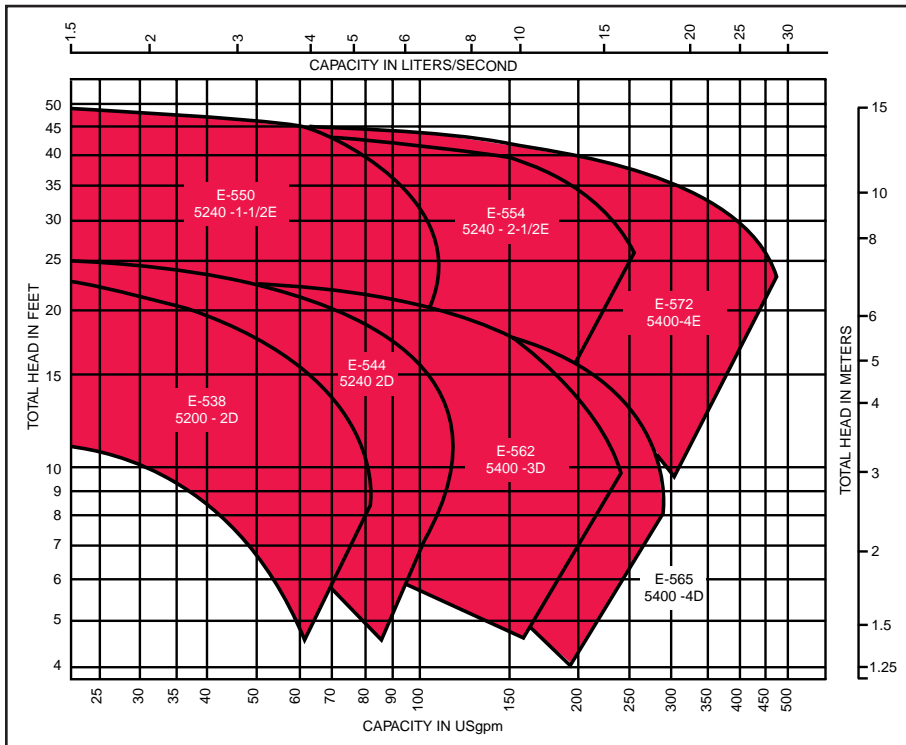

1150 rpm

CURVE NO.	PUMP	SIZE	MAX. SOLID SIZE
E-538	5200	2D	Bilge water only
E-544	5240	2D	Bilge water only
E-550	5240	1-1/2E	Bilge water only
E-554	5240	2-1/2E	Bilge water only
E-562	5400	3D	2"/50mm dia.
E-566	5400	4D	2 1/2"/64mm dia.
E-572	5400	4E	2 1/2"/64mm dia.

Section & Parts List

SERIES 5200 SUMP PUMP

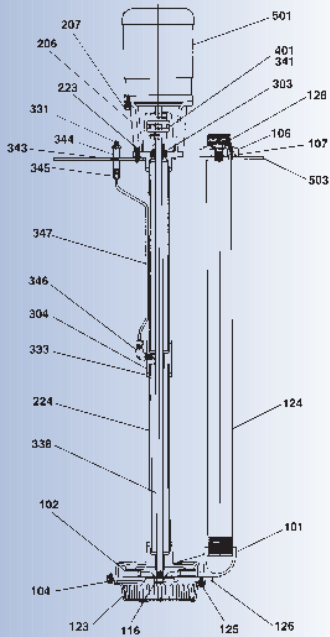

SERIES 5240 SUMP PUMP

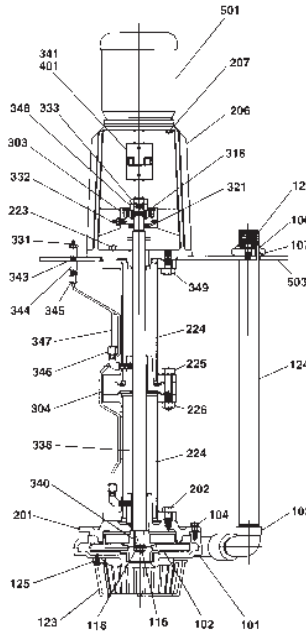

SERIES 5400 SEWAGE PUMP

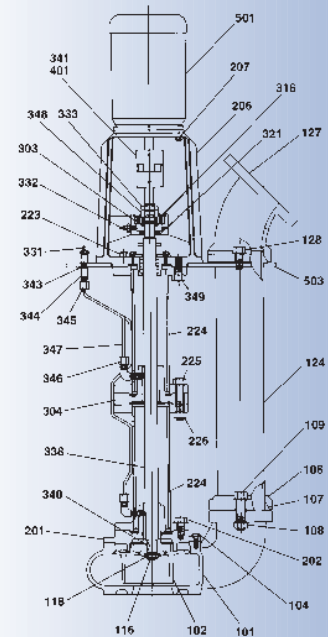

ITEM No. DESCRIPTION

101	Volute
102	Impeller
103	Lower Discharge Elbow
104	Volute Screw
106	Discharge Flange
107	Discharge Flange Gasket
108	Flange Nut
109	Flange Bolt
116	Impeller Nut
118	Impeller Washer
123	Strainer
124	Discharge Pipe
125	Strainer Screw
126	Suction Plate
127	Discharge Elbow

ITEM No. DESCRIPTION

128	Discharge Pipe Screw & Washer
201	Cover Plate & Lower Bearing
202	Cover Plate Screw
206	Motor Support
207	Motor Screw
223	Support Screw
224	Column Pipe
225	Intermediate Bearing Screw
226	Intermediate Bearing Nut
303	Ball Bearing
304	Intermediate Bearing Assembly
316	Snap Ring
321	Oil Seal
331	Grease Fitting

ITEM No. DESCRIPTION

332	Grease Fitting
333	Lock Nut
338	Shaft
340	Impeller Key
341	Coupling Key
343	Pipe Nipple
344	Pipe Coupling
345	Tube Connector
346	Elbow
347	Lubrication Tube
348	Bearing Collar
349	Bearing Frame Screw
401	Coupling
501	Motor
503	Floor Plate

Dimensional Data

COVER PLATES - SIMPLEX UNITS inches (mm)

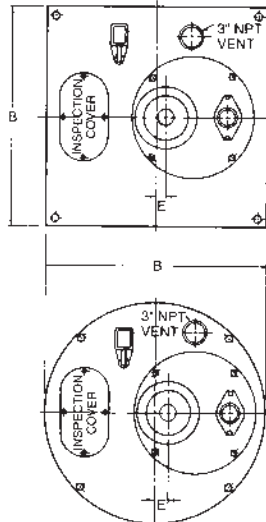

HIGH WATER ALARM (NOTE 1)

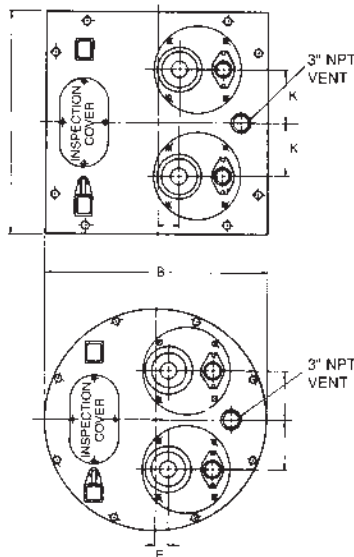
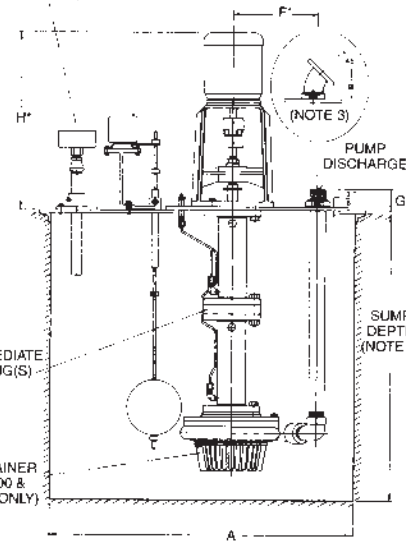

	A SUMP SIZE	B	E							
			5200		5240		5400			
			1-1/2B	2D	2D	1-1/2E	2-1/2E	3D	4D	4E
ROUND	24 (610)	28 (711)	3 (76)	3 (76)	1-1/4 (32)	1-1/4 (32)	1-3/4 (44)	1 (25)	1/4 (6)	1/4 (6)
	30 (762)	34 (864)	6 (152)	6 (152)	1-3/4 (44)	1-3/4 (44)	1-1/4 (32)	4 (102)	2-3/4 (70)	2-3/4 (70)
	36 (914)	40 (1016)	8 (203)	8 (203)	3-3/4 (95)	3-3/4 (95)	3-1/4 (83)	6 (152)	4-3/4 (121)	4-3/4 (121)
	42 (1067)	46 (1168)	11 (279)	11 (279)	6-3/4 (171)	6-3/4 (171)	6-1/4 (159)	9 (229)	7-3/4 (197)	7-3/4 (197)
	48 (1219)	54 (1372)	11 (279)	11 (279)	6-3/4 (171)	6-3/4 (171)	6-1/4 (159)	9 (229)	7-3/4 (197)	7-3/4 (197)
	54 (1372)	60 (1524)	11 (279)	11 (279)	6-3/4 (171)	6-3/4 (171)	6-1/4 (159)	9 (229)	7-3/4 (197)	7-3/4 (197)
	60 (1524)	66 (1676)	11 (279)	11 (279)	6-3/4 (171)	6-3/4 (171)	6-1/4 (159)	9 (229)	7-3/4 (197)	7-3/4 (197)
SQUARE	24 (610)	28 (711)	3 (76)	3 (76)	1-1/4 (32)	1-1/4 (32)	1-3/4 (44)	1 (25)	1/4 (6)	1/4 (6)
	30 (762)	34 (864)	6 (152)	6 (152)	1-3/4 (44)	1-3/4 (44)	1-1/4 (32)	4 (102)	2-3/4 (70)	2-3/4 (70)
	36 (914)	40 (1016)	8 (203)	8 (203)	3-3/4 (95)	3-3/4 (95)	3-1/4 (83)	6 (152)	4-3/4 (121)	4-3/4 (121)
	42 (1067)	46 (1168)	11 (279)	11 (279)	6-3/4 (171)	6-3/4 (171)	6-1/4 (159)	9 (229)	7-3/4 (197)	7-3/4 (197)
	48 (1219)	54 (1372)	11 (279)	11 (279)	6-3/4 (171)	6-3/4 (171)	6-1/4 (159)	9 (229)	7-3/4 (197)	7-3/4 (197)
	54 (1372)	60 (1524)	11 (279)	11 (279)	6-3/4 (171)	6-3/4 (171)	6-1/4 (159)	9 (229)	7-3/4 (197)	7-3/4 (197)
	60 (1524)	66 (1676)	11 (279)	11 (279)	6-3/4 (171)	6-3/4 (171)	6-1/4 (159)	9 (229)	7-3/4 (197)	7-3/4 (197)

MOTOR FRAME SIZE inches (mm)

SERIES	56C	143TC	145TC	182TC	184TC	213TC	215TC	254TC	256TC
5200 H (approx.)	16-5/8 (422)	16-1/2 (419)	17-1/2 (445)	-	-	-	-	-	-
5240 & 5400 H (approx.)	21-1/2 (546)	22 (559)	22 (559)	22-3/4 (578)	25-1/2 (648)	26-1/4 (667)	27-3/4 (705)	28-3/4 (730)	30-3/4 (781)

COVER PLATES - DUPLEX UNITS inches (mm)

	A SUMP SIZE	B	E							K	
			5200		5240		5400				
			1-1/2B	2D	2D	1-1/2E	2-1/2E	3D	4D		4E
ROUND	36 (914)	40 (1016)	2 (51)	2 (51)	2-1/4 (57)	2-1/4 (57)	2-3/4 (70)	0 (0)	1-3/4 (44)	1-3/4 (44)	10
	42 (1067)	46 (1168)	6 (152)	6 (152)	1-3/4 (44)	1-3/4 (44)	1-1/4 (32)	4 (102)	2-3/4 (70)	2-3/4 (70)	10
	48 (1219)	54 (1372)	9 (229)	9 (229)	4-3/4 (121)	4-3/4 (121)	4-1/4 (108)	7 (178)	5-3/4 (146)	5-3/4 (146)	12
	54 (1372)	60 (1524)	10 (254)	10 (254)	5-3/4 (146)	5-3/4 (146)	5-1/4 (133)	8 (203)	6-3/4 (171)	6-3/4 (171)	14
	60 (1524)	66 (1676)	10 (254)	10 (254)	5-3/4 (146)	5-3/4 (146)	5-1/4 (133)	8 (203)	6-3/4 (171)	6-3/4 (171)	16
	72 (1829)	78 (1981)	12 (305)	12 (305)	7-3/4 (197)	7-3/4 (197)	7-1/4 (184)	10 (254)	8-3/4 (222)	8-3/4 (222)	18
	SQUARE	36 (914)	40 (1016)	8 (203)	8 (203)	3-3/4 (95)	3-3/4 (95)	3-1/4 (83)	6 (152)	4-3/4 (121)	4-3/4 (121)
42 (1067)		46 (1168)	9 (229)	9 (229)	4-3/4 (121)	4-3/4 (121)	4-1/4 (108)	7 (178)	5-3/4 (146)	5-3/4 (146)	11
48 (1219)		54 (1372)	11 (279)	11 (279)	6-3/4 (171)	6-3/4 (171)	6-1/4 (159)	9 (229)	7-3/4 (197)	7-3/4 (197)	12
54 (1372)		60 (1524)	10 (254)	10 (254)	5-3/4 (146)	5-3/4 (146)	5-1/4 (133)	8 (203)	6-3/4 (171)	6-3/4 (171)	14
60 (1524)		66 (1676)	10 (254)	10 (254)	5-3/4 (146)	5-3/4 (146)	5-1/4 (133)	8 (203)	6-3/4 (171)	6-3/4 (171)	16
72 (1829)		78 (1981)	13 (330)	13 (330)	8-3/4 (222)	8-3/4 (222)	8-1/4 (210)	11 (279)	9-3/4 (248)	9-3/4 (248)	18

SUMP DEPTH IN FEET (m)	NO. OF INTERMEDIATE BEARINGS
0 to 3.5 (0 to 1.07)	(5200) 0
0 to 4.5 (0 to 1.4)	(5240+5400) 0
4 to 6 (1.2 to 1.9)	(5200) 1
5 to 8 (1.5 to 2.4)	(5240+5400) 1
6.5 to 8 (2 to 2.4)	(5200) 2
9 to 12 (2.7 to 3.7)	(5240+5400) 2
	(5200) 3

PUMP SIZE inches (mm)

PUMP SIZE	F	G	PUMP DISCHARGE
5200 1-1/2 B	6-1/2 (165)	4-1/2 (114)	Screwed 1-1/2" NPT
5200 2D	7 (178)	5 (127)	Screwed 2" NPT
5240 2D	11-1/8 (283)	2-1/4 (57)	Screwed 2" NPT
5240 1-1/2 E	10-1/4 (260)	3 (76)	Screwed 1-1/2" NPT
5240 2-1/2 E	11-1/4 (286)	3 (76)	Screwed 2-1/2" NPT
5400 3D	9 (229)	4 (95)	Screwed 3" NPT
5400 4D	10-7/8 (276)	7-1/4 (184)	Flanged 4" 125#ASA
5400 4E	11-7/8 (302)	7-1/4 (184)	Flanged 4" 125#ASA

NOTE 1: High water alarm furnished only when specified.

NOTE 2: Sump depth determined by actual job requirements.

NOTE 3: Series 5200 and 5240 have Vertical Discharge.

Series 5400 has 45° Elbow Discharge.

*Dimensions F, G, & H apply to both Simplex and Duplex units.

Pump floor plates are 19" (504mm) in diameter with four 3/8" (11mm) holes on a 19" (483mm) bolt circle.

† Denotes minus dimension as centerline of pump is left of cover plate center.

Typical Specifications

Furnish and install, as illustrated on the plans & specifications, an Armstrong Series 5000 simplex or duplex pumping system.

PUMPS - 5200

Sump Pump shall be **Model: 5200** _____ vertical centrifugal, flexible coupled for sump service. Each pump shall provide _____ USgpm at _____ feet of TDH at a speed of _____ rpm. Pump length will be suitable for a pit depth of _____ feet.

The pump casing shall be cast iron with a bronze enclosed impeller complete with a cast iron inlet strainer.

Pump shaft shall be one piece 304 centerless ground stainless steel. Pump shaft shall be guided by grease-lubricated upper ball bearing and intermediate bronze sleeve type column bearing(s). Pump column assembly is constructed of threaded steel schedule 80 pipe.

Intermediate bearing(s) are greased by a lubrication system consisting of 1/4" (6.35mm) copper grease lines and Alemite fittings terminating at floor plate.

PUMPS - 5240

Sump Pump shall be **Model: 5240** _____ vertical centrifugal, flexible coupled for sump service. Each pump shall provide _____ USgpm at _____ feet of TDH at a speed of _____ rpm. Pump length will be suitable for a pit depth of _____ feet.

The pump casing shall be cast iron with a cast iron enclosed impeller complete with a cast iron inlet strainer.

Pump shaft shall be one piece 1 1/4" (32mm) diameter carbon steel or 304 turned and polished stainless steel. Pump Shaft shall be guided by grease-lubricated upper ball bearing and intermediate bronze sleeve type column bearing(s). Flanged steel column assembly is complete with register fit guide bearing housings to ensure proper alignment.

The upper bearing(s) will be ball type, heavy duty grease-lubricated, mounted in a raised bearing housing to prevent moisture, and dust and dirt contact. Intermediate and lower bearing(s) are greased by a lubrication system consisting of 1/4" (6.35mm) copper grease lines and Alemite fitting(s) terminating at floor plate.

PUMPS - 5400

Sewage Pump shall be **Model: 5400** _____ vertical centrifugal, flexible coupled for sewage service. Each pump shall provide _____ USgpm at _____ feet of TDH at a speed of _____ rpm. Pump length will be suitable for a pit depth of _____ feet. Pump shall be capable of passing solids sizes of 2" (51mm) and 2 1/2" (64mm).

The pump casing shall be cast iron complete with a non-clog cast iron 2 vane open type impeller.

Pump shaft shall be one piece 1 1/4" (32mm) diameter carbon steel or 304 turned and polished stainless steel. Pump shaft shall be guided by grease-lubricated upper ball bearing(s) and intermediate bronze sleeve type column bearing(s). Flanged steel column assembly is complete with register fit guide bearing housings to ensure proper alignment. Packing seal provides "GAS TIGHT" construction.

The upper bearing(s) will be a ball type, heavy duty grease-lubricated, mounted in a raised bearing housing to prevent moisture, and dust and dirt contact. Intermediate and lower bearing(s) are greased by a lubrication system consisting of 1/4" (6.35mm) copper grease lines and Alemite fitting(s) terminating at floor plate.

MOTOR

Pump motor shall be a vertical type round body design. Motor horsepower shall be not less than _____ hp, _____ volts, _____ phase, 60 Hz. Motor Enclosure shall be ODP, TEFC or Explosion Proof.

OPTIONAL CONSTRUCTION: 5240 & 5400 PUMPS

Cutless Rubber Lower & Intermediate Sleeve Bearings: Cutless Rubber Lower & Intermediate Sleeve Bearings are provided to handle abrasive liquids without scoring or damaging the shaft. A separate fresh water line connection is provided for connection to outside source with solenoid valve (supplied by others) to be energized when pump motor operates. Pumps are complete with stainless steel shaft for longer bearing life.

Graphite Lower & Intermediate Bearings:

Graphalloy intermediate and lower bearings are provided to handle liquids above 150°F (65°C). Pump is complete with stainless steel shaft for longer bearing life. For condensate applications, pump is complete with bronze impeller.

PUMP CONTROL

Pump control shall be ball & rod mechanical float switch. Unit consists of copper ball, brass rod & stops. Float switch is mounted on a cast iron pedestal and bolted to sump cover plate.

Duplex unit with mechanical alternating float switch complete with high level emergency start position turning on both pumps in case of high liquid level.

HIGH LEVEL ALARM

System shall include compression type high water alarm complete with alarm buzzer and additional contact for remote signaling. Alarm shall be housed in a NEMA 1 enclosure and mounted on sump cover plate.

CONTROL PANEL

Armstrong series 5000 systems shall include NEMA 1 Control Panel with the following Standard Features:

- UL 508 or CSA approved
- Main Disconnect
- Thermal and Short Circuit Protection using Internal Circuit Breakers
- Failure Protection with Automatic Transfer to Non-Operating Pump (Duplex System)
- Control Transformer with Fused Primary (UL 508 only)
- Power-On and Pump-Run Indicating Light
- Hand-Off-Automatic Selector Switch

OPTIONAL CONTROL FEATURES

- NEMA 2, 3, 4, 4X or 7 Enclosure
- High Level Buzzer or 4" (101mm) Bell, Indicating Light and Silence Reset Push Button
- Overload Pilot Lights
- Elapsed Time Meters
- Individual Disconnect Switches

COVER PLATE AND CURB FRAME

Circular or square sump cover plate and curb frame shall be supplied with openings for simplex and duplex pump configurations. Cover plate includes 3" (76mm) NPT threaded vent and inspection cover. Printed in Canada



motralec

4 rue Lavoisier . ZA Lavoisier . 95223 HERBLAY CEDEX
Tel. : 01.39.97.65.10 / Fax. : 01.39.97.68.48
Demande de prix / e-mail : service-commercial@motralec.com

www.motralec.com