



The Premium Pump

LKH Centrifugal Pump

Applications

The LKH pump is a highly efficient and economical centrifugal pump, which meets the requirements of sanitary and gentle product treatment and chemical resistance. LKH is available in thirteen sizes, LKH-5, -10, -15, -20, -25, -35, -40, -45, -50, -60, -70, -85 and -90.

Standard design

The LKH pump consists of a motor, stub shaft, mechanical compression coupling (LKH-5 with pin bolts), adaptor, back plate, impeller, pump casing and shaft seal. (LKH-5 has clamp connection between pump casing and back plate). The LKH pump is designed for CIP with emphasis on large internal roundings and cleanable seals. The sanitary version of LKH has a stainless steel shroud for protection of the motor, and the complete unit is supported on four adjustable stainless steel legs.

Shaft seals

The LKH pump is equipped with either an external single or a flushed shaft seal. Both have stationary seal rings in acid resistant steel AISI 329 with sealing surface in silicon carbide and rotating seal rings in carbon. The secondary seal of the flushed seal is a long lasting lip seal. The pump may also be equipped with a double mechanical shaft seal.

Materials

Product wetted steel parts: Acid-resistant steel 1.4404 (316L).

Other steel parts: Stainless steel 1.4301 (304).

Finish: Semi bright.

Product wetted seals: EPDM rubber.

Technical data

Max. inlet pressure:

LKH-5: 600 kPa (6 bar)

LKH-10 - 70: 1000kPa (10 bar).

LKH-85 - 90: 500kPa (5 bar).

Temperature range: -10°C to +140°C (EPDM).

Flushed shaft seal:

Water pressure inlet: Max. 1 bar.

Water consumption: 0.25 -0.5 l/min.

Double mechanical shaft seal:

Water pressure inlet, LKH-5 to -60: . . . Max. 500 kPa (5 bar).

Water pressure inlet, LKH-70 and -90: . Max. 300 kPa (3 bar).

Water consumption: 0.25 -0.5 l/min.

Connections for FSS and DMSS:

R 1/8" (BSP) external thread.

(LKH 85: 6mm tube/Rp 1/8").



LKH-10 with shroud and legs.

Motor

Foot-flanged motor according to the IEC metric standard, 2 poles = 3000/3600 rpm at 50/60 Hz, IP 55 (with drain hole with labyrinth plug), insulation class F.

LKH-90 4 poles = 1500/1800 rpm at 50/60 Hz.

Voltage and frequency

3 ~, 50 Hz, 220-240V Δ/380-420VY ≤ 4 kW

3 ~, 60 Hz, 250-280V Δ/440-480VY ≤ 4.6 kW

3 ~, 50 Hz, 380-420V Δ/660-690VY ≥ 5.5 kW

3 ~, 60 Hz, 440-480V Δ ≥ 6.4 kW

Motor sizes

50 Hz: 0.75 - 1.1 - 1.5 - 2.2 - 3 - 4 - 5.5 - 7.5 - 11 - 15 - 18.5 - 22 - 30 - 37 - 45 - 55 - 75 - 90 - 110 kW.

60 Hz: 0.9 - 1.3 - 1.75 - 2.5 - 3.5 - 4.6 - 6.4 - 8.6 - 12.5 - 17 - 21 - 25 - 35 - 43 - 52 - 63 - 86 - 105 - 125 kW.

Warranty

Extended 3-years warranty on LKH pumps. The warranty covers all non wear parts on the condition that genuine Alfa Laval Spare Parts are used.

motralec

4 rue Lavoisier . ZA Lavoisier . 95223 HERBLAY CEDEX

Tel. : 01.39.97.65.10 / Fax. : 01.39.97.68.48

Demande de prix / e-mail : service-commercial@motralec.com

www.motralec.com

Dimensions (mm)

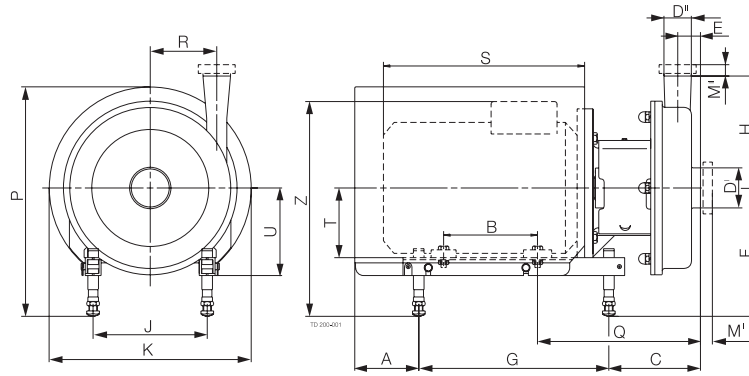

LKH-5

	Motor		
	kW		
	0.75/1.1	1.5	2.2
A	44	79	79
B	100	100	125
C	125	131	131
E	22	22	22
F min.	183	189	189
F max.	275	275	275
G	272	272	272
H	158	158	158
J	125	140	140
K	251	288	288
P min.	308	346	346
P max.	400	432	432
Q	207	213	213
R	71	71	71
S	232	245	270
T	80	90	90
U	125	125	125
Z min.	295	316	316
Z max.	389	402	402
Weight (kg)	27	30	33

LKH-10

	Motor			
	kW			
	1.5	2.2	3	4
A	79	79	78	81
B	100	125	140	140
C	132	132	140	147
E	23	23	23	23
F min.	189	189	185	184
F max.	275	275	295	297
G	272	272	320	320
H	142	142	142	142
J	140	140	160	190
K	288	288	323	359
P min.	346	346	357	383
P max.	432	432	467	496
Q	215	215	235	242
R	87	87	87	87
S	245	270	299	301
T	90	90	100	112
U	125	125	145	147
Z min.	316	316	321	330
Z max.	402	402	431	443
Weight (kg)	36	39	47	57

LKH-15

	Motor		
	kW		
	3	4	5.5
A	78	81	81
B	140	140	178
C	176	183	181
E	43	43	43
F min.	185	184	184
F max.	295	297	317
G	320	320	400
H	166	166	166
J	160	190	216
K	323	359	383
P min.	357	383	380
P max.	467	492	513
Q	271	278	316
R	66	66	66
S	299	301	402
T	100	112	132
U	145	147	167
Z min.	321	330	348
Z max.	431	443	481
Weight (kg)	51	61	79

LKH-20

	Motor				
	kW				
	1.5	2.2	3	4	5.5/7.5
A	79	79	78	81	81
B	100	125	140	140	178
C	145	145	152	159	157
E	27	27	27	27	27
F min.	189	189	185	184	184
F max.	275	275	295	297	317
G	272	272	320	320	400
H	180	180	180	180	180
J	140	140	160	190	216
K	288	288	323	359	383
P min.	346	346	357	383	380
P max.	432	432	467	496	513
Q	227	227	247	254	292
R	88	88	88	88	88
S	245	270	299	301	402
T	90	90	100	112	132
U	125	125	145	147	167
Z min.	316	316	321	330	348
Z max.	402	402	431	443	481
Weight (kg)	38	41	49	59	77

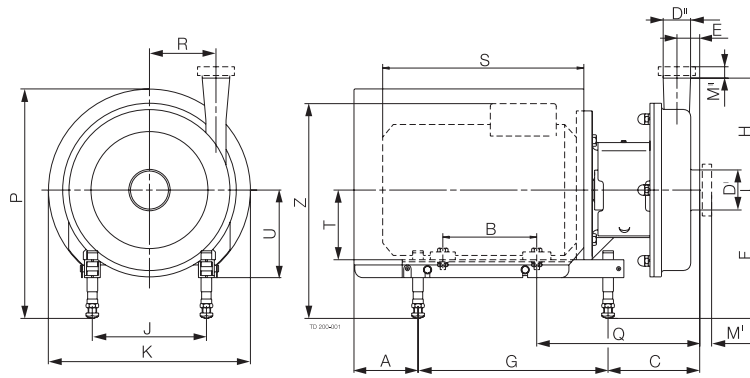

LKH-25

	Motor kW	
	5.5/7.5	11/15
A	81	170
B	178	210
C	163	192
E	32	32
F min.	184	228
F max.	317	345
G	400	483
H	193	193
J	216	254
K	383	485
P min.	380	490
P max.	513	607
Q	298	345
R	106	106
S	402	571
T	132	160
U	167	195
Z min.	348	438
Z max.	481	554
Weight (kg)	81	125/134

LKH-35

	Motor kW		
	4	5.5/7.5	11/15
A	81	81	170
B	140	178	210
C	150	148	177
E	23	23	23
F min.	184	184	228
F max.	297	317	345
G	320	400	483
H	193	193	193
J	190	216	254
K	359	383	485
P min.	383	380	490
P max.	496	513	607
Q	245	283	330
R	119	119	119
S	301	402	571
T	112	132	160
U	147	167	195
Z min.	330	348	438
Z max.	443	481	554
Weight (kg)	63	81	125/134

LKH-40

	Motor kW		
	7.5	11/15/18.5	22
A	81	170	196
B	178	210	241
C	158	187	201
E	28	28	28
F min.	184	228	260
F max.	317	345	365
G	400	483	508
H	212	212	212
J	216	254	279
K	383	485	533
P min.	380	490	546
P max.	513	607	671
Q	293	340	353
R	126	126	126
S	402	571	616
T	132	160	180
U	167	195	215
Z min.	348	438	484
Z max.	481	554	589
Weight (kg)	84	128/137/147	174

LKH-45

	Motor kW		
	4	5.5/7.5	11/15
A	81	81	170
B	140	178	210
C	179	177	206
E	41	41	41
F min.	184	184	228
F max.	297	317	345
G	320	400	483
H	193	193	193
J	190	216	254
K	359	383	485
P min.	383	380	490
P max.	496	513	607
Q	274	312	359
R	97	97	97
S	301	402	571
T	112	132	160
U	147	167	195
Z min.	330	347	438
Z max.	443	480	555
Weight (kg)	65	83	127/136

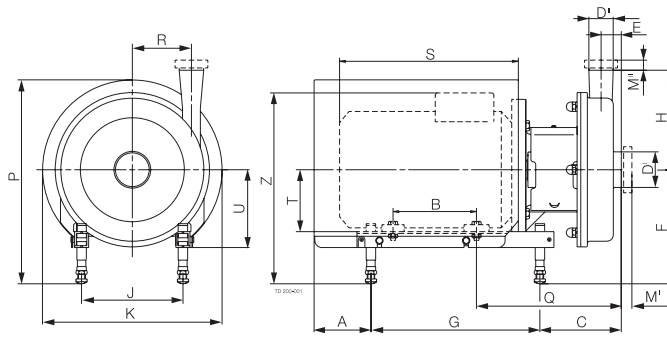

LKH-50

	Motor kW		
	5.5/7.5	11/15/18.5	22
A	81	170	196
B	178	210	241
C	171	200	213
E	35	35	35
F min.	184	228	260
F max.	317	345	365
G	400	483	508
H	205	205	205
J	216	254	279
K	383	485	534
P min.	380	490	546
P max.	513	607	671
Q	306	353	366
R	118	118	118
S	402	571	616
T	132	160	180
U	167	195	215
Z min.	348	438	484
Z max.	481	554	589
Weight (kg)	86	130/139/149	174

LKH-60

	Motor kW			
	5.5/7.5	11/15/18.5	22	30
A	81	170	196	246
B	178	210	241	305
C DN150	250	279	292	304
C 4"	200	229	242	254
C clamp 6"	240	269	282	294
E DN150	112	112	112	112
E 4"	62	62	62	62
E clamp 6"	102	102	102	102
F min.	184	228	260	274
F max.	317	345	365	385
G	400	483	508	534
H	262	262	262	262
J	216	254	279	318
K	383	485	534	673
P min.	380	490	546	661
P max.	513	607	671	786
Q DN150	385	432	445	457
Q 4"	335	382	395	407
Q clamp 6"	375	422	435	447
R	102	102	102	102
S	402	571	616	711
T	132	160	180	200
U	167	195	215	220
Z min.	348	437	484	571
Z max.	481	554	589	682
Weight (kg)	94	138/147/157	182	277

900002/15

LKH-70

	Motor kW				
	5.5/7.5	11/15/18.5	22	30/37/45	55/75
A	81	170	196	246	389
B	178	210	241	305	310/349
C 4"	190	212	226	238	277
C 6" clamp/DN150	280	302	316	328	367
E 4"	25	25	25	25	25
E 6" clamp/DN150	115	115	115	115	115
F min.	184	228	260	274	401
F max.	317	345	365	385	462
G	400	483	508	534	640
H 3"	254	254	254	254	254
H 4"/DN100	335	335	335	335	335
J	216	254	279	318	406
K	383	485	534	673	753
P min.	380	490	546	661	811
P max.	513	607	671	786	872
Q 4"	325	365	378	390	471
Q 6" clamp/DN150	415	455	468	480	561
R	147	147	147	147	147
S	402	571	616	711	744
T	132	160	180	200	250
U	167	195	215	220	
Z min.	348	437	484	571	776
Z max.	481	554	589	682	837
Weight (kg)	107/126	149/160/170	216	313/326/345	461/508

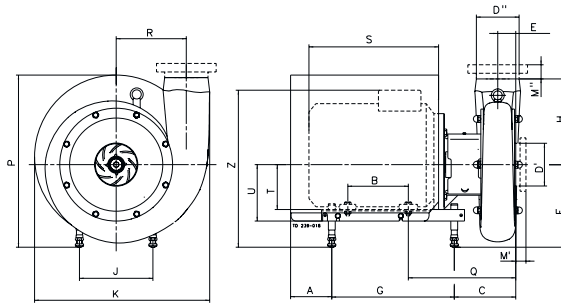

LKH-85

	Motor kW		
	30/37/45	55/75	90/110
A	246	389	244
B	305	310/349	419
C	298	254	363
E	65	65	65
F min.	289	401	431
F max.	385	462	492
G	534	640	757
H	229	229	229
J	318	406	457
K	673	753	960
P min.	689	811	841
P max.	786	872	902
Q	407	492	514
R	220	220	220
S	711	744	948
T	200	250	280
U	220	220	220
Z min.	586	776	806
Z max.	682	837	867
Weight (kg)	336/349/368	487/531	844/904

LKH-90

	Motor kW	
	30/37/45	55/75
A	246	389
B	305	310/349
C	252	295
E	65	65
F min.	289	401
F max.	385	462
G	534	640
H	310	310
J	318	406
K	673	753
P min.	689	811
P max.	786	872
Q	404	490
R	250	250
S	711	744
T	200	250
U	220	220
Z min.	586	776
Z max.	682	837
Weight (kg)	383/396/415	520/567

Options

- A. Impeller with reduced diameter.
- B. Impeller screw/nut (standard for LKH-70 - LKH-90).
- C. Motor for other voltage and/or frequency.
- D. Motor with increased safety/flame proof motor.
- E. Inducer (only LKH-10 to -50).
- F. Flushed shaft seal.
- G. Double mechanical shaft seal.
- H. Wider clearance between impeller and backplate if there is a risk of building up a hard layer of product. Standard clearance is 0.5 mm (1 mm for LKH-70/90) and can be made up to 2.5 mm.
- I. Surface roughness, product wetted parts: $R_a \leq 0.8 \mu\text{m}$.
- J. Product wetted seals of Nitrile (NBR), Fluorinated rubber (FPM) or FEP.
- K. Rotating seal ring of Silicon Carbide.

Ordering

Please state the following when ordering:

- Pump size.
- Connections.
- Impeller diameter.
- Motor size.
- Voltage and frequency.
- Flow, pressure and temperature.
- Density and viscosity of the product.
- Options.

Note!

For further details, see also IM 70737.

This product has EHEDG certification

Flow chart

Frequency: 50 Hz Speed (synchr): 3000 rpm

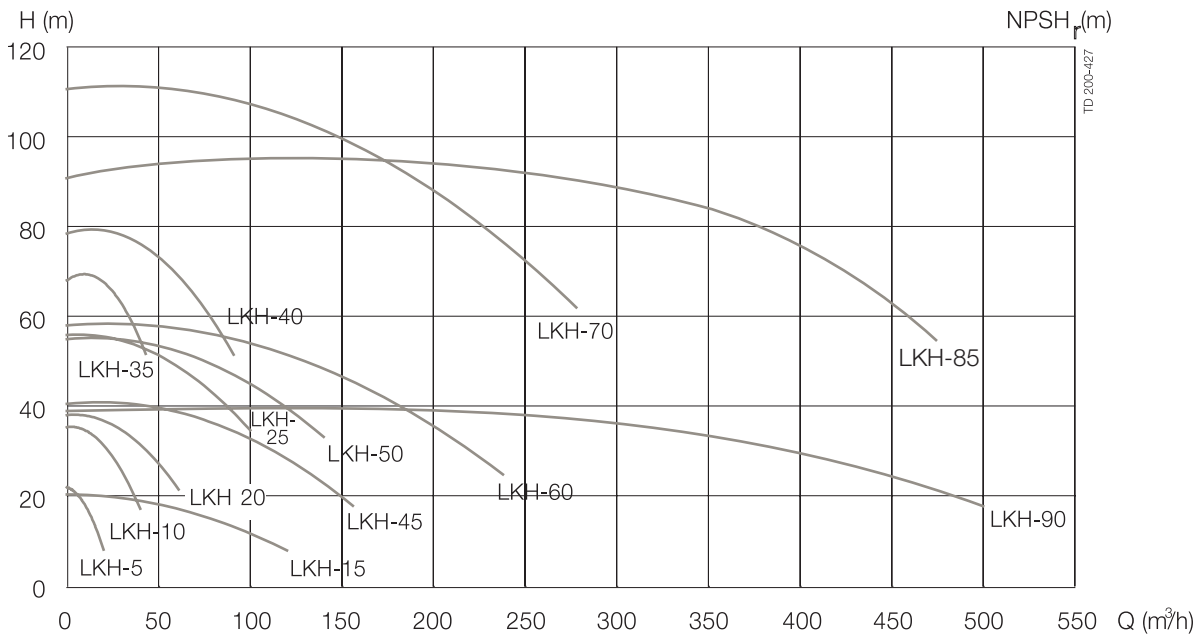

Connections (mm) Sanitary version

LKH-5

D ^I : 51	ISO	ISO	DIN	SMS	BS	DS
D ^{II} : 38	Clamp	Male	Male	Male	Male	Male
M ^I	21	21	22	20	27	20
M ^{II}	21	21	22	20	27	20

LKH-15, -45, -50, -70

D ^I : 101.6	ISO	ISO	DIN	SMS	BS
D ^{II} : 76.1	Clamp	Male	Male	Male	Male
M ^I	21	21	30	35	32
M ^{II}	21	21	30	24	27

LKH-10, -20, -35

D ^I : 63.5	ISO	ISO	DIN	SMS	BS	DS
D ^{II} : 51	Clamp	Male	Male	Male	Male	Male
M ^I	21	21	25	24	27	24
M ^{II}	21	21	22	20	27	20

LKH-60

D ^I : 101.6	ISO	ISO	DIN	SMS	BS
D ^{II} : 101.6	Clamp	Male	Male	Male	Male
M ^I	21	21	30	35	32
M ^{II}	21	21	30	35	32

LKH-25

D ^I : 76.1	ISO	ISO	DIN	SMS	BS	DS
D ^{II} : 63.5	Clamp	Male	Male	Male	Male	Male
M ^I	21	21	30	24	27	24
M ^{II}	21	21	25	24	27	24

LKH-60, -70

D ^I : DN150	DIN	D ^I : 6"	ASME
D ^{II} : DN100	Clamp	D ^{II} : 4"	BPE
M ^I	50	M ^I	38
M ^{II}	30	M ^{II}	16

LKH-40

D ^I : 76.1	ISO	ISO	DIN	SMS	BS	DS
D ^{II} : 63.5	Clamp	Male	Male	Male	Male	Male
M ^I	21	21	30	24	27	24
M ^{II}	12	21	27	24	22	21

LKH-85, -90

D ^I : DN150	DIN	D ^I : 6"	ASME
D ^{II} : DN150	Male	D ^{II} : 6"	BPE
M ^I	50	M ^I	38
M ^{II}	50	M ^{II}	38

ESE00263EN 1001

The information contained herein is correct at the time of issue,
but may be subject to change without prior notice.

motralec

4 rue Lavoisier . ZA Lavoisier . 95223 HERBLAY CEDEX
Tel. : 01.39.97.65.10 / Fax. : 01.39.97.68.48
Demande de prix / e-mail : service-commercial@motralec.com
www.motralec.com