

C-ATEX plug fan – ZAmotbasicEx

Centrifugal fans main catalogue with IEC standard motor

C-ATEX plug fan

ER71C

Motor ZAmotbasicEx IE3



Description

Plug fan with high performance centrifugal impeller
 Impeller made of bright sheet metal powder-coated resistance class 3 (L-TI-0585) RAL 9005 (jet black)
 Inlet nozzle with measuring device for air flow measurement
 Fitting position H (horizontal)
 Rated voltage U_N : 3~ 400 V
 Rated frequency f_N : 50 Hz
 Motor protection: PTC resistor
 Degree of protection: IP56
 Thermal class: THCL155
 Min. permitted medium temperature $t_{R(min)}$: -20 °C
 Max. permitted medium temperature $t_{R(max)}$ at n_{max} : 40 °C
 Ex marking fan (mechanical): II 2G c IIB T4
 Ex marking motor (electrical): II 2G Ex h IIB T4 Gb

Nozzle coefficients

Standard k	490
With guard grille k_g	429

Characteristic curve

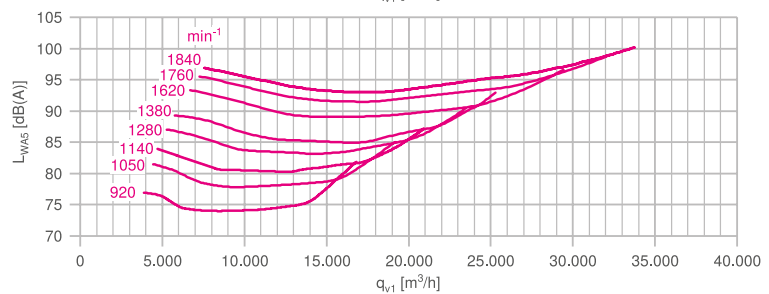
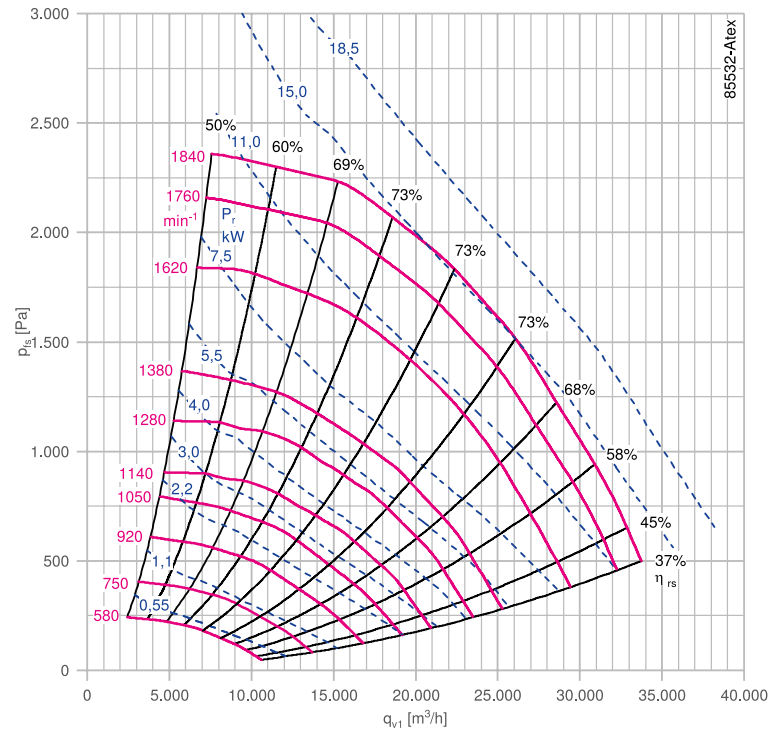

Dimensions mm

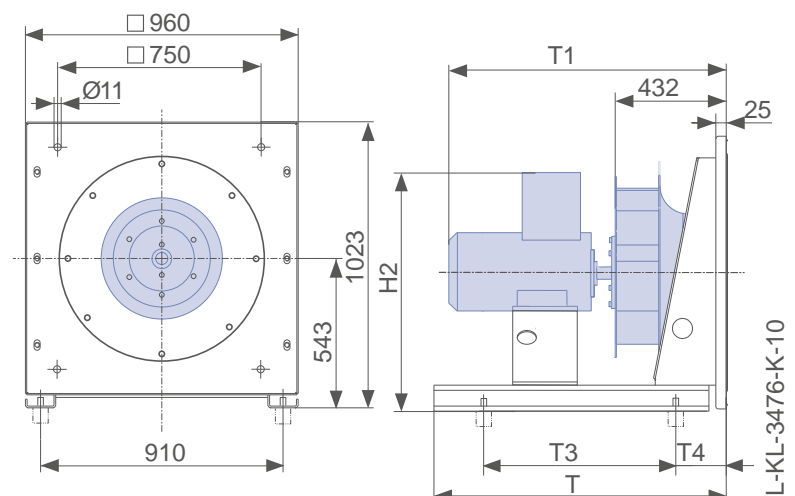

C-ATEX-ZAmotbasicEx IE3								
Rated power P_N kW	Type	Article no.	Motor size	Motor efficiency η_{mot} %	Rated current I_N A	Rated speed n_N rpm	Maximum speed n_{max} rpm	Maximum frequency f_{max} Hz
2.2	ER71C-6DY.F7.1R	163664/EX41	112M	84.5	5.29	960	920	48
3.0	ER71C-6DY.G7.1R	163665/EX41	132S/M	85.6	6.93	970	1050	54
4.0	ER71C-6DY.H7.1R	130554/EX41	132M/S	86.8	9.11	965	1140	59
5.5	ER71C-6DY.H7.1R	130555/EX41	132M/S	88.0	12.90	970	1280	66
7.5	ER71C-4DY.H7.1R	130556/EX41	132M/S	90.4	14.30	1465	1380	47
11.0	ER71C-4DY.I7.1R	130557/EX41	160M/L	91.6	20.90	1470	1620	55
15.0	ER71C-4DY.K7.1R	130558/EX41	160L/M	92.3	27.90	1470	1760	60
18.5	ER71C-4DY.L7.1R	130559/EX41	180M/L	92.6	35.20	1470	1840	63

P_N kW	Type	Weight kg	T mm	T1 mm	T3 mm	T4 mm	H2 mm	Flexible connector	Guard grille	Vibration damper		Frequency inverters 3~
										Spring	Rubber	
2.2	ER71C-6DY.F7.1R	174.00	885	864	630	115	752	00406434	00412708	02006449	00090157	308234
3.0	ER71C-6DY.G7.1R	203.00	885	912	735	115	772	00406434	00412708	02006450	00090157	308234
4.0	ER71C-6DY.H7.1R	217.00	885	912	735	115	772	00406434	00412708	02006450	00090157	308265
5.5	ER71C-6DY.H7.1R	217.00	885	912	735	115	772	00406434	00412708	02006450	00090157	308265
7.5	ER71C-4DY.H7.1R	209.00	885	912	735	115	772	00406434	00412708	02006450	00090157	308267
11.0	ER71C-4DY.I7.1R	308.00	1045	1075	893	115	893	00406434	00412708	02006450	00090157	308323
15.0	ER71C-4DY.K7.1R	308.00	1045	1075	788	115	893	00406434	00412708	02006450	02000407	308325
18.5	ER71C-4DY.L7.1R	363.00	1045	1110	893	115	913	00406434	00412708	02006451	02000407	308327