



*Submersible Wastewater Pump*

# OM2/OMA2

**Compact, light and highly efficient**

## Compact yet rugged

Made in a rugged, stainless steel (304) and FRP resin structure, it is compact, light, and corrosion and rust-resistant.

## Space-saving

This automatic model uses a cylindrical float, allowing it to be installed in tight spaces. It also uses an electronic switch that adopts a Tsurumi proprietary TRIAC, enabling stable ON-OFF switching.



## ■ Applications

- Drainage of spring water and rain water from basements
- Sump and floor sump drainage
- Garden water scenic features such as waterfalls and fountains
- Treated water in small-scale sewage purifications systems



**OM2**



**OMA2**  
(automatic)



**Amenics**  
Amenities from Technology  
for People and The Earth

## ■ Features

### A Automatic motor protection device

If something causes the motor windings to abnormally heat or an overcurrent to flow, the built-in automatic motor protection device automatically detects this to shut off circuits.

### B Air-release valve

This valve is made of resin in an integrated structure with the casing to prevent air lock.

### C Dual-inside mechanical seal

With the dual-inside mechanical seal, both seal faces are lubricated in the oil chamber, and are lubricated and cooled by lubricating oil. As seals are not lubricated by pump fed fluids as in an outboard type, trouble caused by corrosion of metal parts or internal accumulation of debris is eliminated.

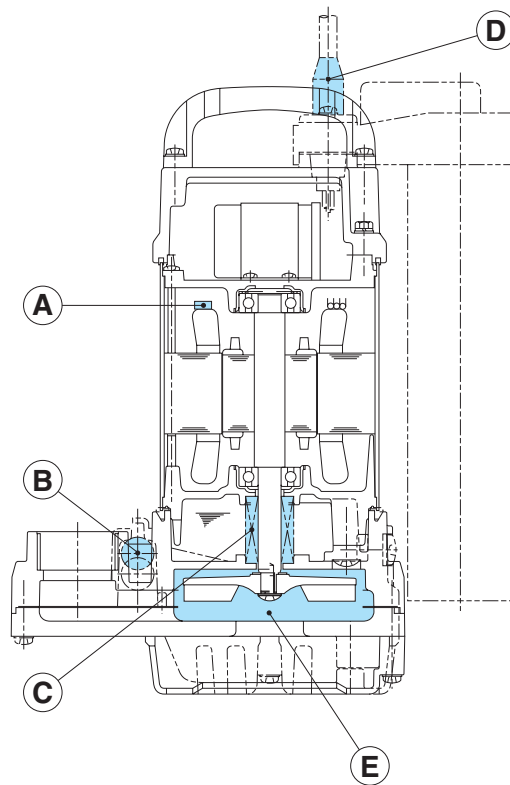

### D Anti-wicking cable entry

An anti-wicking block is provided at the cable entry section to the motor chamber. Should the cable jacket become damaged causing the tip of the cable to be immersed in water, ingress of water into the motor is prevented even if water travels along the lead cores by capillary phenomenon.

### E Semi-vortex design

The “high-gap structure” minimizes the generation of “impeller lock” that occurs when mixed in debris is about to impede impeller rotation.

## ■ Dimensions Unit: mm

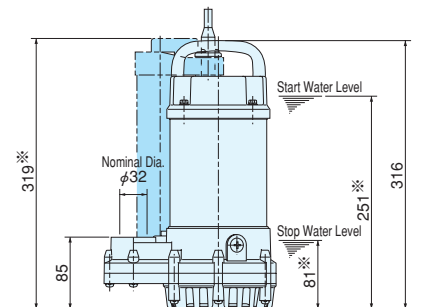
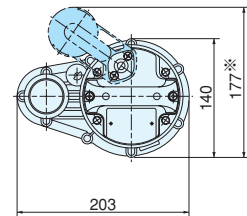

※ Automatic type only

## ■ Performance Curves

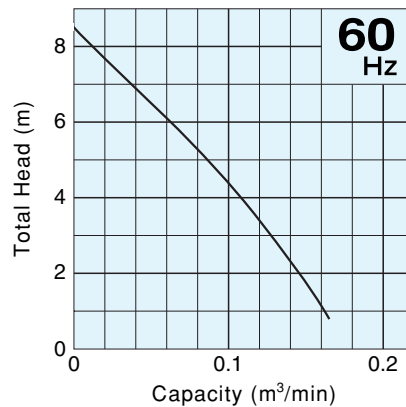
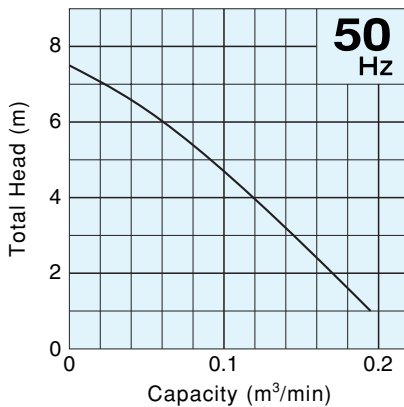

## ■ Specifications 50/60Hz

Model	Discharge Bore mm	Motor Output kW	Phase	Revolution 50Hz/60Hz min <sup>-1</sup>	Starting Method	Max. Head 50Hz/60Hz m	Max. Capacity 50Hz/60Hz m³/min	Impeller Passage mm	Standard Cable Length m	Dry Weight kgs
OM2	32	0.15	Single	3000/3600	Capacitor Run	7.5/8.5	0.195/0.165	10	3	5.9
OMA2 (automatic)	32	0.15	Single	3000/3600	Capacitor Run	7.5/8.5	0.195/0.165	10	3	6.1

● Dry weight of the pump excluding cable.

We reserve the right to change the specifications and designs for improvement without prior notice.

**TSURUMI**  
MANUFACTURING CO.,LTD.

Your Dealer