



*"Grease Guardian lets me
focus only on my job"*

JESSICA SMITH
PASTRY CHEF



MANUAL GREASE TRAP RANGE

Suitable for coffee shops, confectioneries,
snack bars, patisseries and other small
catering applications

Stainless steel fabrication

Intelligent design

Traps food waste & grease

Small foot print and portable

Easy to install and maintain

Full customer support

THREE-STAGE OPERATION SYSTEM

STAGE 1 Solids Collection

Wastewater from the kitchen is directed through the inlet of the **Grease Guardian®** where a removable strainer basket collects any solid debris.

STAGE 2 Grease & Oil Separation

Grease in the wastewater floats to the surface and is trapped while the clear water leaves the unit and enters the drainage system.

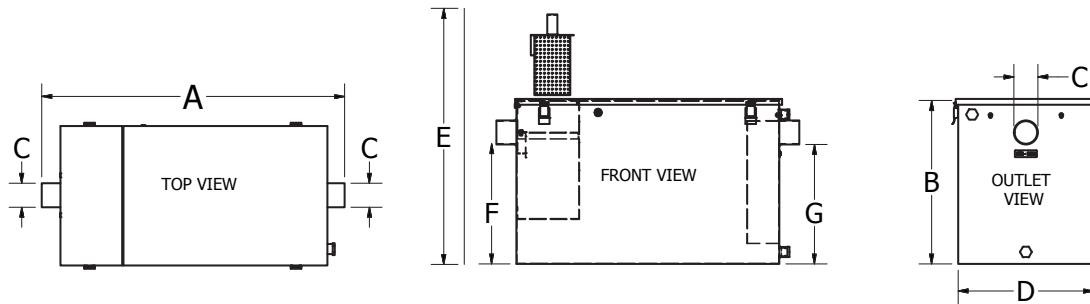

Model	Length (A) <small>INCLUDES CONNECTIONS</small>	Height (B) <small>TANK ONLY</small>	Inlet/Outlet (C)	Width (D)	Basket clearance (E)	Inlet Height (F)	Outlet Height (G)	Max flow (litres/sec)
GT1	700	323	60.1	340	488	205	205	0.75 l/s
GT2	760	395	60.1	340	614	300	300	1.25 l/s
GT3	800	428	60	340	683	340	300	2.00 l/s
GT4	943	455	88.9	360	710	331	231	2.75 l/s
GT5	1000	455	88.9	400	735	331	231	3.5 l/s

ALL DIMENSIONS IN MM

MANUAL GREASE TRAP RANGE WITH FAT-BIO DOSING OPTION

STAGE 3 Dosing (Optional)

The trapped grease can be treated by using the FatBio solution which combines a lipase producing non pathogenic bacteria with nutrients and enzymes.

Fat-Bio Grease Solution

- Unique liquid biological formulation
- Completely bio-degradable with minimal environmental impact
- Complies with (EC) No 648/2004 Regulation
- Product requires no hazard labelling and is therefore safe to transport, to store and to use

