



**ITT**

Water & Wastewater

# Flygt low speed mixers

**Outstanding efficiency**



*Engineered for life*

**motralec**

4 rue Lavoisier . ZA Lavoisier . 95223 HERBLAY CEDEX  
Tel. : 01.39.97.65.10 / Fax. : 01.39.97.68.48  
Demande de prix / e-mail : [service-commercial@motralec.com](mailto:service-commercial@motralec.com)  
[www.motralec.com](http://www.motralec.com)



# Better mixing and reduced power consumption

*Allowing the mixer jet to develop leads to a good bulk flow and efficient mixing of the entire tank.*



Compared to dry-mounted mixers, submersible solutions offer greater flexibility and considerable savings in energy consumption for a wide range of mixing applications, such as solids suspension, bottom erosion, blending, circulation or destratification.

## **How does mixing work?**

All mixing applications require varying degrees of both small-scale turbulence and bulk flow. With a good bulk flow, the contents of the entire tank are put in motion so that all parts are involved in the mixing. Most mixing applications generate abundant turbulence and it is the strength of the bulk flow that controls the efficiency of the mixing. The performance of a submersible mixer is measured by the thrust (N) that it produces. So the strength of the bulk flow is in turn dependent on the total amount of installed thrust.

## **Submersible mixers mean more efficient bulk flow**

Submersible mixers allow a great deal of flexibility in positioning and orientation, unlike their dry-mounted counterparts. The mixer jet can be positioned to develop over a long distance and adapted to the shape of the tank. This ensures the creation of a maximum level of bulk flow. The result: more efficient mixing and lower power consumption.

# Fast, easy installation

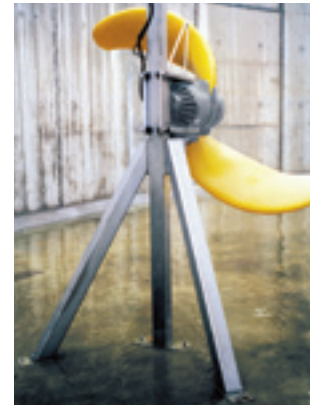

The most frequently-used installation method employed with the Flygt 4400 series mixers is the guide bar with the mixer being easily raised and lowered. This method gives easy accessibility for servicing.

## **The submersible route to lower capital investment**

Using a submersible mixing solution presents a number of cost advantages over traditional dry-mounted mixer alternatives. The installation method is quick and easy and requires low capital investment. A minimum number of units are required to mix very large volumes, thus further reducing the costs associated with the installation.

## **No costly modifications**

Thanks to the flexibility of the installation method, Flygt mixing equipment can be used in existing tanks without the need for expensive alterations to the site.

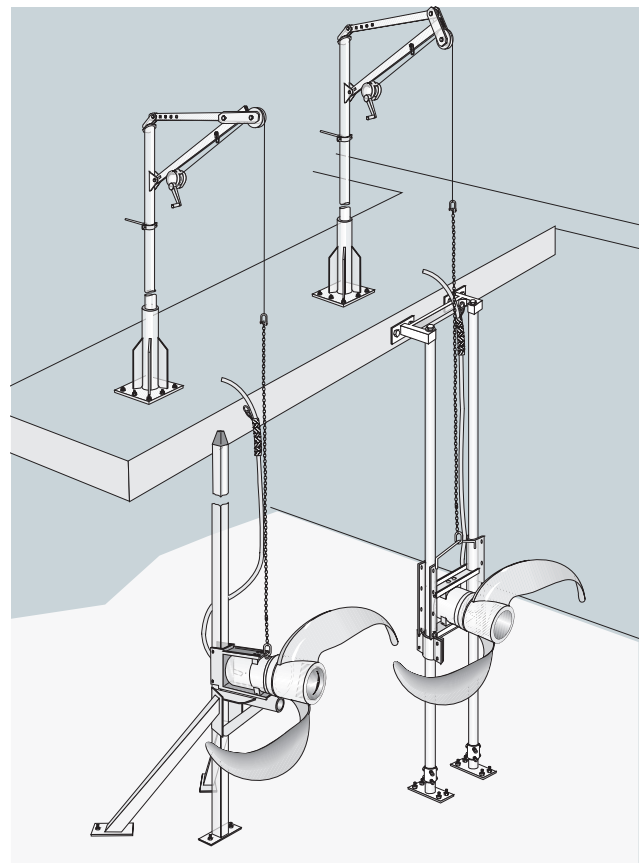

### **Single guide bar system**

*A frequently used solution that eliminates any risk of fatigue, yet provides a cost efficient installation.*

### **Double guide bar system**

*Rigid design that also allows installation of multiple mixers at different depths.*

# Every detail ensures the highest reliability

## Inner shaft seals

Shaft seals between stator and gear box, and between gear box and seal housing.

## Outer shaft seal

Mechanical shaft seal between surrounding liquid and seal housing.

## Propeller

Thin-sectioned, double-curved blades with a unique design for maximum efficiency and clog-free operation.

## Electric motor

Squirrel cage induction motor with thermal overload protection.

## Seal housing

Seal housing containing barrier fluid. This fluid also lubricates and cools the seal.

## Cable entry

Compressible bushing and strain relief on the cable prevent leakage into the motor.

## Gear box

Designed for years of trouble-free operation

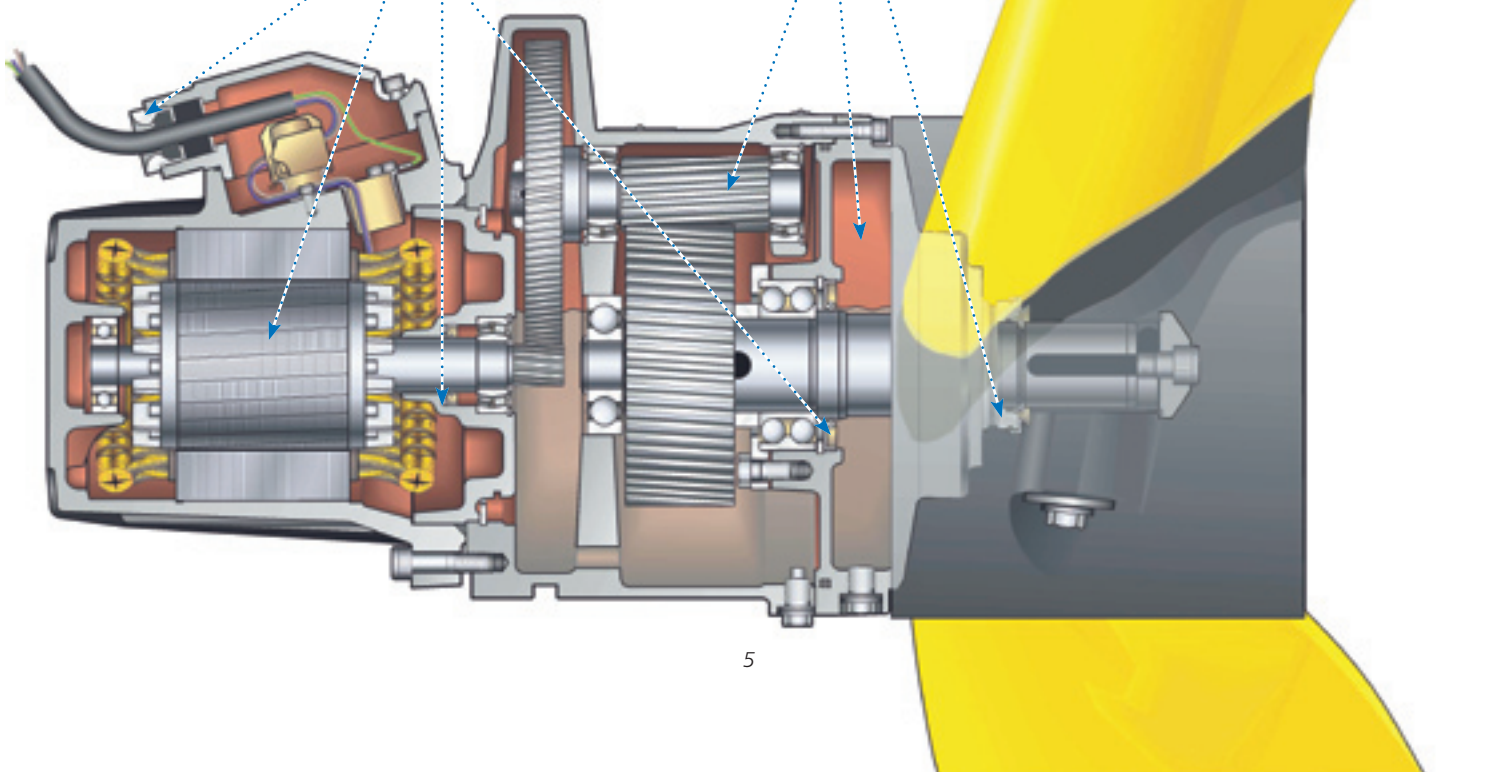

# Maximum efficiency from a unique design

In almost all applications, the mixing result depends on a good bulk flow being generated throughout the tank. In turn, the strength of this bulk flow depends on the thrust of the mixer. The hydraulic efficiency, speed and diameter of the propeller together determine the cost in power consumption of the generated thrust.

## State-of-the-art design

ITT Flygt's low speed mixers combine excellent hydraulic design together with large diameters and low speed. The low speed mixer is therefore the optimum choice for generating the absolute maximum of thrust with the minimum of power consumption.

This efficiency also has to be maintained when operating in fibrous material, where clogging could be a problem. So the swept-back design of Flygt low speed propellers also provides exceptional self-cleaning properties.

The Flygt design solution relies on material bonding technology, employing glass fiber reinforced polyurethane. This results in maximum strength with optimum hydraulic efficiency.

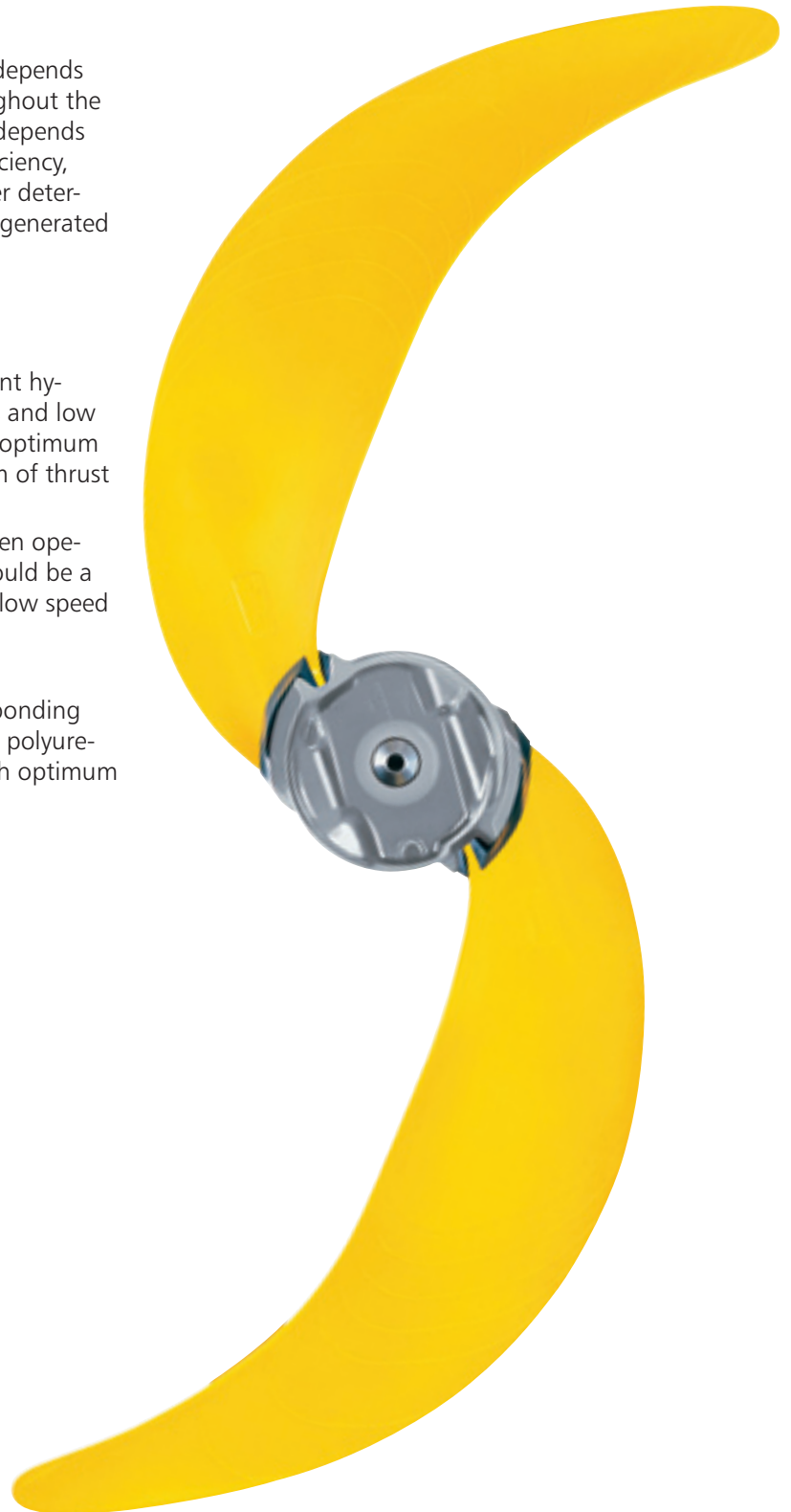

# Seals engineered for the job

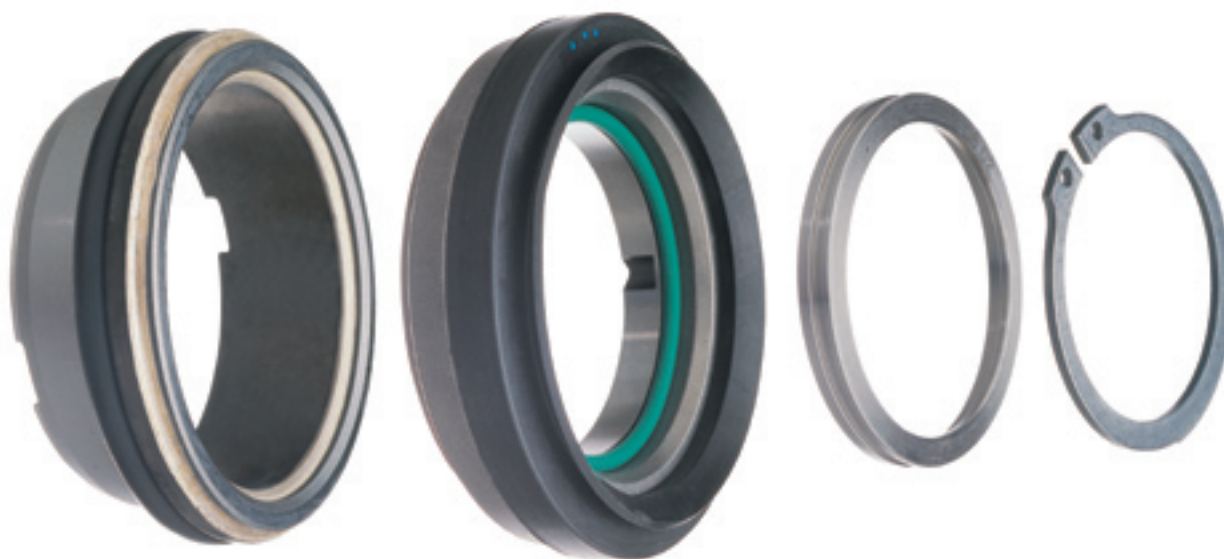

Shaft seals are a crucial component in the reliable operation of any submersible mixer. Flygt 4400 series mixers employ our own unique mechanical shaft seal design with an intermediate barrier fluid.

## Why do seals wear out?

Theoretically, the surfaces of mechanical seals should be constantly divided by a thin film of liquid. In practice, there is always some direct contact which leads to wearing of the seal surfaces. This is why the choice of material, and its sliding properties, is extremely important to the longevity of a mechanical seal.

## The choice for longer life

Flygt low speed mixers are equipped with shaft seals manufactured from corrosion-resistant tungsten carbide (WCCR). Other material choices available include silicon carbide (SiC), but for the kind of applications where Flygt low speed mixers are used, WCCR provides the optimum choice.

The reason can be found in WCCR's superior sliding properties. This factor results in significantly less wear between the two seal surfaces, and thus, offers a longer operational life with less risk of leakage. WCCR also offers better mechanical strength and is far less brittle or prone to handling damage. The addition of a chromium, nickel and molybdenum binder in the material also ensures excellent corrosion resistance down to a pH of 3.

	Bending strength (MPa)	Fracture toughness (MPa <sup>1/2</sup> )
WCCR	2600	18
SiC*	390	4.5

*WCCR has superior mechanical properties.  
\*For materials comparison only*

# Tough coatings that are gentle on the environment

The drive units, including motor and gearbox, of Flygt 4400-series mixers are made of grey cast iron. To prevent corrosion in varying applications, a resistant coating is required. In choosing suitable coatings, great care has been taken to ensure that any chemicals used do not present a hazard to the environment.

## Standard coating

Where a standard coating is used, the cast iron parts are first blasted and then dipped in a corrosion-preventive primer. The oxiranester top coating is characterised by high mechanical strength and impact resistance, as well as offering good protection against chemicals.

The oxiranester coating also offers environmental advantages during the manufacturing process. Compared with alternative coatings, the emission of solvents and volatile organic compounds is substantially reduced. Oxiranester does not pose a risk of cancer and does not promote allergies.

## Special coating

Applications with chloride levels over 200 ppm, will call for extra corrosion protection. In these cases an alternative coating can be chosen. The standard primer is replaced with a zinc-rich epoxy primer which provides increased anodic corrosion protection. Oxiranester is still used as a top coating because of its excellent properties, but here it is applied in three layers. For further protection in these applications, the mixers may also be equipped with optional zinc anodes.

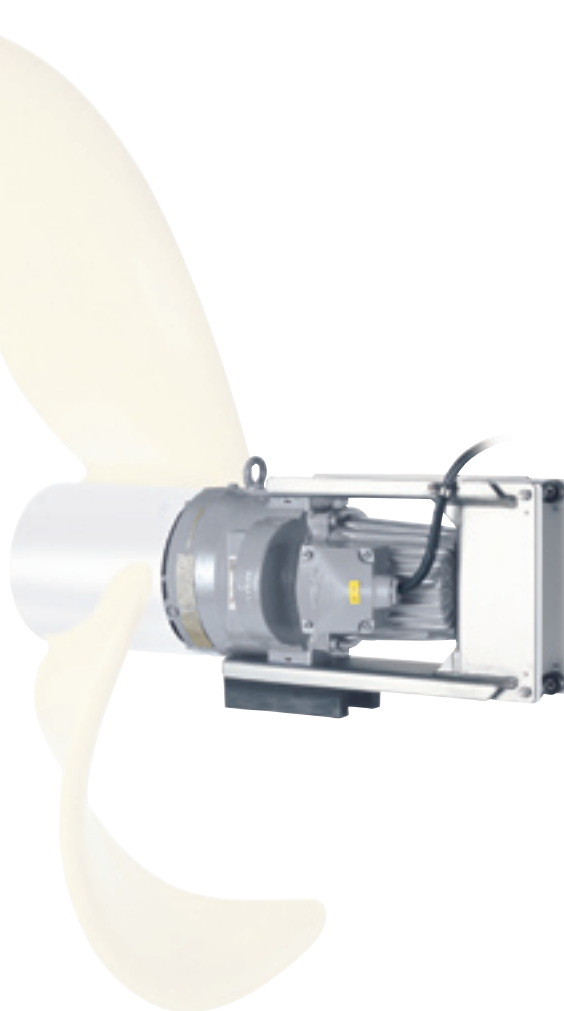

3 layers of top coating

Zinc-rich epoxy primer

Blasted cast iron

*Cross section of Flygt epoxy coating*



# A wide performance range

ITT Flygt conceived the concept of the submersible low speed mixer for gentle mixing of large volumes. Over the years the concept has been developed and perfected, and today the Flygt range of 4410, 4430 and 4460 mixers offer highly energy-efficient solutions for a wide range of mixing applications, such as:

- Biological treatment tanks
- Sludge holding tanks
- Equalisation tanks
- pH stabilisation tanks
- Chemical flocculation
- Water reservoirs
- Ice prevention
- and many more.

## Modular concept

The mixers are available with different motor alternatives. Eight different gear ratios are offered, and propeller diameters range from 1400 mm to 2500 mm (55<sup>1</sup>/<sub>8</sub>" – 98<sup>3</sup>/<sub>8</sub>").

By combining different motors, gear ratios and propeller diameters, the modular design of Flygt low speed mixers allows for a comprehensive selection of mixer performance.

Model	4410	4430	4460
Shaft power	50 Hz, 2.3 kW 60 Hz, 2.6 kW/3.5 hp	50 Hz, 4.3 kW 60 Hz, 4.6 kW/6.2 hp	50 Hz, 5.7 kW 60 Hz, 6.3 kW/8.4 hp
Max. nominal thrust	50 Hz, 2.2 kN 60 Hz, 2.4 kN/530 lb	50 Hz, 3.3 kN 60 Hz, 3.4 kN/760 lb	50 Hz, 4.6 kN 60 Hz, 4.5 kN/1000 lb
Propeller diameter	1400 mm to 2500 mm 55 <sup>1</sup> / <sub>8</sub> " to 98 <sup>3</sup> / <sub>8</sub> "	1400 mm to 2500 mm 55 <sup>1</sup> / <sub>8</sub> " to 98 <sup>3</sup> / <sub>8</sub> "	1400 mm to 2500 mm 55 <sup>1</sup> / <sub>8</sub> " to 98 <sup>3</sup> / <sub>8</sub> "

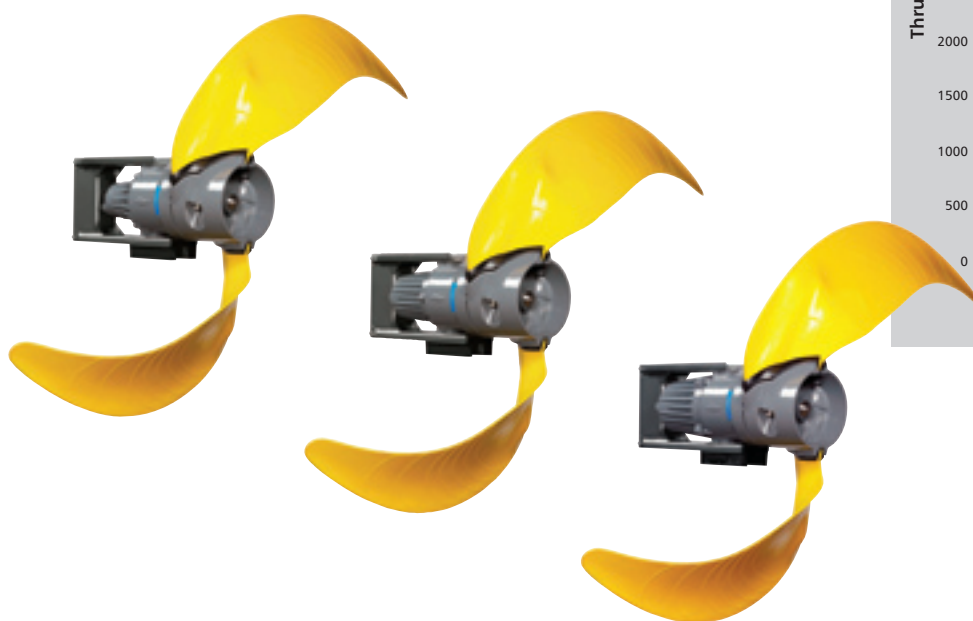
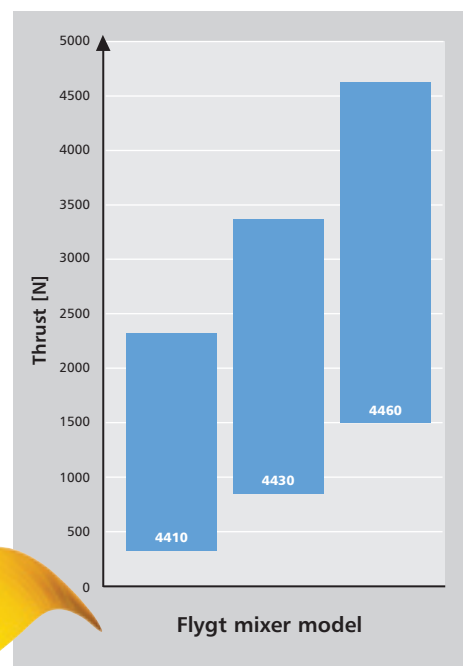

# Making your equipment even easier to work with

Installation accessories should be rigid enough to withstand the weight and reaction forces exerted by the mixer throughout its operating life. Professional operators also need the equipment to be easy to work with for installation as well as inspection and service.

## Well proven reliability

Strong fluctuating forces act on all large diameter mixers. So installed equipment must be capable of withstanding fatigue. Flygt's installation accessories have proven themselves in thousands and thousands of installations.

## Convenient and safe lifting equipment

ITT Flygt provides equipment that enables convenient lifting and handling of mixers.

The safety is guaranteed with the CE marking, the European sign for safety approval.

The lifting davit is mounted in a holder at its lower end which enables easy turning of the davit. To raise the mixer, the davit is fitted with either a winch or a pulley block.

To reduce investment cost, one davit can be used for several mixers. Mixers can be left submerged without being suspended by the lifting wire. A Flygt patented lifting device guarantees the connection to the mixer's lifting bail.



# Trouble-free operation, year after year



## Local service network – worldwide

The service and maintenance of equipment is a key factor in any professional operation. At ITT Flygt we offer an unparalleled worldwide network, so that there is always a professional service centre close to your operations, with fully equipped workshops and trained service engineers.

## Total service concept

Every mixer installation and system is different and so are the levels of service and support that you may require. With ITT Flygt, you can choose the level of service to suit your needs. From simply supplying mixers, to full service assistance and maintenance, ITT Flygt's total service concept means the service you require, on your terms.



## Easier servicing

In the design stages of our mixers, we pay great attention to the ability of offering prompt and easy on-site service. This, in combination with the availability of service kits, means minimum downtime. For customers who wish to service their own mixers, extensive Workshop and Care & Maintenance manuals are available.



## 15-year spare parts guarantee

We guarantee the availability of spare parts for 15 years after the production of a mixer has stopped. Just another way that ITT Flygt guarantees its long-term commitment to its customers.



### What can ITT Water & Wastewater do for you?

Integrated solutions for fluid handling are offered by ITT Water & Wastewater as a world leader in transport and treatment of wastewater. We provide a complete range of water, wastewater and drainage pumps, equipment for monitoring and control, units for primary and secondary biological treatment, products for filtration and disinfection, and related services. ITT Water & Wastewater, headquartered in Sweden, operates in some 140 countries across the world, with own plants in Europe, China and North and South America. The company is wholly owned by the ITT Corporation of White Plains, New York, supplier of advanced technology products and services.



WEDECO



# motralec

4 rue Lavoisier . ZA Lavoisier . 95223 HERBLAY CEDEX

Tel. : 01.39.97.65.10 / Fax. : 01.39.97.68.48

Demande de prix / e-mail : [service-commercial@motralec.com](mailto:service-commercial@motralec.com)

[www.motralec.com](http://www.motralec.com)