



Flygt Submersible Pumps

AVAILABLE FOR RENTAL AND SALE



www.motralec.com / service-commercial@motralec.com / 01.39.97.65.10

NS 3127

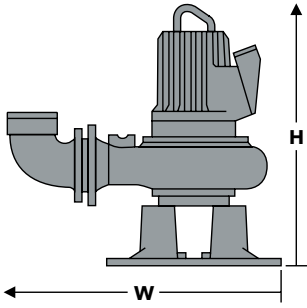

Model number: 3127.185
 Motor rating: 1ø: 7.5HP@1730 RPM
 3ø: 10HP@1740 RPM
 Voltage (1ø): 230V
 Full load amps: 30A
 Voltage (3ø): 200V 230V 460V 575V
 Full load amps: 29A 26A 13A 10A
 Versions: 4" & 8" Standard
 Imp. Code 420 (1ø), 438 (3ø)
 8" High volume
 Imp. Code 422 (1ø), 421 (3ø)
 4" High head
 Imp. Code 489 (1ø), 488 (3ø)
 Hose connection: 4" & 6" NPSM threaded, or slip-on
 4", 6" & 8" Slip-on
 Pump dimensions: 31 1/2" W (max.) x 30 3/4" H (max.)
 Max. weight (lbs.): 400
 Description: Cast iron construction; semi-open, backswept multi-vane, self-cleaning impeller; rests on stand.
 Options: Explosion proof (FM approved) variant 3127.095
 Warm liquid version available

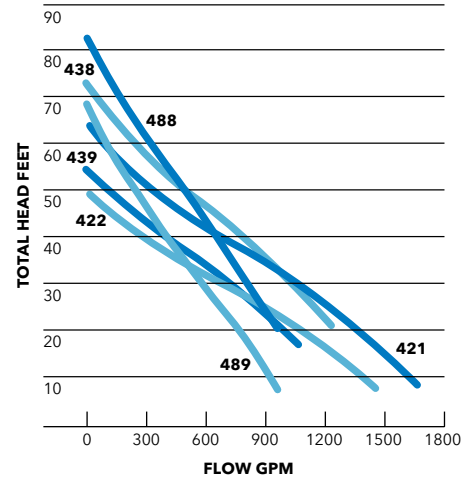

NS 3153

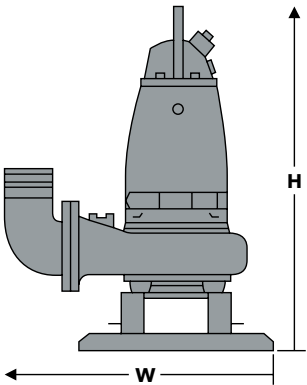

Model number: 3153.185
 Motor rating: 20HP@1755 RPM
 23HP@3510 RPM
 Voltage (3ø): 200V 230V 460V 575V
 Full load amps: 59A 52A 26A 21A
 Versions: 4" Super high head, Imp. Code 274
 4" High head, Imp. Code 461
 6" Standard, Imp. Code 433
 8" High volume, Imp. Code 413
 Hose connection: 4", 6" & 8" Slip-on
 Pump dimensions: 42" W (max.) x 47 1/4" H (max.)
 Max. weight (lbs.): 840 - High volume, 530 - Standard
 Description: Cast iron construction; semi-open, backswept multi-vane, self-cleaning impeller; rests on stand.
 Options: Explosion proof (FM approved) variant 3153.095

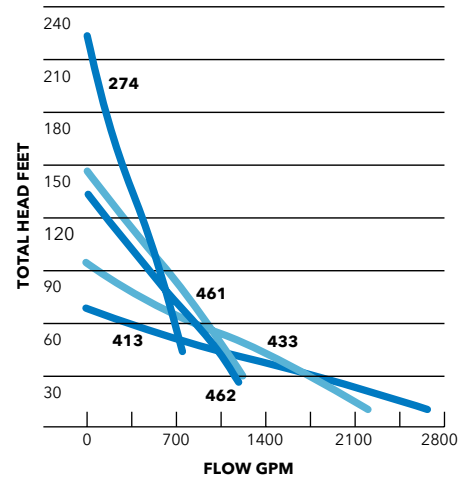

NS 3171

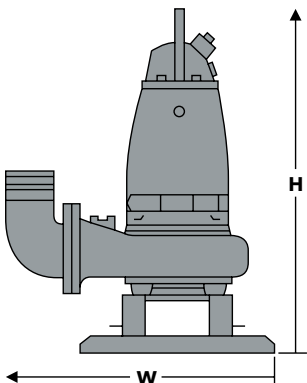

Model number: 3171.185
 Motor rating: 25HP@1160 RPM
 30HP@1740 RPM
 Voltage (3ø): 230V 460V
 Full load amps: 64/74 32/37
 575V
 25/30/31A
 Versions: 6" Standard, Imp. Code 435
 10" High volume, Imp. Code 613
 Hose connection: 6" & 10" Slip-on
 Pump dimensions: 45 1/2" W (max.) x 51 1/4" H (max.)
 Max. weight (lbs.): 1060 - High volume, 770 - Standard
 Description: Cast iron construction; semi-open, backswept multi-vane, self-cleaning impeller; rests on stand.
 Options: Explosion proof (FM approved) variant 3171.095

