

MP 3127 HT 3~ 255
Technical specification

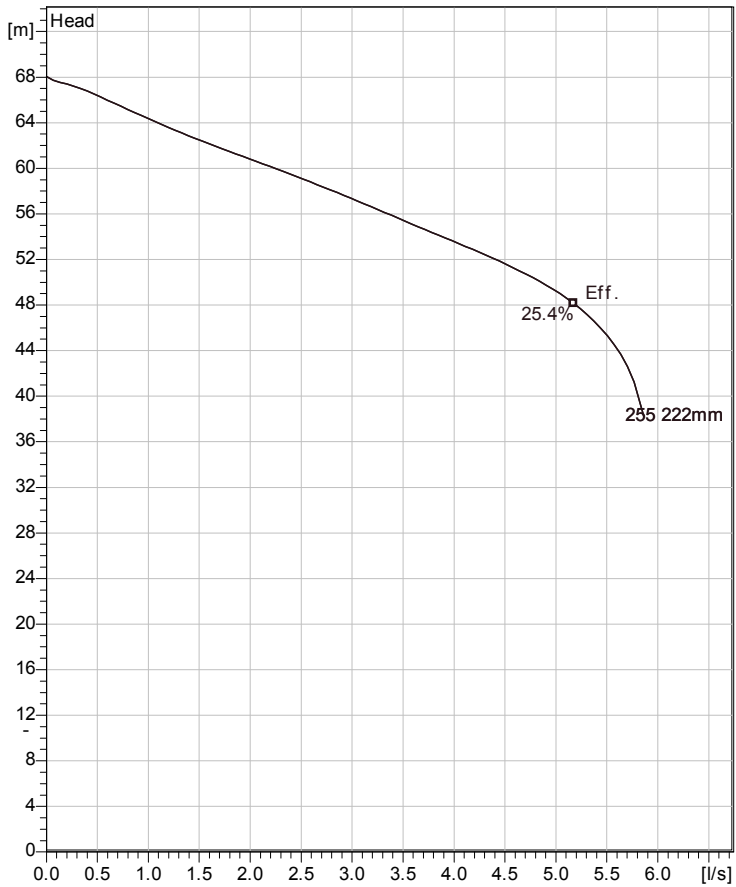

Curve according to: ISO 9906



Note: Picture might not correspond to the current configuration.

General

Semi-open multi-channel impellers with integral grinder cutter in single volute casing for liquids containing solids and fibres.

Impeller

Impeller material	Grey cast iron
Outlet width	50 mm
Inlet diameter	80 mm
Impeller diameter	222 mm
Number of blades	6

Motor

Motor #	M3127.170 21-11-2AL-W 10,9KW
Stator variant	
Frequency	50 Hz
Rated voltage	415 V
Number of poles	2
Phases	3~
Rated power	10.9 kW
Rated current	21 A
Starting current	143 A
Rated speed	2885 rpm
Power factor	
1/1 Load	0.86
3/4 Load	0.82
1/2 Load	0.73
Efficiency	
1/1 Load	83.5 %
3/4 Load	84.5 %
1/2 Load	83.0 %

Configuration

Installation: P - Semi permanent, Wet

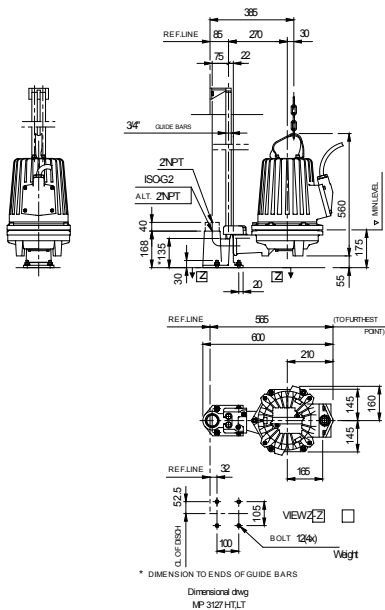

Project	Project ID	Created by	Created on 2012-10-25	Last update
---------	------------	------------	---------------------------------	-------------



MP 3127 HT 3~ 255

Performance curve

Pump

Outlet width	50 mm
Inlet diameter	80 mm
Impeller diameter	222 mm
Number of blades	6

Motor

Motor #	M3127.170 21-11-2AL-W 10,9KW
Stator variant	
Frequency	50 Hz
Rated voltage	415 V
Number of poles	2
Phases	3~
Rated power	10.9 kW
Rated current	21 A
Starting current	143 A
Rated speed	2885 rpm

Power factor	
1/1 Load	0.86
3/4 Load	0.82
1/2 Load	0.73
Efficiency	
1/1 Load	83.5 %
3/4 Load	84.5 %
1/2 Load	83.0 %

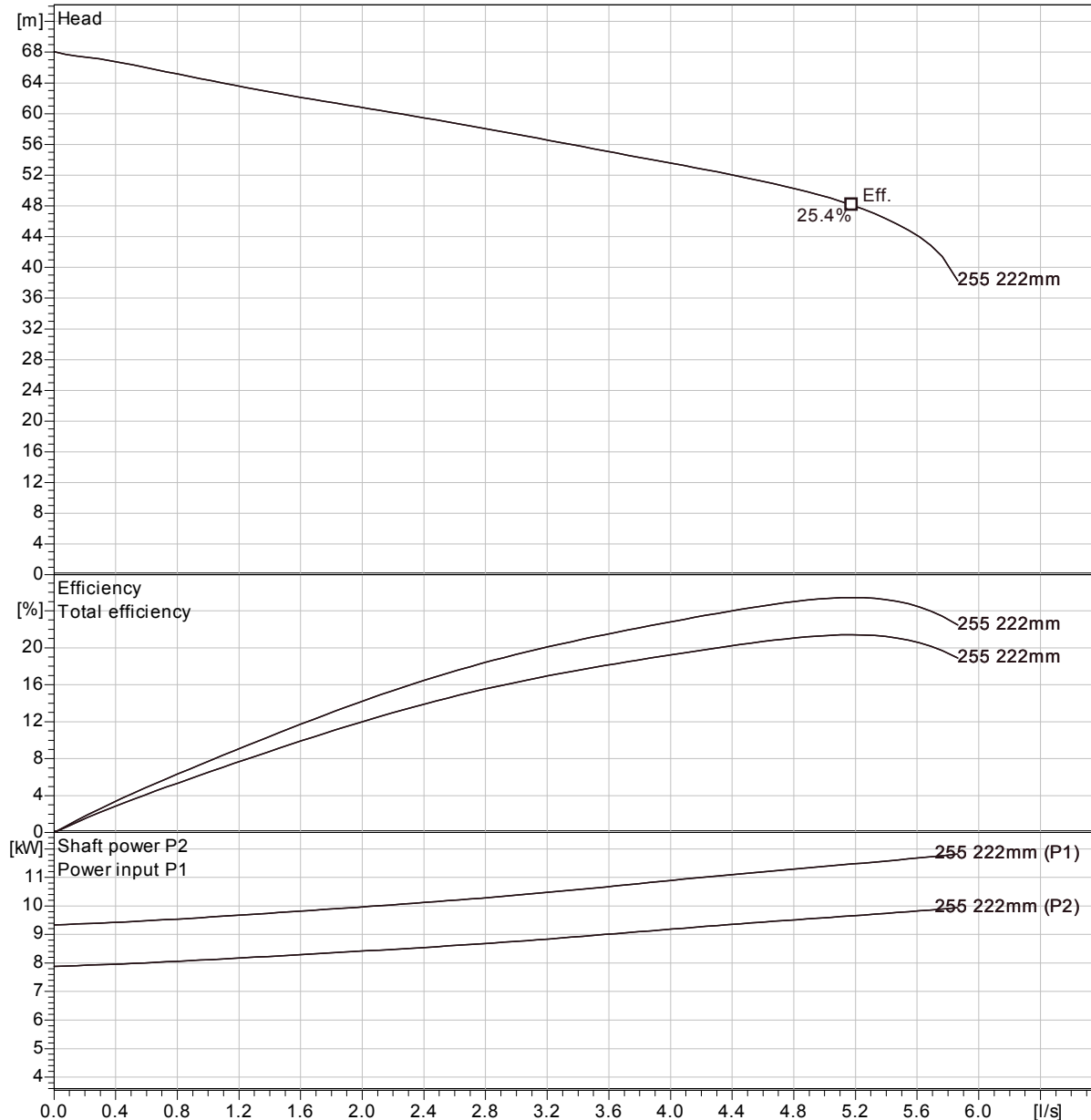

Curve according to: ISO 9906

Project	Project ID	Created by	Created on 2012-10-25	Last update
---------	------------	------------	---------------------------------	-------------

MP 3127 HT 3~ 255
Duty Analysis

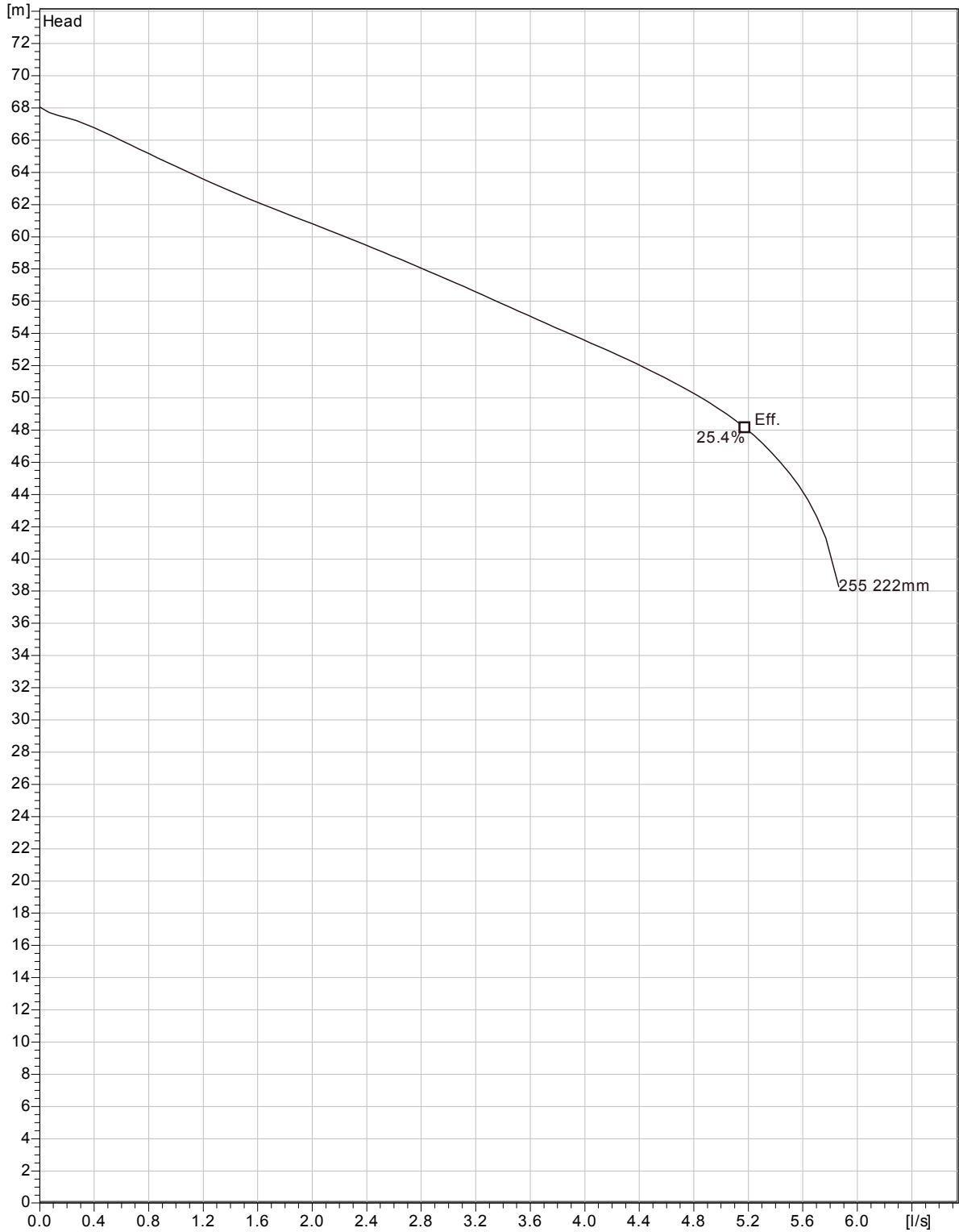

Curve according to: ISO 9906

Project	Project ID	Created by	Created on 2012-10-25	Last update
---------	------------	------------	---------------------------------	-------------

MP 3127 HT 3~ 255
VFD Curve

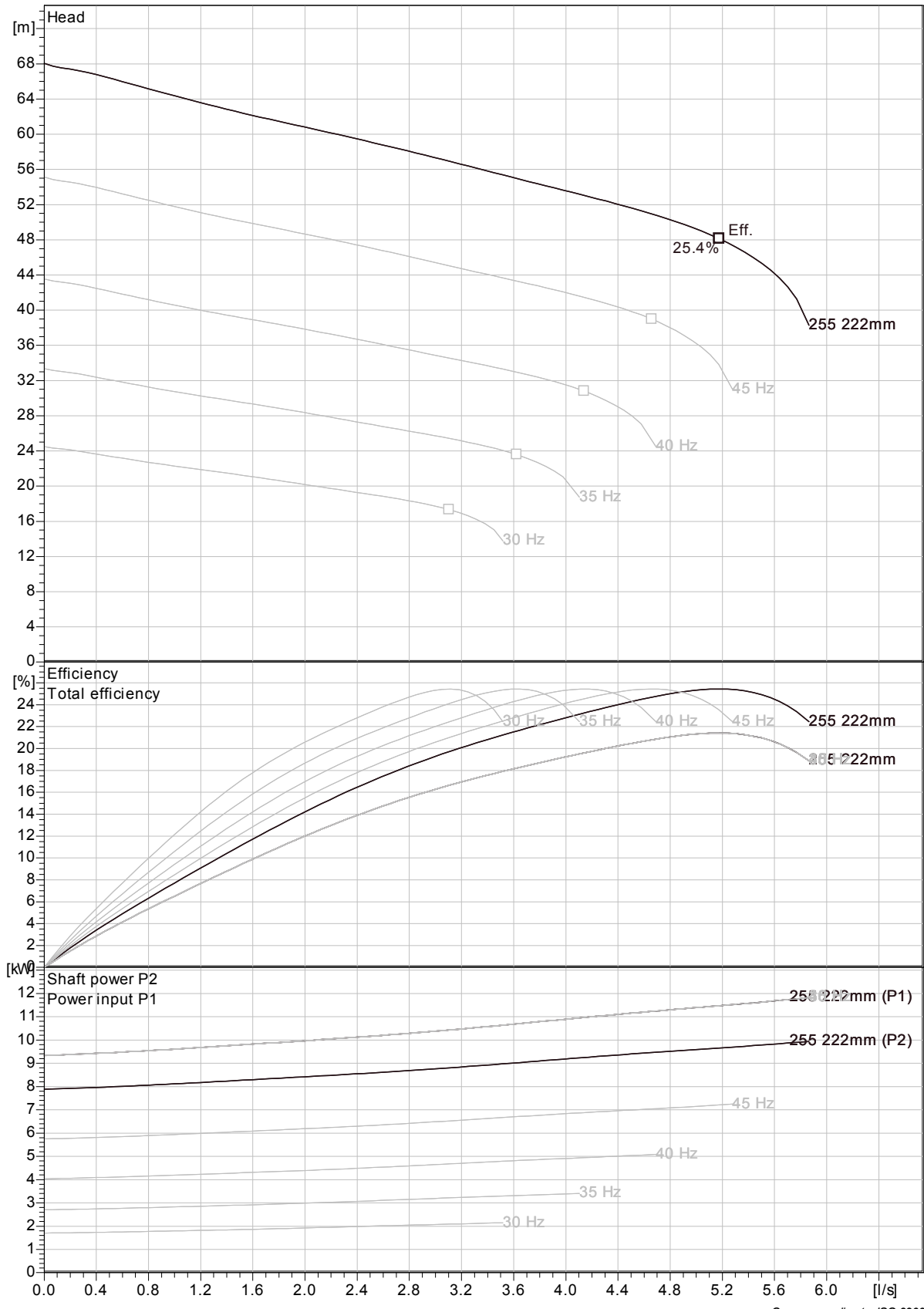

Curve according to: ISO 9906

Project	Project ID	Created by	Created on	Last update
			2012-10-25	



MP 3127 HT 3~ 255
VFD Analysis

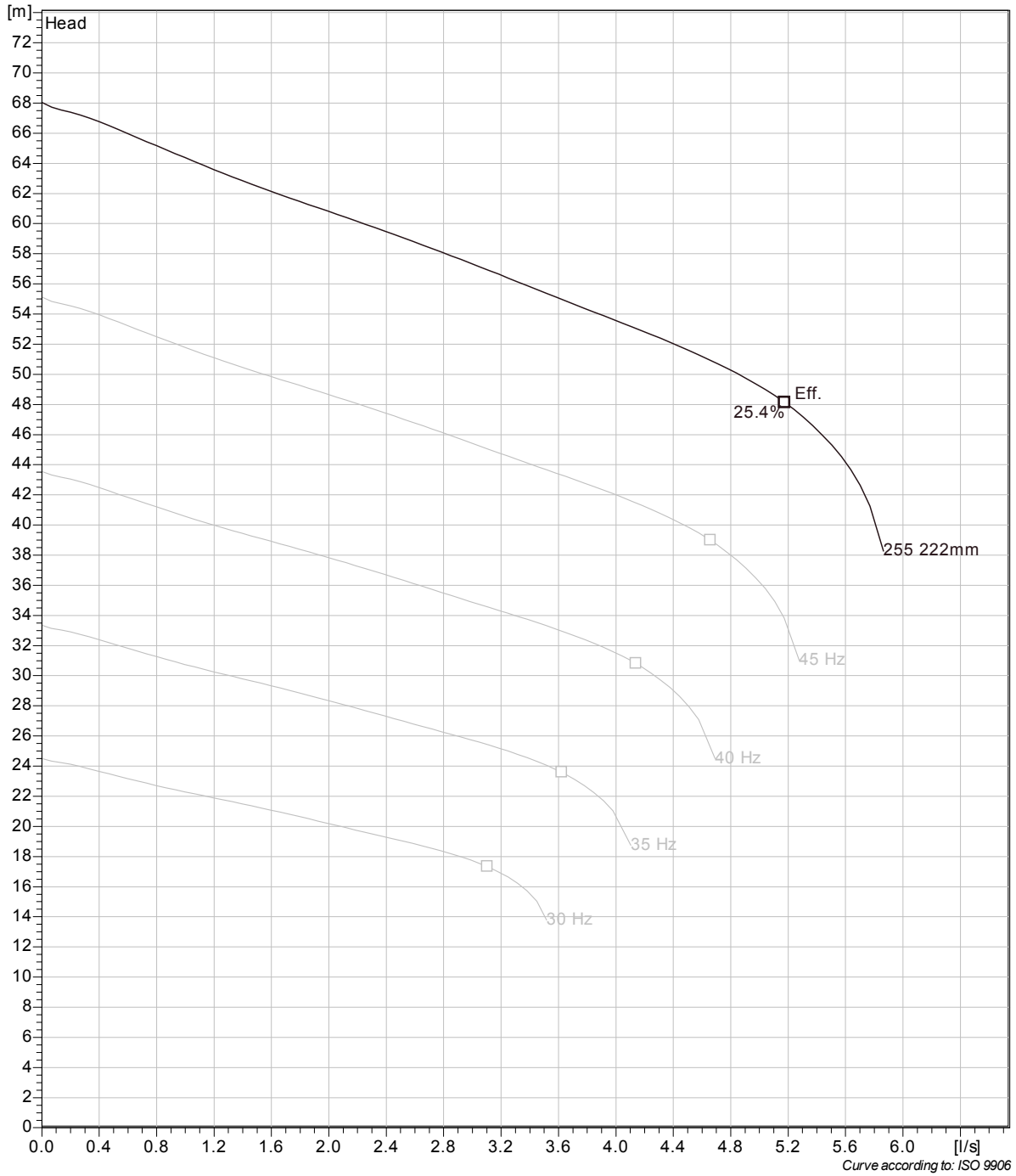

Project	Project ID	Created by	Created on	Last update
			2012-10-25	

MP 3127 HT 3~ 255
Dimensional drawing

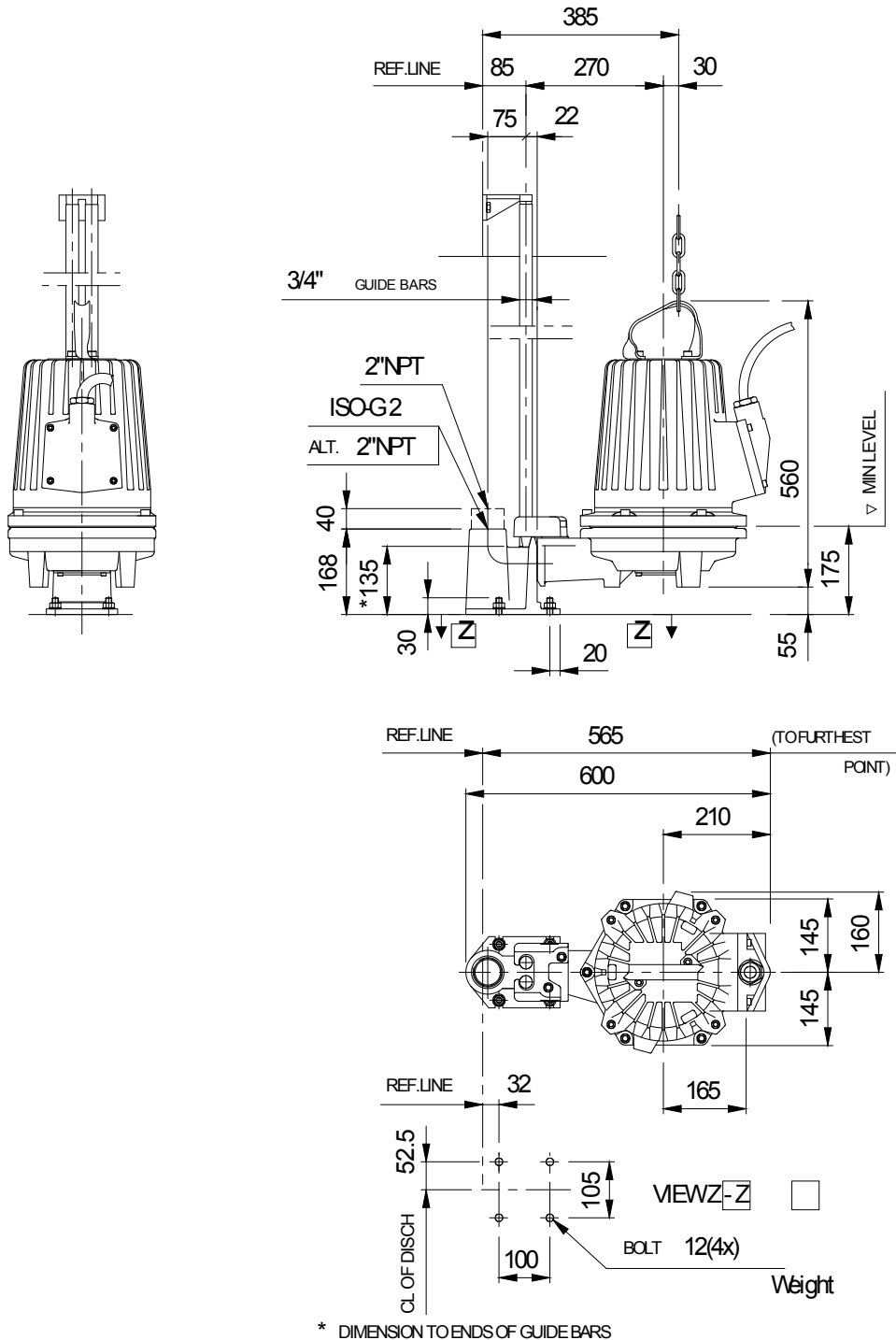

Dimensional dvg
MP3127HT,LT

Project	Project ID	Created by	Created on	Last update
			2012-10-25	