

L-PUMPS • 50 Hz

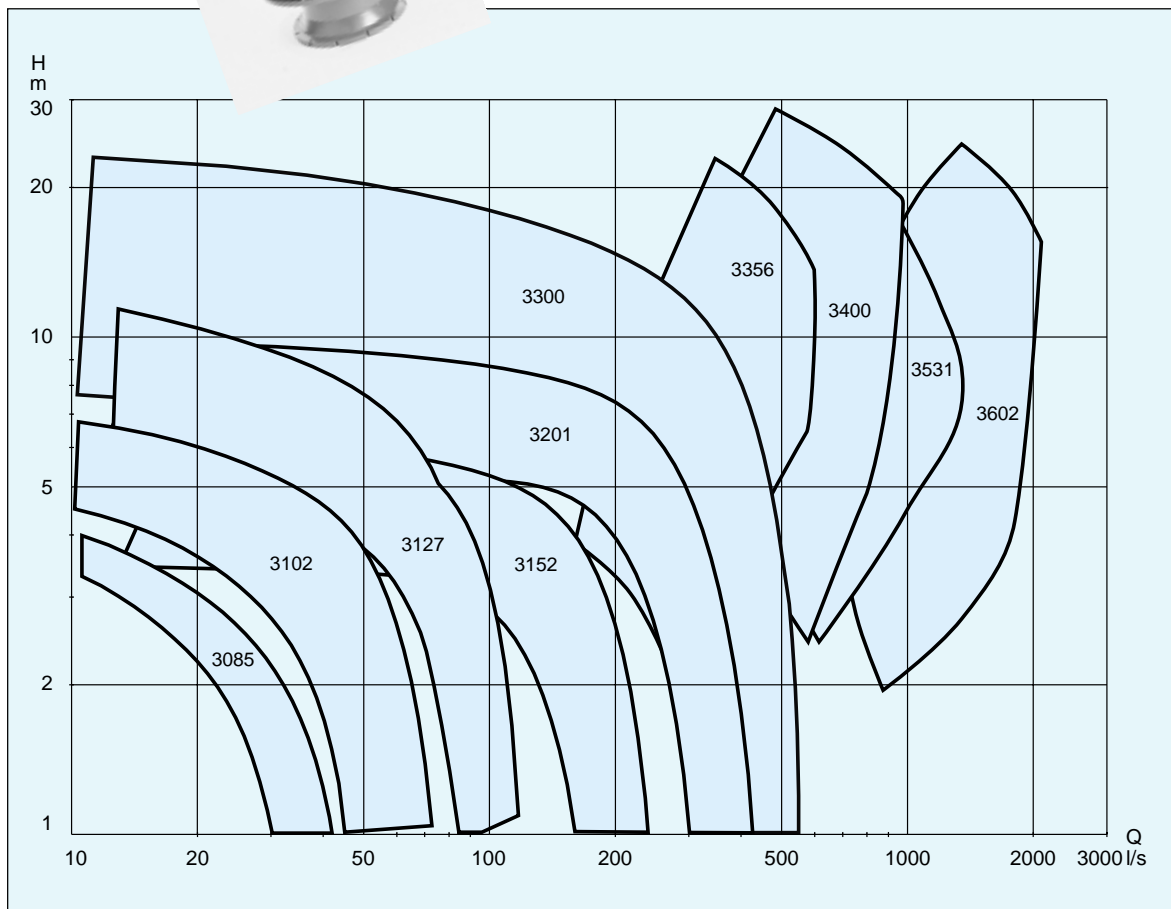

The L-pump's impeller is a shrouded channel impeller in a volute with guide vanes. The guide-vane section leads the rotating water outward and upward on the outside of the pump. L-pumps are mainly used in sewage-treatment plants and in such applications as storm-water pumping, irrigation and drainage.



L 3085

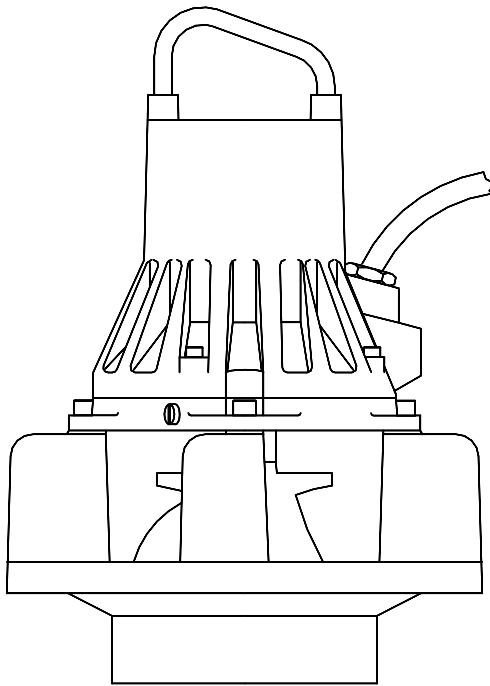

Pump type	L
Weight, kg	75

L

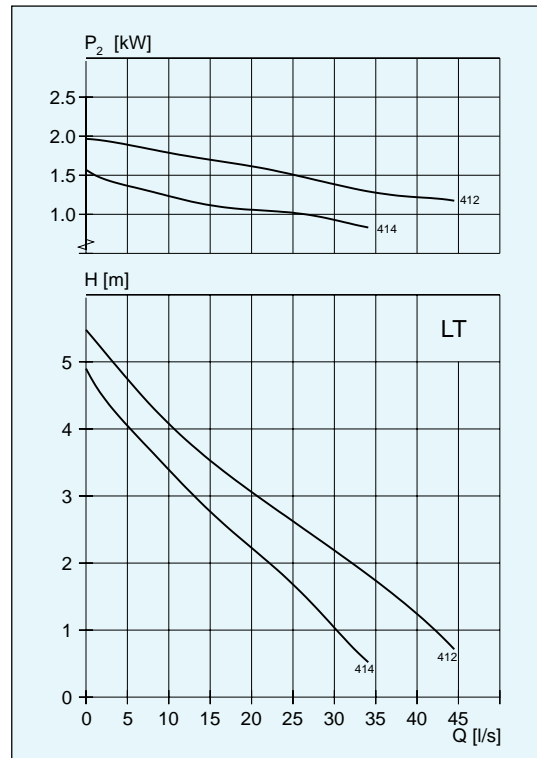

Impeller code	Overall dia mm diffuser ring	Motor rating, kW		rpm
		P_1	P_2	
W412	∅ 380	2.7	2.0	1385
W414	∅ 380	2.7	2.0	1395

L 3102

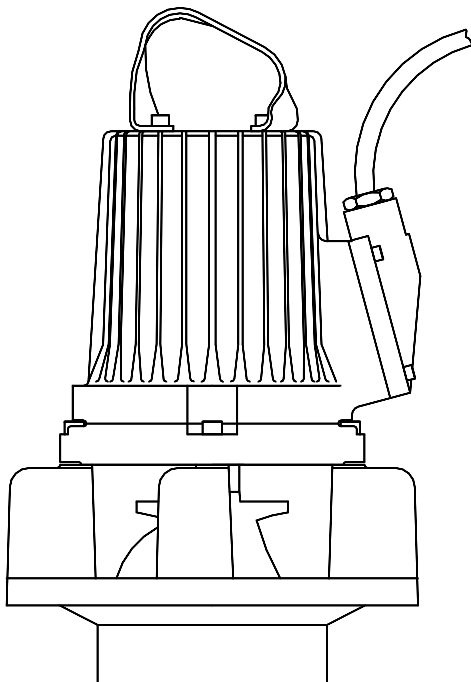

Pump type	L
Weight, kg	95

L

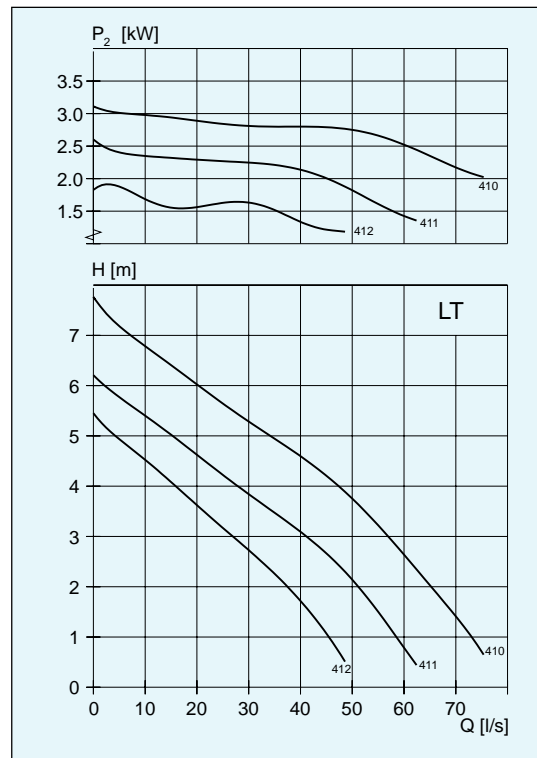

Impeller code	Overall dia mm diffuser ring	Motor rating, kW		rpm
		P_1	P_2	
W410	∅ 380	3.8	3.1	1435
W411	∅ 380	3.8	3.1	1435
W412	∅ 380	3.8	3.1	1435

NL 3102

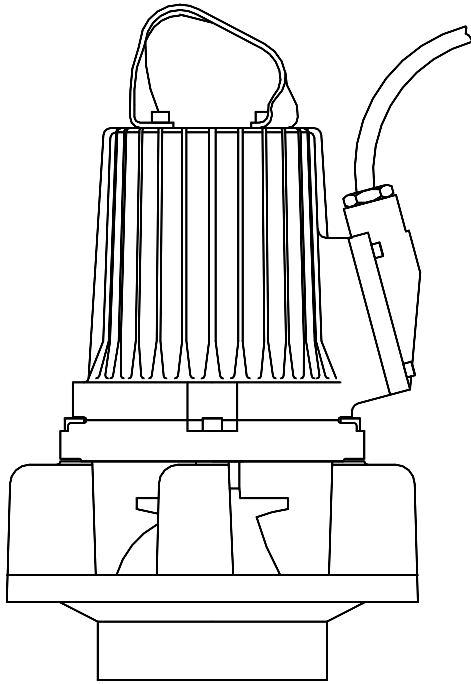

Pump type	NL
Weight, kg	99

NL

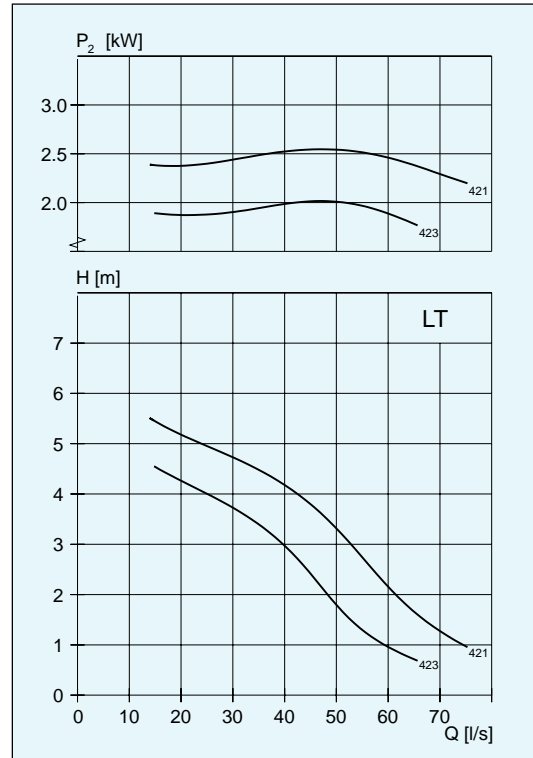

Impeller code	Overall dia mm diffuser ring	Motor rating, kW		rpm
		P ₁	P ₂	
W421	∅380	3.8	3.1	1435
W423	∅380	3.8	3.1	1435

L 3127

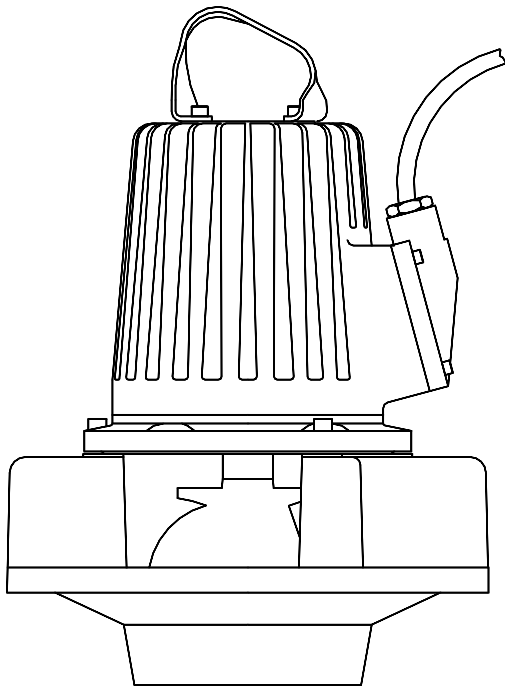

Pump type	L
Weight, kg	133

L

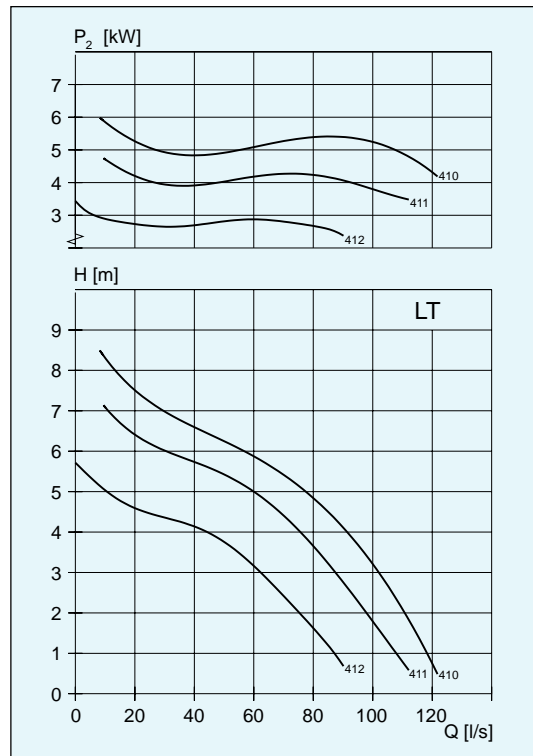

Impeller code	Overall dia mm diffuser ring	Motor rating, kW		rpm
		P ₁	P ₂	
W410	∅480	7.1	5.9	1445
W411	∅480	7.1	5.9	1445
411	∅480	5.7	4.7	1445
W412	∅480	7.1	5.9	1445
412	∅480	5.7	4.7	1445

NL 3127

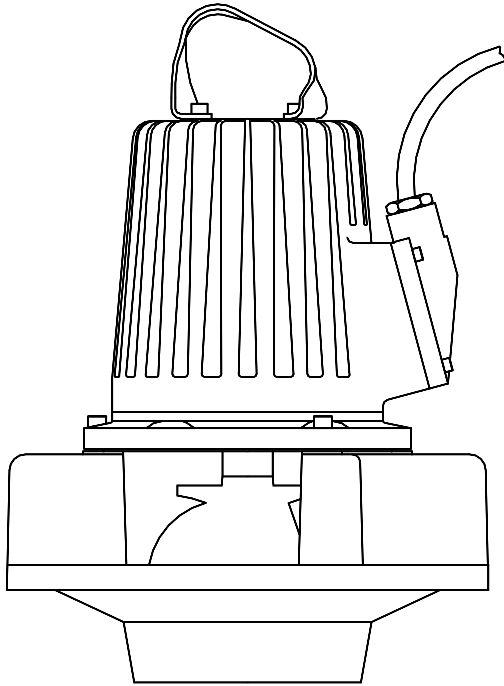

Pump type	NL
Weight, kg	140

NL

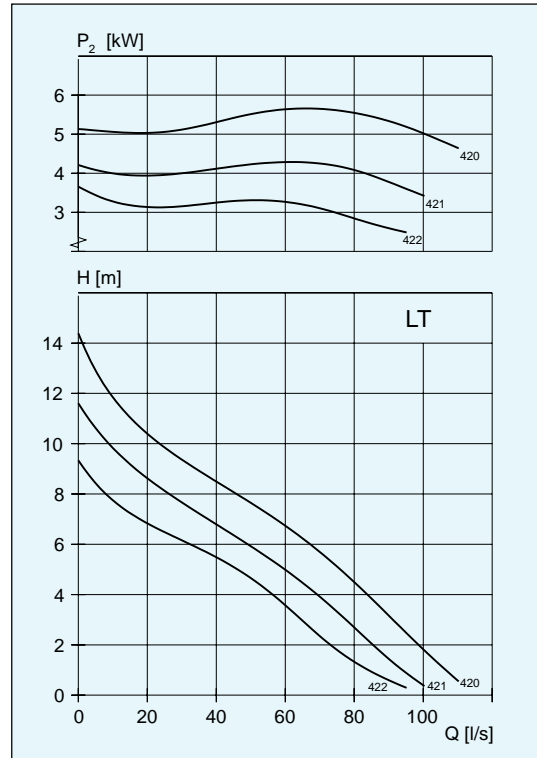

Impeller code	Overall dia mm diffuser ring	Motor rating, kW		rpm
		P ₁	P ₂	
W420	∅480	7.1	5.9	1445
W421	∅480	7.1	5.9	1445
421	∅480	5.7	4.7	1445
W422	∅480	7.1	5.9	1445
422	∅480	5.7	4.7	1445

L 3152

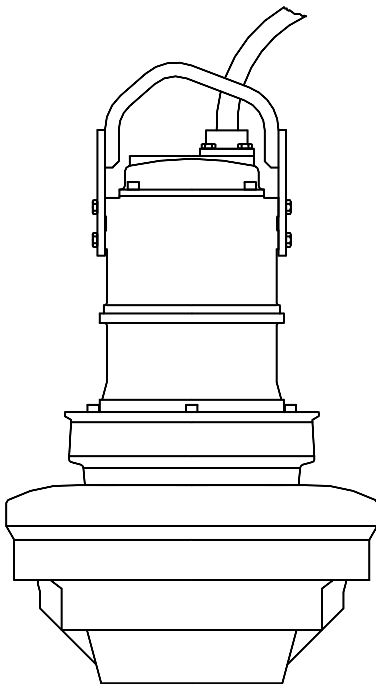

Pump type	L
Weight, kg	264

L

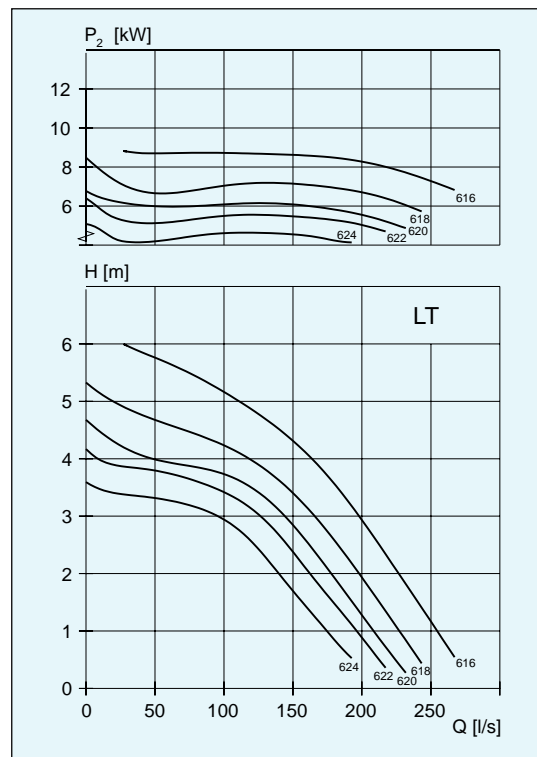

Impeller code	Overall dia mm diffuser ring	Motor rating, kW		rpm
		P ₁	P ₂	
W616*	∅590	10.5	8.8	960
W618*	∅590	10.5	8.8	960
W620	∅590	10.5	8.8	960
W622	∅590	10.5	8.8	960
W624	∅590	10.5	8.8	960

* NPSH_e = 11 m at 235 l/s

L 3201

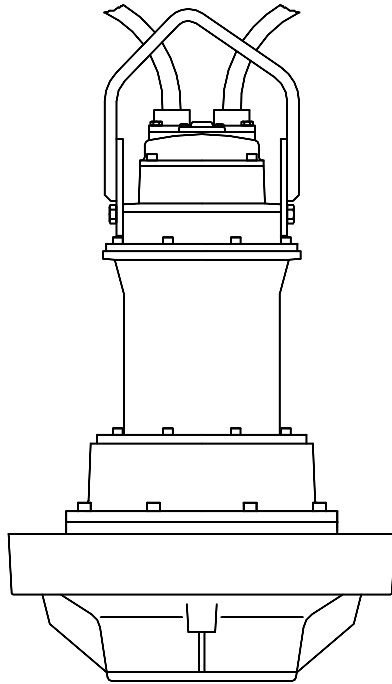

Pump type	L
Weight, kg	450

L

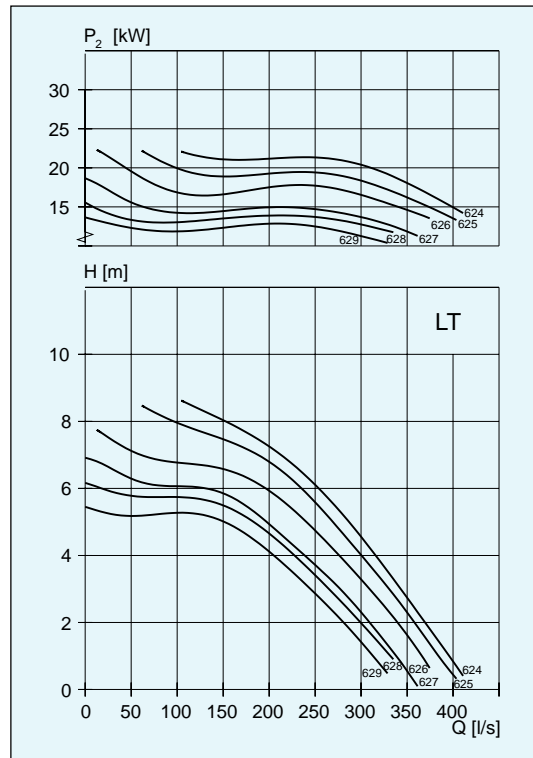

Impeller code	Overall dia mm diffuser ring	Motor rating, kW		rpm
		P ₁	P ₂	
W624	∅ 720	25	22	970
W625	∅ 720	25	22	970
W626	∅ 720	25	22	970
W627	∅ 720	25	22	970
W628	∅ 720	25	22	970
W629	∅ 720	25	22	970

L 3300

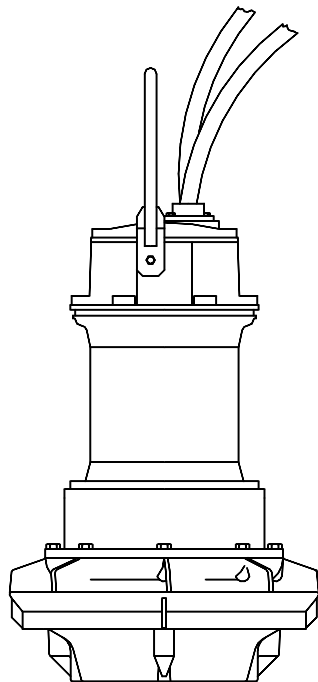

Pump type	L
Weight, kg	750

L

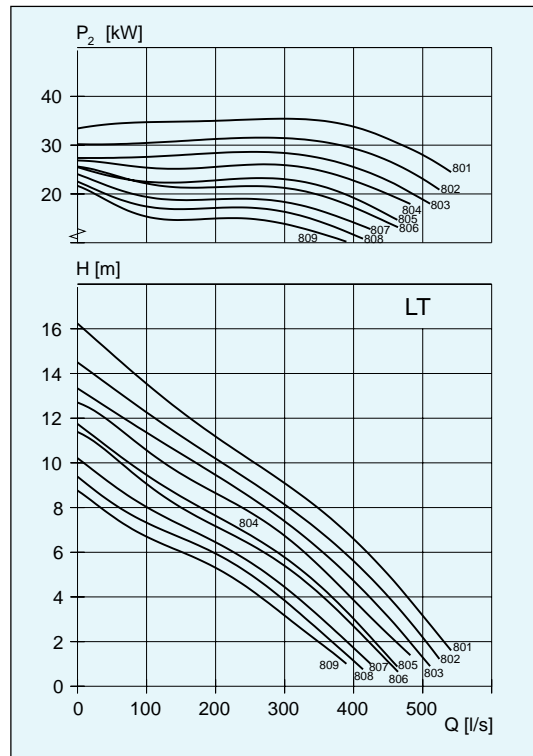

Impeller code	Overall dia mm diffuser ring	Motor rating, kW		rpm
		P ₁	P ₂	
801-809	∅ 780	37	37	730
804-809	∅ 780	31	27	730

NL 3300

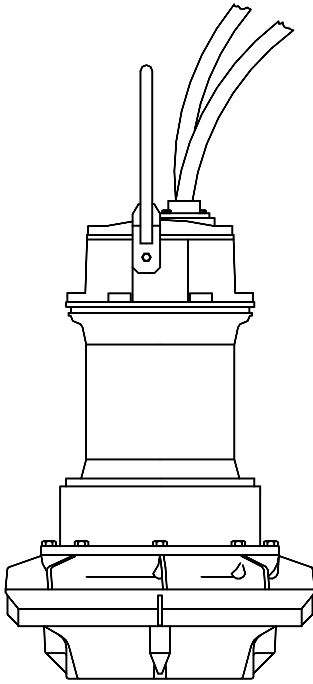

Pump type	NL
Weight, kg	755

NL

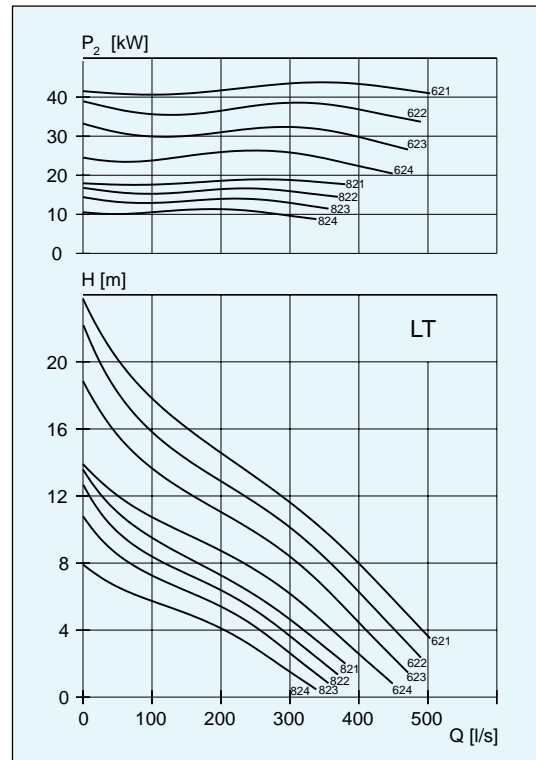

Impeller code	Overall dia mm diffuser ring	Motor rating, kW		rpm
		P ₁	P ₂	
621-624	∅ 800	50	44	975
623-624	∅ 800	39	34	975
821-824	∅ 800	43	37	730
821-824	∅ 800	31	27	730

L 3356

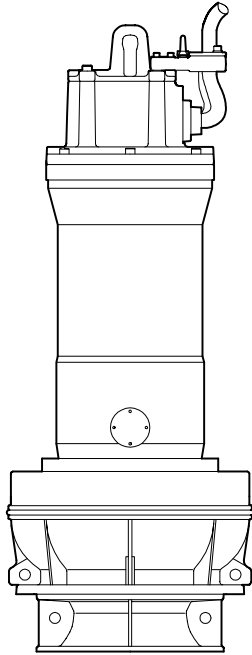

LL

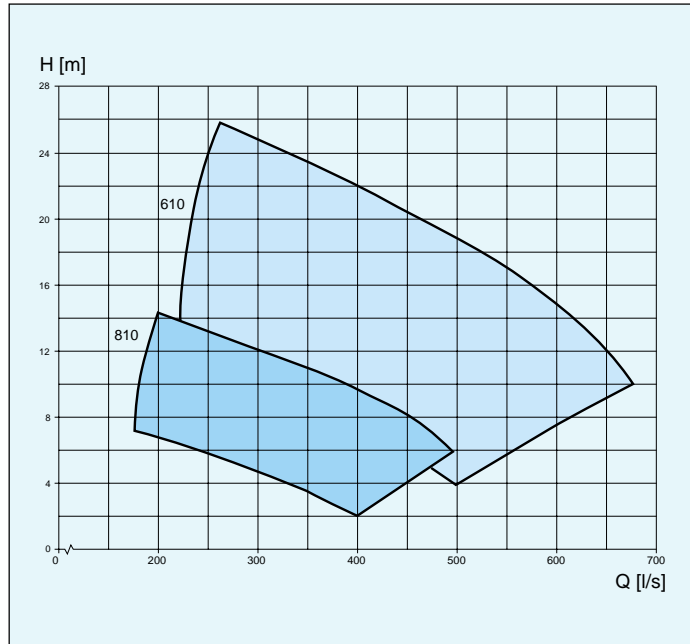

Pump type	L
Weight, kg	1040-1900

Impeller code	Overall dia mm diffuser ring	Motor rating, kW		rpm
		P ₁	P ₂	
610	∅ 785	64-173	58-160	990
810	∅ 785	51-61	45-55	740

L 3400

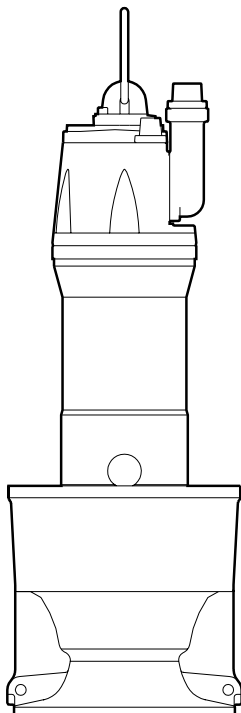

LL

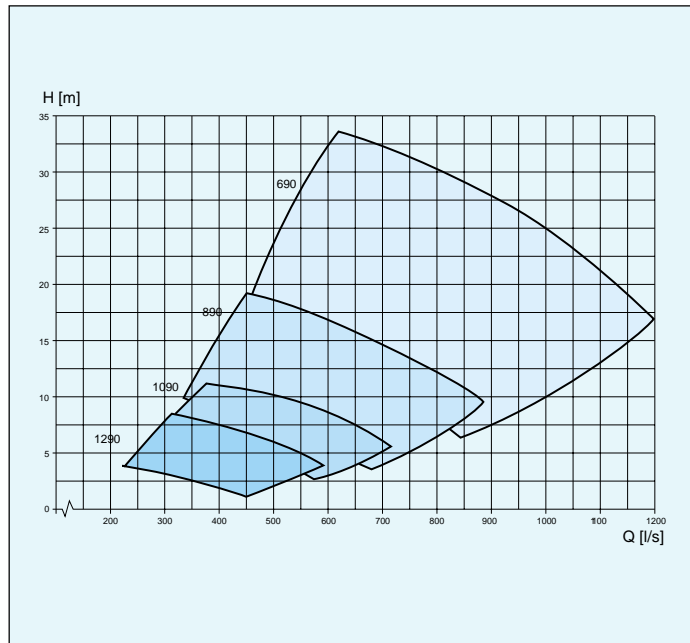

Pump type	L
Weight, kg	1650-3350

Impeller code	Overall dia mm diffuser ring	Motor rating, kW		rpm
		P ₁	P ₂	
690	∅ 860	213-359	200-340	990
890	∅ 860	100-155	90-140	735
1090	∅ 860	44-79	40-70	585
1290	∅ 860	34-51	30-45	490

L 3531

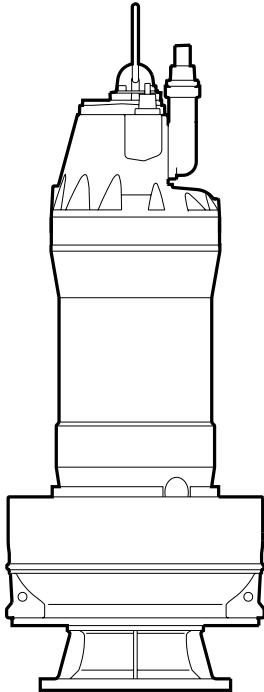

LL

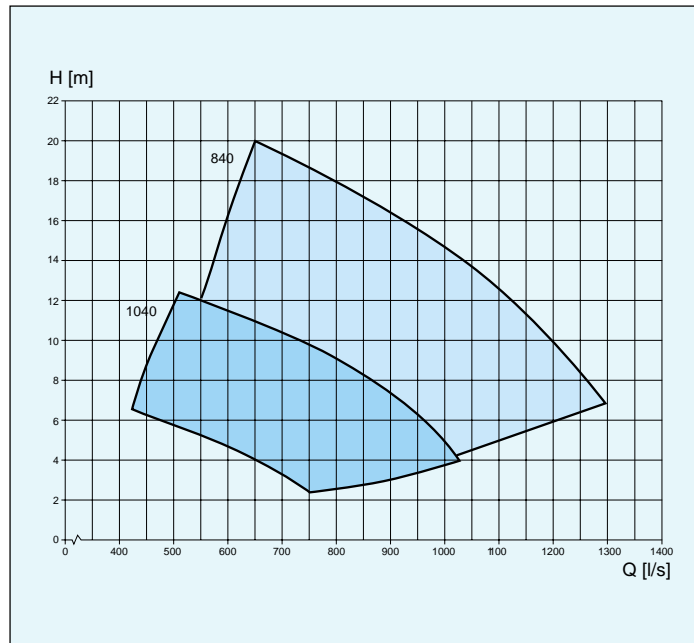

Pump type	L
Weight, kg	2300-4200

Impeller code	Overall dia mm diffuser ring	Motor rating, kW		rpm
		P ₁	P ₂	
840	∅ 1160	111-246	100-230	745
1040	∅ 1160	79-137	70-125	595

L 3602

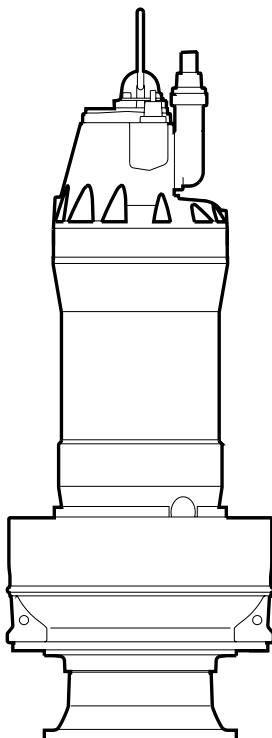

LL

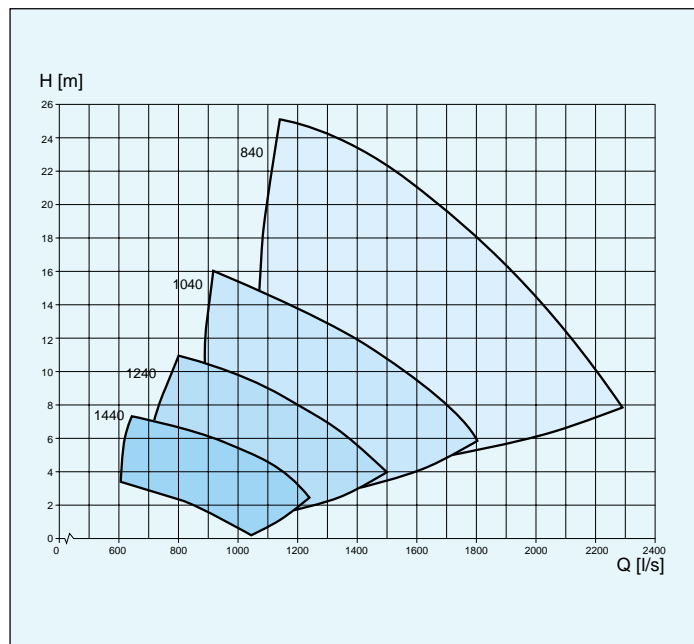

Pump type	L
Weight, kg	2550-4300

Impeller code	Overall dia mm diffuser ring	Motor rating, kW		rpm
		P ₁	P ₂	
840	∅ 1160	246-449	230-430	745
1040	∅ 1160	111-268	100-250	595
1240	∅ 1160	67-174	60-160	495
1440	∅ 1160	46-79	40-70	420