

Technical
specification

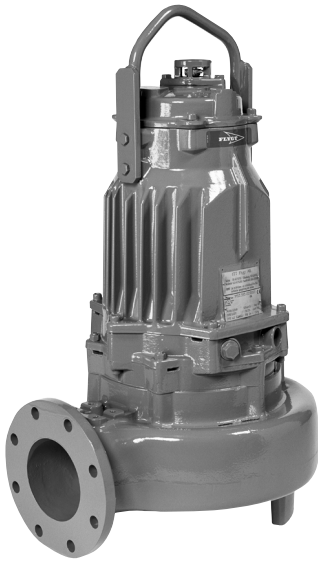

Submersible pump F 3152, 50 Hz

FLYGT
a xylem brand



F 3152

Product

Submersible pump for pumping liquid manure, or heavily contaminated sewage and sludge. The impeller is S-shaped and fitted with a cutting device. The pump is equipped with a friction clutch to protect the pump if any solids is blocking the impeller.

Denomination

Product code	3152.350
Installation	J, P, S
Impeller characteristics	LT, HT

Process data

Liquid temperature	max +40 °C
Depth of immersion	max 20 m
The pH of the pumped liquid	pH 5,5-14
Liquid density	max. 1100 kg/m ³

Motor data

Frequency	50 Hz
Insulation class	H (+180 °C)
Voltage variation	
- continuously running	max ± 5%
- intermittent running	max ± 10%
Voltage imbalance between phases	max 2%
No. of starts/hour	max 30

Cable

Direct-on-line start	
SUBCAB®	4G4+2x1,5 mm ²
	4G6+2x1,5 mm ²
	4G10+2x1,5 mm ²

Y/D start

SUBCAB®	7G2,5+2x1,5 mm ²
	7G4+2x1,5 mm ²
	7G6+2x1,5 mm ²

Monitoring equipment

Thermal contacts opening temperature	125 °C
--------------------------------------	--------

Material

Impeller	Cast iron
Pump housing	Cast iron
Stator housing	Cast iron
Shaft	Stainless steel
O-rings	Nitrile rubber

Mechanical face seals

Alternative	Inner seal	Outer seal
1	Corrosion resistant cemented carbide/ Carbon	Corrosion resistant cemented carbide/ Corrosion resistant cemented carbide
2	Corrosion resistant cemented carbide/ Corrosion resistant cemented carbide	Corrosion resistant cemented carbide/ Corrosion resistant cemented carbide

Surface Treatment

All cast parts are primed with a water-borne primer. The finishing coat is a high-solid two pack paint.

Weight

See dimensional drawing.

Option

Leakage sensor in stator housing	FLS
Leakage sensor in oil housing	CLS
Surface treatment	Epoxy treatment

Other cables

Zinc anodes

Accessories

Discharge connections, hose connections and other mechanical accessories.

Electrical accessories such as pump controller, control panels, starters, monitoring relays, cables.

See separate booklet or www.xyleminc.com, for further information.

LT-Motor rating and performance curve

Curve/Impeller No	Rated power, kW	Rated current, A	Starting current, A	Power factor cos φ	Ex proof version available	Installation			
						J	P	S	
400 V, 50 Hz, 3 ~, 1460 r/min									
492	7,5	16	104	0,81		•	•	•	
400 V, 50 Hz, 3 ~, 955 r/min									
690	8,8	18	87	0,87		•	•	•	
691	8,8	18	87	0,87		•	•	•	
693	8,8	18	87	0,87		•	•	•	
400 V, 50 Hz, 3 ~, 1455 r/min									
491	9,0	19	116	0,81		•	•	•	
492	9,0	19	116	0,81		•	•	•	
400 V, 50 Hz, 3 ~, 1450 r/min									
489	13,5	27	162	0,83		•	•	•	
490	13,5	27	162	0,83		•	•	•	
491	13,5	27	162	0,83		•	•	•	
492	13,5	27	162	0,83		•	•	•	
493	13,5	27	162	0,83		•	•	•	

Y/D starting current is approximately 1/3 of D starting current.

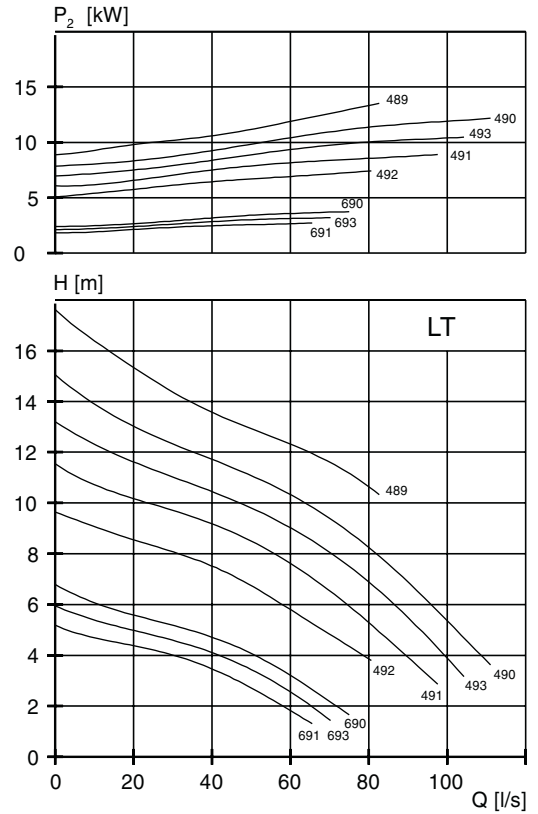

HT-Motor rating and performance curve

Curve/Impeller No	Rated power, kW	Rated current, A	Starting current, A	Power factor cos φ	Ex proof version available	Installation				
						J	P	S		
400 V, 50 Hz, 3 ~, 1460 r/min										
496	7,5	16	104	0,81		•	•	•		
400 V, 50 Hz, 3 ~, 1455 r/min										
495	9,0	19	116	0,81		•	•	•		
496	9,0	19	116	0,81		•	•	•		
400 V, 50 Hz, 3 ~, 1450 r/min										
494	13,5	27	162	0,83		•	•	•		
495	13,5	27	162	0,83		•	•	•		
496	13,5	27	162	0,83		•	•	•		

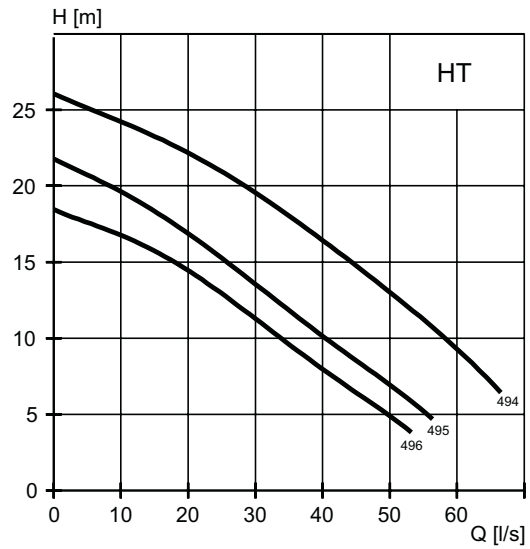
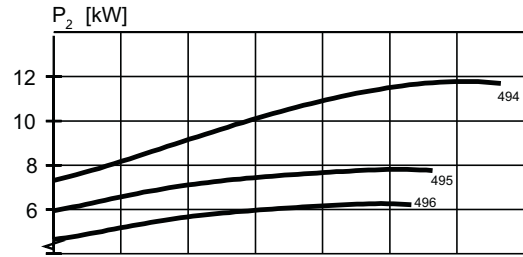

Dimensional drawing

All drawings are available as Acrobat documents (.pdf) and AutoCad drawings (.dwg). Contact your local representative for more information.

All dimensions are in mm.

LT, J-installation

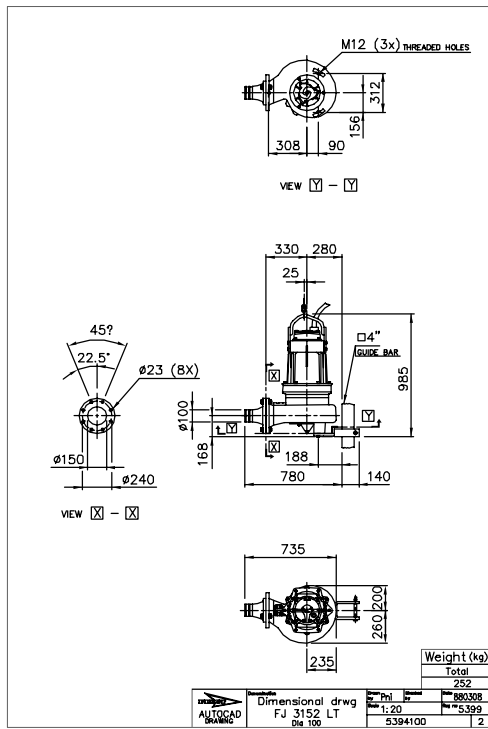

LT, P-installation

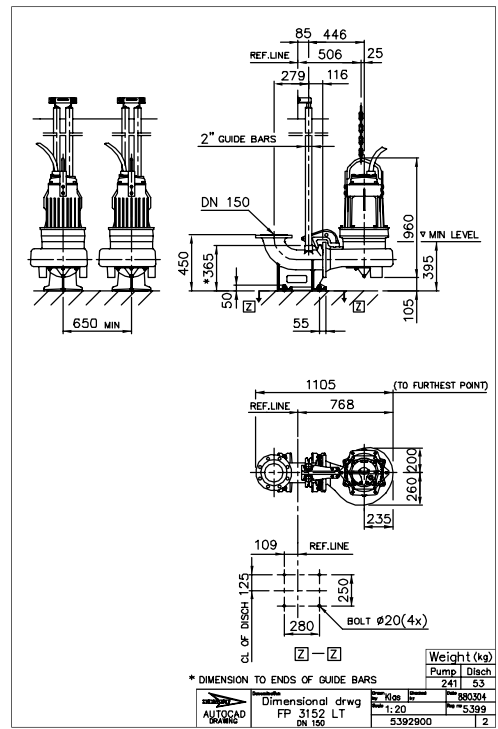

LT, S-installation

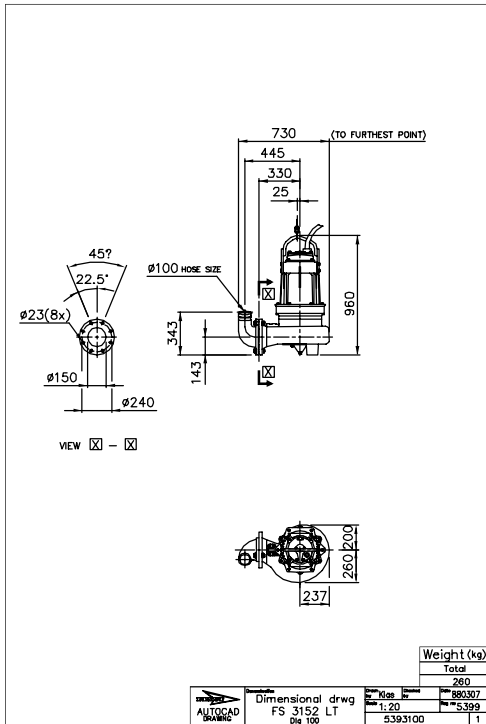

HT, J-installation

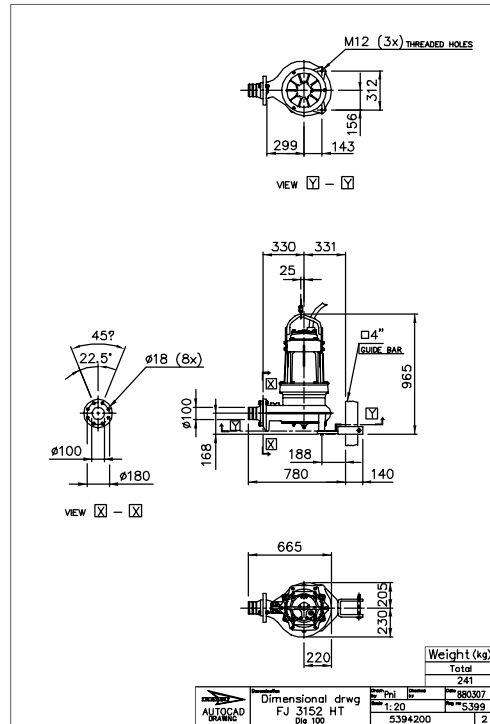

HT, P-installation

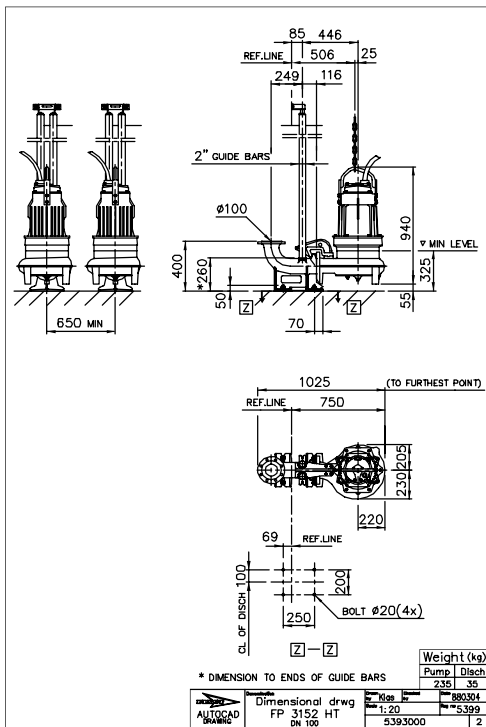

HT, S-installation

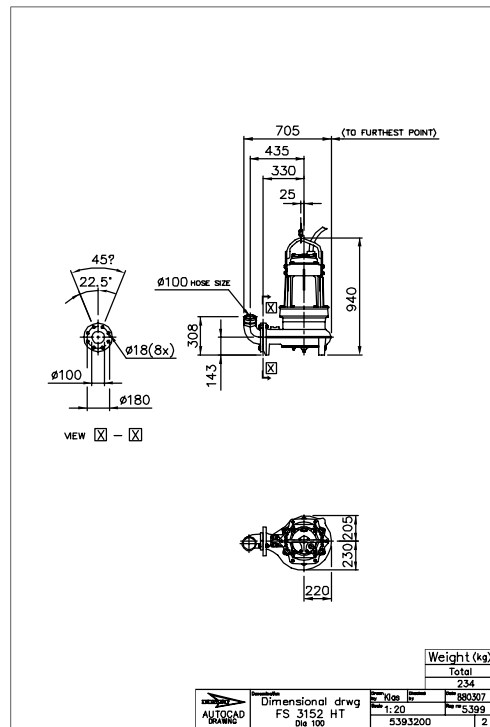

Xylem |'zīləm|

- 1) The tissue in plants that brings water upward from the roots
- 2) A leading global water technology company

We're 12,000 people unified in a common purpose: creating innovative solutions to meet our world's water needs. Developing new technologies that will improve the way water is used, conserved, and re-used in the future is central to our work. We move, treat, analyze, and return water to the environment, and we help people use water efficiently, in their homes, buildings, factories and farms. In more than 150 countries, we have strong, long-standing relationships with customers who know us for our powerful combination of leading product brands and applications expertise, backed by a legacy of innovation.

For more information on how Xylem can help you, go to xylem.com



Xylem Water Solutions AB
Gesällvägen 33
174 87 Sundbyberg
Sweden
Tel. +46-8-475 60 00
Fax +46-8-475 69 00
<http://tpi.xylem.com>

Visit our Web site for the latest version of this document and more information

The original instruction is in English. All non-English instructions are translations of the original instruction.

© 2011 Xylem Inc