

F 3152

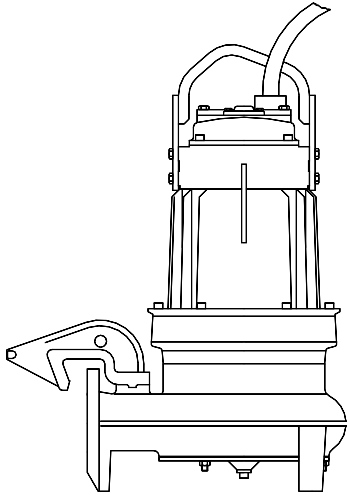

FP/FS/FJ

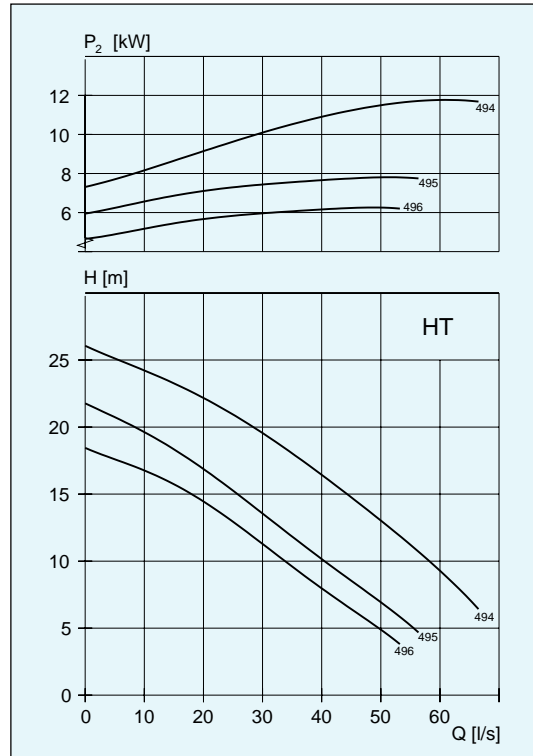

Pump type	FP	FS	FJ
Weight, kg	235	234	241

Impeller code	No. of vanes	Outlet dia mm FP vers.	Motor rating kW		rpm	Available versions
			P ₁	P ₂		
494	2	100	15.8	13.5	1450	FP/FS/FJ
495	2	100	15.8	13.5	1450	FP/FS/FJ
495	2	100	10.7	9.0	1450	FP/FS/FJ
496	2	100	15.8	13.5	1450	FP/FS/FJ
496	2	100	10.7	9.0	1450	FP/FS/FJ
496	2	100	8.9	7.5	1450	FP/FS/FJ

FP/FS/FJ

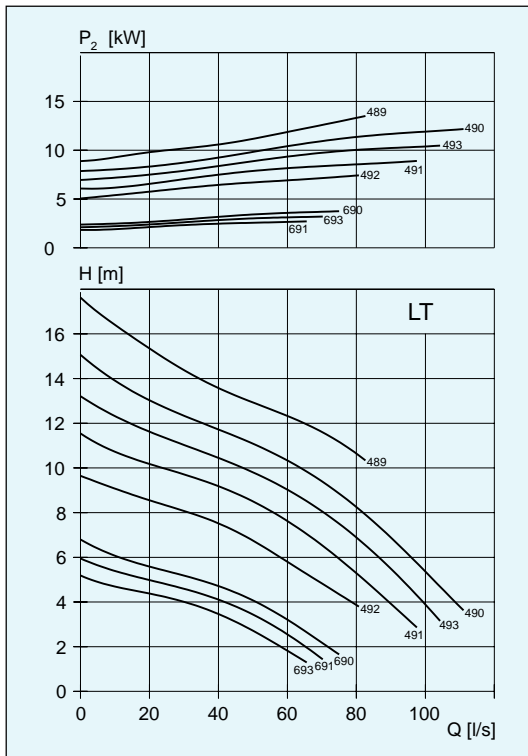

Impeller code	No. of vanes	Outlet dia mm FP vers.	Motor rating kW		rpm	Available versions
			P ₁	P ₂		
489	2	150	15.8	13.5	1450	FP/FS/FJ
490	2	150	15.8	13.5	1450	FP/FS/FJ
491	2	150	15.8	13.5	1450	FP/FS/FJ
491	2	150	10.7	9.0	1450	FP/FS/FJ
492	2	150	10.7	9.0	1450	FP/FS/FJ
492	2	150	8.9	7.5	1450	FP/FS/FJ
493	2	150	15.8	13.5	1450	FP/FS/FJ
690	2	150	10.5	8.8	900	FP/FS/FJ
691	2	150	10.5	8.8	900	FP/FS/FJ
693	2	150	10.5	8.8	900	FP/FS/FJ