



Technical specification

Solids handling pump DS/DP 2720, 50 Hz



Flygt



ITT Industries



DS/DP 2720

Product

Submersible pump for pumping chemically contaminated liquids and suspensions. The pump is designed for use in corrosive industrial waste water and can handle water containing relatively abrasive solids.

Denomination

Product code	2720.280
Installation	S, P
Impeller characteristics	MT

Process data

Liquid temperature	max +40°C
Depth of immersion	max 20 m
Liquid density	max 1100 kg/m ³
The pH of the pumped liquid	pH 2 - 10

Motor data

Frequency	50 Hz
Insulation class	F (+155°C)
Voltage variation	
- continuously running	max ± 5%
- intermittent running	max ± 10%
Voltage imbalance between phases	max 2%
No. of starts/hour	max 15

Cable

SUBCAB®	4G 1.5+2x1.5
	4G 2.5+2x1.5

Monitoring equipment

Thermal contacts opening temp.	+130°C
--------------------------------	--------

Material

Impeller	Stainless steel
Wear parts	Stainless steel
Stator housing	Stainless steel
Strainer	Stainless steel
Shaft	Stainless steel
Stationary wear ring	Stainless steel
O-rings	Fluorinated rubber

Mechanical face seals

Alternative	Inner seal	Outer seal
1	Carbon/Silicon carbide	Silicon carbide/Silicon carbide

Surface Treatment

No surface treatment

Weight

See dimensional drawing

Option

Starters

Accessories

Adapters, hose connections and other mechanical accessories.

Electrical accessories such as pump controller, control panels, monitoring relays, cables.

See separate booklet or www.flygt.com, for further information.

MT- Motor rating and performance curve

2720.280

Curve/Impeller No	Rated Power, kW (hp)	Rated current, A	Starting current, A	Power factor cos ϕ	Ex proof version available
220 V D, 50 Hz, 3~, 2680 r/min					
241	2.0	7.8	36	0.87	No
230 V D, 50 Hz, 3~, 2715 r/min					
241	2.0	7.7	39	0.84	No
380 V Y, 50 Hz, 3~, 2680 r/min					
241	2.0	4.5	21	0.87	No
400 V Y, 50 Hz, 3~, 2610 r/min					
241	2.0	4.3	17	0.90	No
500 V Y, 50 Hz, 3~, 2620 r/min					
241	2.0	3.4	14	0.90	No
550 V Y, 50 Hz, 3~, 2700 r/min					
241	2.0	3.2	16	0.86	No

Y/D starting current is approximately 1/3 of D starting current.

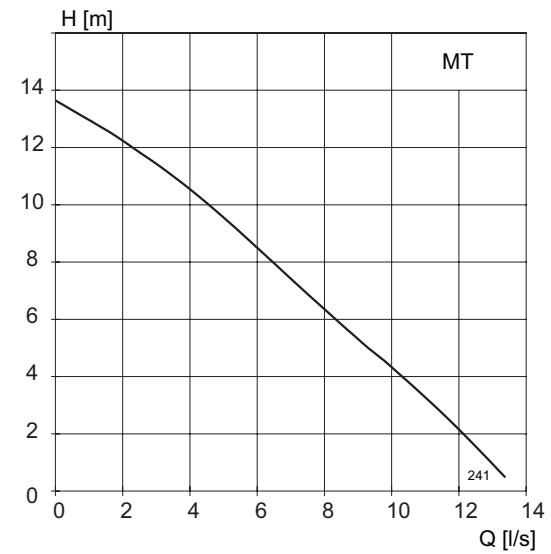
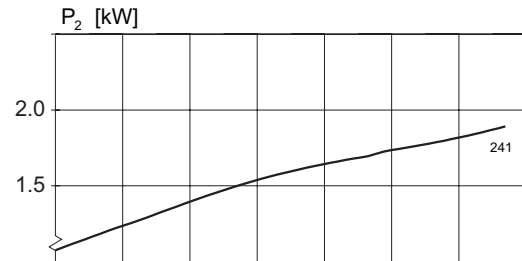

Dimensional drawing

All drawings are available as Acrobat documents (.pdf) and AutoCad drawings (.dwg). Download the drawings from www.flygt.com or contact your ITT Flygt representative for more information.

All dimensions are in mm.

MT, S-installation

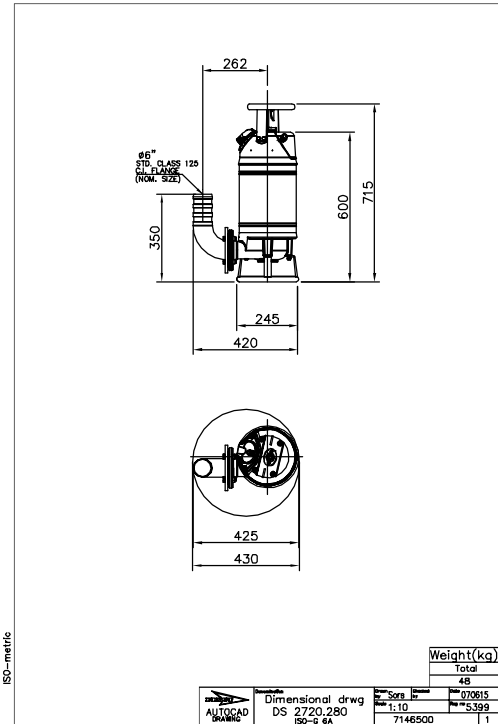

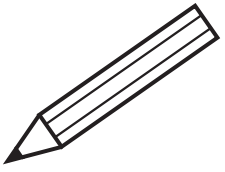

A series of horizontal dashed lines for writing, starting below the pencil illustration and extending to the bottom of the page.



www.flygt.com