



Flygt D 8000

Corrosion-resistant submersible
vortex pumps



Engineered for life

Wide open to the challenge of corrosive media

Handling corrosive wastewater containing a substantial amount of solids and/or fibrous matter poses distinct challenges. For times like these, there's the Flygt D 8000, a stainless steel submersible vortex pump. Designed to tackle tough fluid handling challenges, the Flygt D 8000 does the jobs that no other pump can do – reliably and cost-efficiently.

The Flygt D 8000 is a highly reliable submersible vortex pump that cost-effectively transports corrosive media. Completely made of stainless steel, the Flygt D 8000 features a vortex impeller and wide throughlet that ensure consistent performance over time, trouble-free operation and minimal maintenance.

Engineered for demanding and potentially explosive environments, the Flygt D 8000 easily transports corrosive media for municipal sewage and industrial wastewater applications just as easily as it does for a wide range of applications in the chemical, food processing, pharmaceutical, textile and tunneling industries.

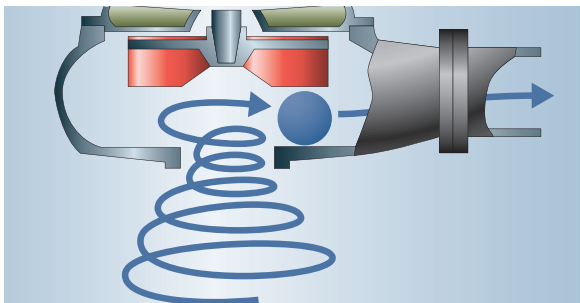

High operational reliability, low wear: The powerful pumping action of the vortex impeller enables easy passage of larger solids through a wide, unobstructed channel.

Straightforward non-clogging vortex design

The high quality and unmatched performance of the Flygt D 8000 should come as no surprise. After all, ITT is the world-leading manufacturer and supplier of submersible pumps. Here are some of the design finesses that make the Flygt D 8000 the submersible vortex pump of choice.

Advantages

- **Reliable, cost-efficient performance.** Non-clogging vortex design delivers highly reliable, cost-effective performance.
- **Excellent corrosion-resistance.** Pump materials easily handle highly acidic or alkaline liquids with pH values between 2 and 14.
- **Reduced wear.** Minimal direct contact of the impeller vanes with solids greatly reduces wear.
- **Very low maintenance requirements.** The wide throughlet and reduced radial forces on the impeller enables operation at very low flows or shut off for extended periods without damage.
- Slim pump design for installation into smaller sumps, where required.
- Thermal sensors embedded in the stator windings to prevent overheating.



Precision casting improves performance and reduces weight.

Options

- AISI 329 duplex stainless steel for enhanced resistance against corrosion and abrasion
- Cable protection with stainless steel hose
- Explosion-proof version (ATEX-compliant)
- Leakage sensors in the stator and oil housings



Reliable design for high performance

International standards approvals.
All pumps are tested and approved in accordance with national and international standards (IEC 34-1 CSA).

Two sets of mechanical shaft seals.
Work independently to provide double security.

Back impeller vanes. Prevent solids from entering the seal area and reduce pressure on the seal.

Wide throatlet. Enables the free passage of larger solids and abrasive particles up to 100 mm in diameter.

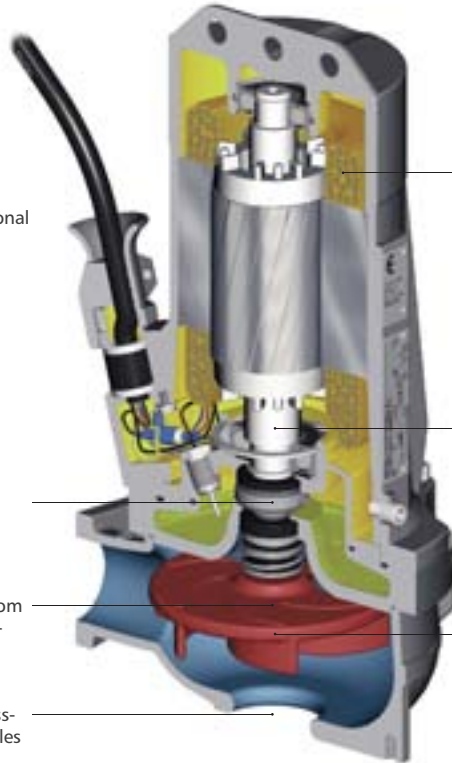

High-performance squirrel-cage induction motor. Provides reliable operation. Class F insulated, specially designed and manufactured by ITT for submersible use.

Shaft. A short overhang virtually eliminates shaft deflection. Reduces noise levels and vibration while significantly increasing seal and bearing life.

Semi-recessed vortex impeller. Creates pumping action by transferring energy to the pumped fluid, which in turn produces a secondary swirling vortex flow.

Model	D 8050	D 8053	D 8056	D 8058
Rating 50Hz	1.5–2.6 kW	3.5–4 kW	5–7.5 kW	9–13 kW
Discharge (DN)	50 mm	50 mm	-	-
	65 mm	65 mm	65 mm	65 mm
	100 mm	100 mm	100 mm	100 mm
Pressure characteristic	LT, MT, HT	LT, MT, HT	LT, MT, HT	LT, HT

Performance (50 Hz)

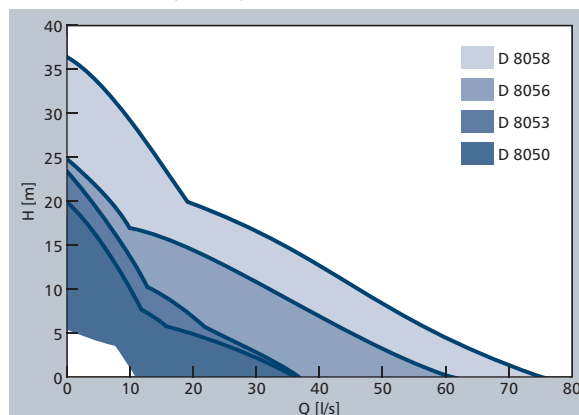

Installation

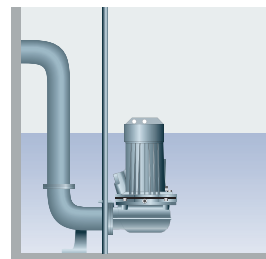

Totally secure: For stationary or semi-permanent fixed installation.

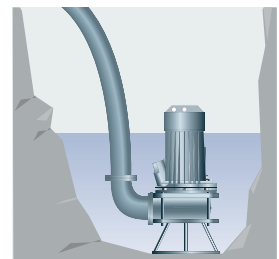

Completely transportable: For temporary installation with stand and hose connection.



What can ITT Water & Wastewater do for you?

ITT Water & Wastewater is a global provider of water handling and treatment solutions for municipal and industrial customers in more than 140 countries. ITT designs and delivers energy-efficient solutions and related services for water and wastewater transport, biological treatment, filtration and disinfection. The company employs nearly 5,000 people through its global sales network, manufacturing sites in Europe, Asia and the Americas, and global headquarters in Stockholm, Sweden. ITT Water & Wastewater is a business of ITT Corporation, a high-technology engineering and manufacturing company operating in three vital markets: water and fluids management, global defence and security, and motion and flow control.

www.ittwww.com

