

NS 3171 (Continued)

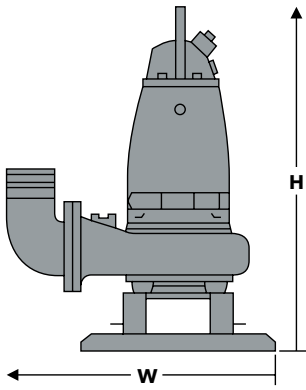

Model number: 3171.185
 Motor rating: 30 HP@1740 RPM
 34 HP@3525 RPM
 Voltage (3 ϕ): 230V 460V
 Full load amps: 74/79A 37/40A
 575V
 25/30/31A
 Versions: 4" Super high head
 Imp. Code 275
 4" High head
 Imp. Code 454
 Hose connection: 4", 6" & 10" Slip-on
 Pump dimensions: 45¹/₂" W (max.) x 51¹/₄" H (max.)
 Max. weight (lbs.): 1060 - High volume, 770 - Standard
 Description: Cast iron construction; semi-open,
 backswept multi-vane, self-cleaning
 impeller; rests on stand.
 Options: Explosion proof (FM approved)
 variant 3171.095

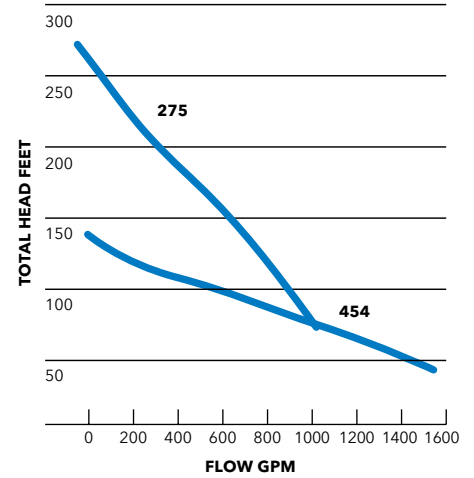

NS 3202

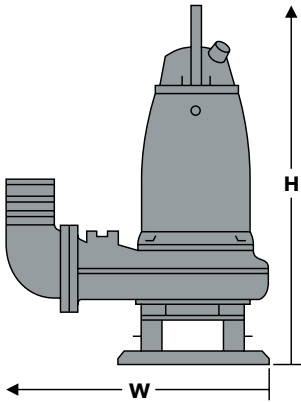

Model number: 3202.185
 Motor rating: 60 HP@1170 RPM & 1775 RPM
 70 HP@1775 RPM
 Voltage (3 ϕ): 460V 575V
 Full load amps: 72/68/80A 58/55/63A
 Versions: 6" High head
 Imp. Code 458
 8" Standard
 Imp. Code 640
 10" High volume
 Imp. Code 614
 Hose connection: 6", 8" & 10" Slip-on
 Pump dimensions: 52¹/₂" W (max.) x 62" H (max.)
 Max. weight (lbs.): 1985 - High volume
 1340 - Standard
 Description: Cast iron construction; semi-open,
 backswept multi-vane, self-cleaning
 impeller; rests on stand.
 Options: Explosion proof (FM approved)
 variant 3202.095

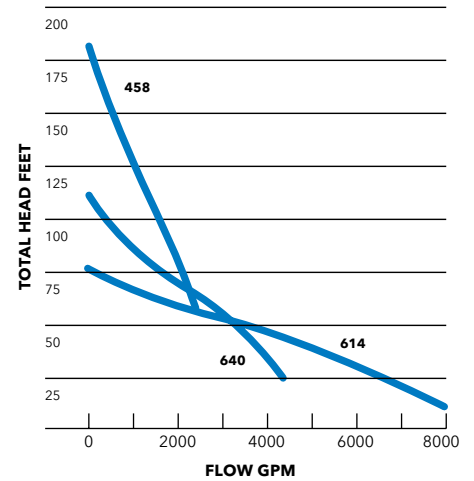

NS 3301

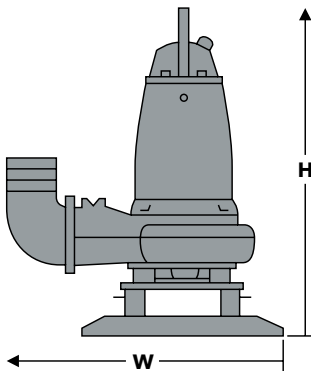

Model number: 3301.185
 Motor rating: 85 HP@1185 RPM
 105 HP@1780 RPM
 Voltage (3 ϕ): 460V 575V
 Full load amps: 109/121A 88/97A
 Versions: 6" High head
 Imp. Code 462
 10" Standard
 Imp. Code 636
 12" High volume
 Imp. Code 624
 Hose connection: 6", 10" & 12" Slip-on
 Pump dimensions: 56³/₄" W (max.) x 67¹/₄" H (max.)
 Max. weight (lbs.): 1985 - High volume
 1340 - Standard
 Description: Cast iron construction; semi-open,
 backswept multi-vane, self-cleaning
 impeller; rests on stand.
 Options: Explosion proof (FM approved)
 variant 3301.095

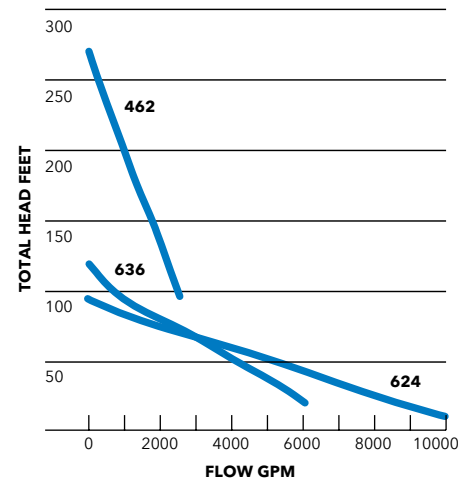

3000 Series Heavy-Duty Sewage Pumps for Rental

When higher capacity is required, these models deliver unprecedented pumping power - reliably and efficiently.

NS 3315

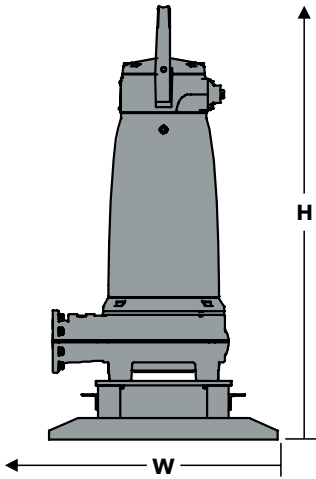

Model number: 3315.090
 Motor Rating: 160HP @ 1780 RPM

Voltage: 460V
 Full load amps: 190
 Versions: 6" High Head
 Imp. Code 458

Hose connection: NPSM threaded
 Pump dimensions: 40 1/8" W x 78 1/2" H
 Max. weight (lbs.): 2690
 Description: Cast iron construction;
 semi-open, backswept
 multi-vane, self-cleaning
 impeller; rests on bottom stand.

Options: Explosion proof (FM approved)

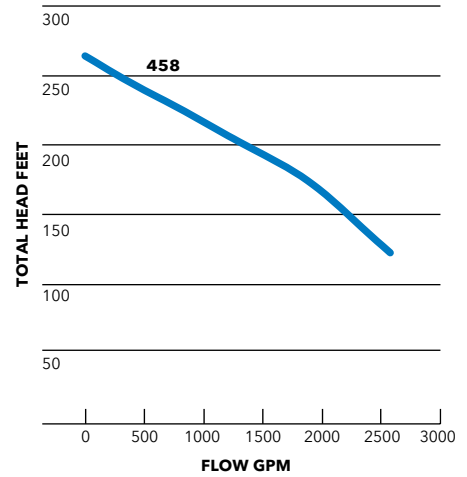

NS 3312

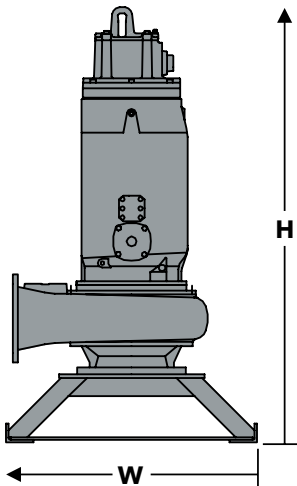

Model number: 3312/746
 Motor Rating: 215HP @ 1185 RPM

Voltage: 460V
 Full load amps: 254
 Versions: 12" Standard
 Imp. Code 670 (455mm trim)

Hose connection: ANSI Flange
 Pump dimensions: 52 5/8" W x 93 3/4" H
 Max. weight (lbs.): 5126
 Description: Cast iron construction;
 semi-open, backswept
 multi-vane, self-cleaning
 impeller; rests on bottom stand.

