



Flygt Submersible Pumps

AVAILABLE FOR RENTAL AND SALE



www.motralec.com / service-commercial@motralec.com / 01.39.97.65.10

Stainless Steel 3000 Series Sludge and Solids-Handling Sewage Pumps

CS/DS 3060 (SS)

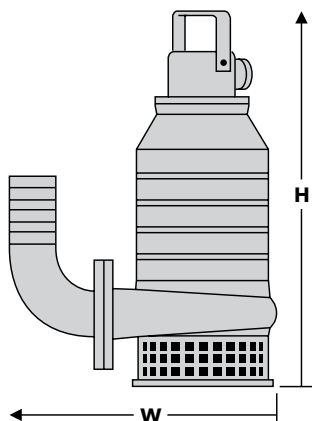

Model number: 3060.390
 Motor rating: 1ø: 2.5 HP @ 3400 RPM
 3ø: 3.7 HP @ 3300 RPM

Voltage (1ø): 230V
 Full load amps: 11A

Voltage (3ø): 200V 230V 460V 575V
 Full load amps: 10.8A 9.4A 4.7A 3.8A

Versions: CS: 3" Standard
 Imp. Code 226 (1ø), 222 (3ø)
 DS: 3" Vortex
 Imp. Code 276 (1ø), 274 (3ø)

Hose connection: Slip-on
 Pump dimensions: 16 1/2" W (max.) x 23 1/2" H (max.)
 Max. weight (lbs.): 95

Description: CS/DS: Stainless steel construction; rests on bottom strainer. CS: Open impeller, with diffuser. DS: Vortex type impeller.

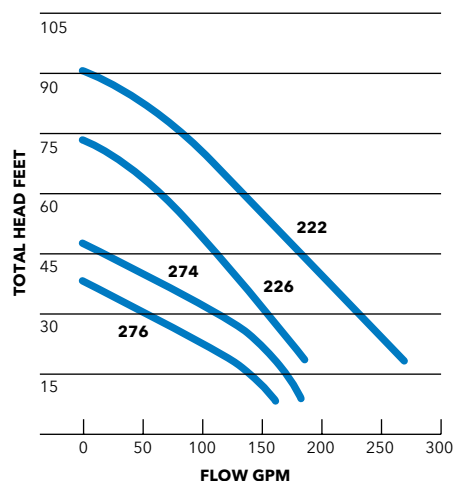

CS 3201 (SS)

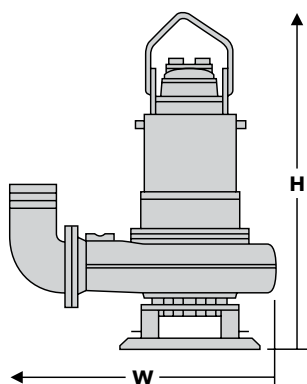

Model number: 3201.280
 Motor rating: 30 HP @ 860 RPM
 35 HP @ 1170 RPM
 47 HP @ 1760 RPM

Voltage (3ø): 230V
 Full load amps: 82/94/116A

Voltage (3ø): 460V 575V
 Full load amps: 41/47/58A 33/38/46A

Versions: 6" High hd., Imp. Code 452 (47 HP)
 8" Std., Imp. Code 636 (35 HP)
 10" High volume
 Imp. Code 821 (30 HP)

Hose connection: Slip-on
 Pump dimensions: 56" W (max.) x 63" H (max.)
 Max. weight (lbs.): 1600

Description: Stainless steel construction; closed, solids handling impeller, wear rings; rests on bottom stand.

Options: Explosion proof (FM approved) variant 3201.290

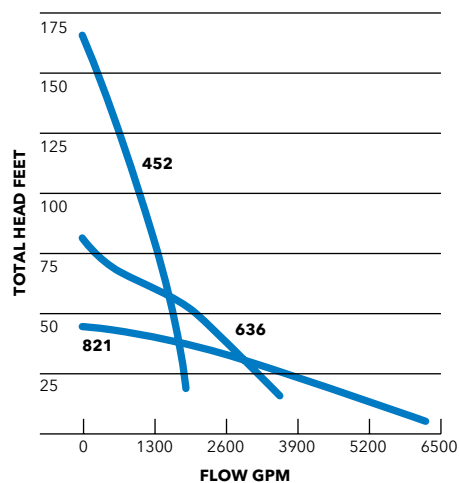

CS 3300 (SS)

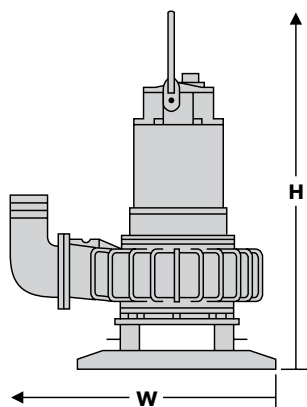

Model number: 3300.280
 Motor rating: 60 HP @ 1170 RPM & 875 RPM
 45 HP @ 875 RPM
 77, 88 HP @ 1170 RPM

Voltage (3ø, 60 HP): 460V 575V
 Full load amps: 73/80A 58/65A

Voltage (3ø, 45/77/88 HP): 460V 575V
 Full load amps: 60/91/108A 48/73/86A

Versions: 6" High hd., Imp. Code 464 (88 HP)
 8" Standard
 Imp. Code 646 (60 HP), 642 (77 HP)
 10" High volume
 Imp. Code 807 (45 HP), 804 (60 HP)

Hose connection: Slip-on
 Pump dimensions: 56 3/4" W (max.) x 75 3/4" H (max.)
 Max. weight (lbs.): 2590

Description: Stainless steel construction; closed, solids handling impeller, wear rings; rests on bottom stand.

