



# Flygt Submersible Pumps

AVAILABLE FOR RENTAL AND SALE



[www.motralec.com](http://www.motralec.com) / [service-commercial@motralec.com](mailto:service-commercial@motralec.com) / 01.39.97.65.10

## CS 3127

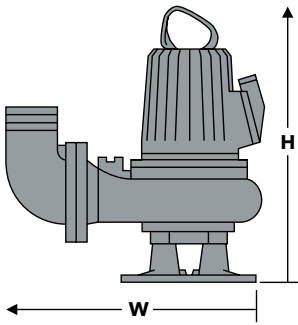

Model number: 3127.182  
 Motor rating: 1 $\phi$ : 7.5HP@1730 RPM  
 3 $\phi$ : 10HP@1730 RPM  
 Voltage (1 $\phi$ ): 230V  
 Full load amps: 30A  
 Voltage (3 $\phi$ ): 200V 230V 460V 575V  
 Full load amps: 29A 26A 13A 10A  
 Versions: 4" High head  
 Imp. Code 462 (1 $\phi$ ), 483 (3 $\phi$ )  
 6" Std., Imp. Code 433 (1 $\phi$ ), 432 (3 $\phi$ )  
 8" Std., Imp. Code 412 (1 $\phi$ ), 411 (3 $\phi$ )  
 Hose connection: 4" & 6" NPSM threaded, or  
 4", 6" & 8" slip-on  
 Pump dimensions: 31 1/2" W (max.) x 30 3/4" H (max.)  
 Max. weight (lbs.): 400  
 Description: Cast iron construction; closed  
 solids handling impeller with  
 thrulet, wear ring; rests on stand.  
 Options: Explosion proof (FM approved)  
 variant 3127.091  
 Warm liquid version available

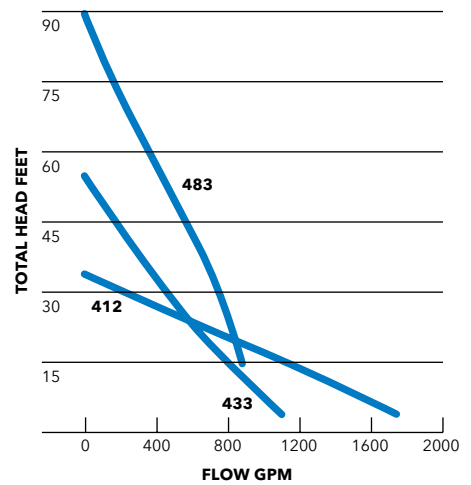

## CS3152

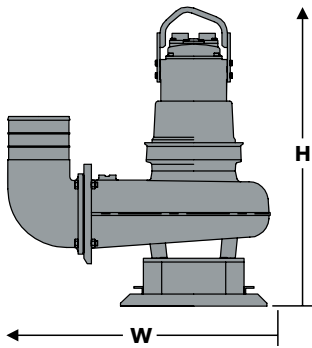

Model number: 3152.181  
 Motor rating: 14HP @ 1160 RPM  
 15HP @ 1745 RPM  
 20HP @ 1750 RPM  
 23HP @ 3500 RPM  
 Voltage (3 $\phi$ , 14 / 15HP): 200V 230V 460V 575V  
 Full load amps: 41/45 37/39 18/20 14/16  
 Voltage (3 $\phi$ , 20 / 23HP): 200V 230V 460V 575V  
 Full load amps: 58/61 51/53 26/26 20/21  
 Versions: 4" High head  
 Imp. Code 454 (20HP), 268 (SH, 23HP)  
 6" Standard, Imp. Code 436 (15HP)  
 10" High Volume, Imp. Code 620 (14HP)  
 Hose connection: 4" & 6" NPSM threaded, or  
 4", 6" & 8" slip-on  
 Pump dimensions: 42" W (max.) x 48-1/4" H (max.)  
 Max. weight (lbs.): 940  
 Description: Cast iron construction; closed  
 solids handling impeller with  
 thrulet, wear ring; rests on stand.  
 Options: Explosion proof (FM approved)  
 variant 3127.091  
 Warm liquid version available

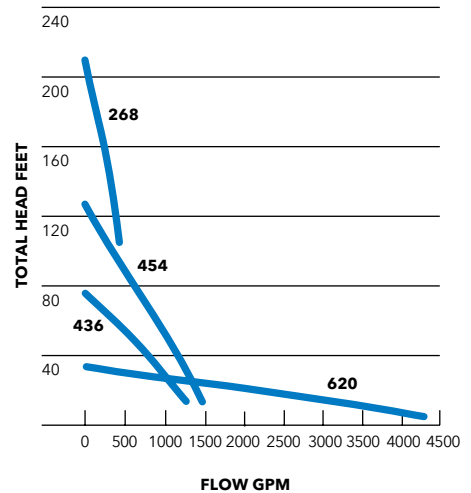

## CS 3300

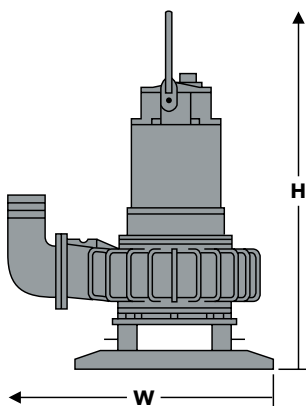

Model number: 3300.181  
 Motor rating: 60HP@1170 RPM & 875 RPM  
 45 HP@875 RPM  
 75 HP, 88 HP@1170 RPM  
 Voltage (3 $\phi$ , 60HP): 460V 575V  
 Full load amps: 73/80A 58/65A  
 Voltage (3 $\phi$ , 45/75/88 HP): 460V 575V  
 Full load amps: 60/91/108A 48/73/86A  
 Versions: 6" High head, Imp. Code 464 (88 HP)  
 8" Standard  
 Imp. Code 646 (60HP), 642 (75 HP)  
 10" High volume  
 Imp. Code 807 (45HP), 804 (60HP)  
 Hose connection: Slip-on  
 Pump dimensions: 66" W (max.) x 75 3/4" H (max.)  
 Max. weight (lbs.): 1915  
 Description: Cast iron construction; closed  
 solids handling impeller with  
 thrulet, wear ring; rests on stand.  
 Options: Explosion proof (FM approved)  
 variant 3300.091

