

C-PUMPS • 50 Hz IN STAINLESS STEEL

C 3060

Stainless steel

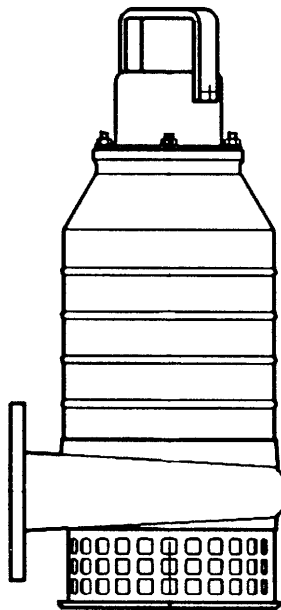

	CP	CT	CS
Weight, kg (with cooling jacket)	41	45	41
	41	45	41

CP/CT/CS

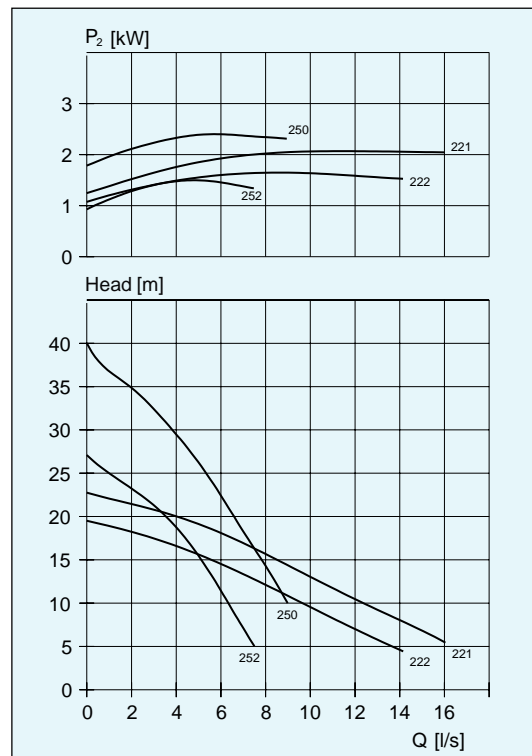

Impeller code	No. of vanes	Outlet dia mm CP vers.	Through-let, mm	Motor rating kW		rpm	Available versions
				P ₁	P ₂		
221	2	80	15 x 15	3.3	2.4	2800	CP/CT/CS
222	2	80	15 x 15	3.3	2.4	2800	CP/CT/CS
250	2	80	15 x 15	3.3	2.4	2800	CP/CS
252	2	80	15 x 15	3.3	2.4	2800	CP/CS

C 3085

Stainless steel

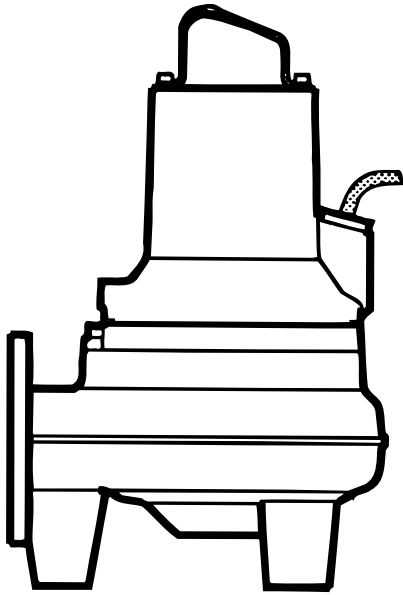

Weight, kg	CP	CS
MT	72	72

*NEVACLOG

CP/CS

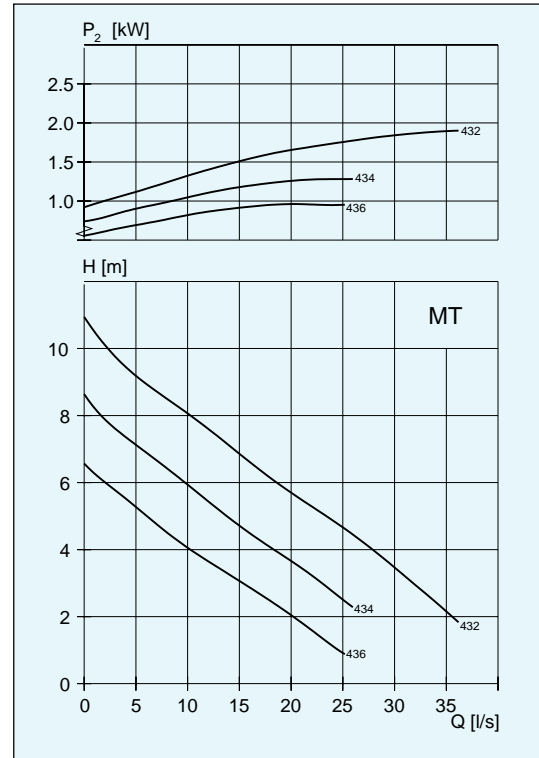

Impeller code	No. of channels	Outlet dia mm CP vers.	Through-let, mm	Motor rating kW		rpm	Available versions
				P_1	P_2		
432*	1	80	∅ 73	27	20	1385	CP/CS
434*	1	80	∅ 73	27	20	1385	CP/CS
436*	1	80	∅ 73	27	20	1385	CP/CS

C 3126

Stainless steel

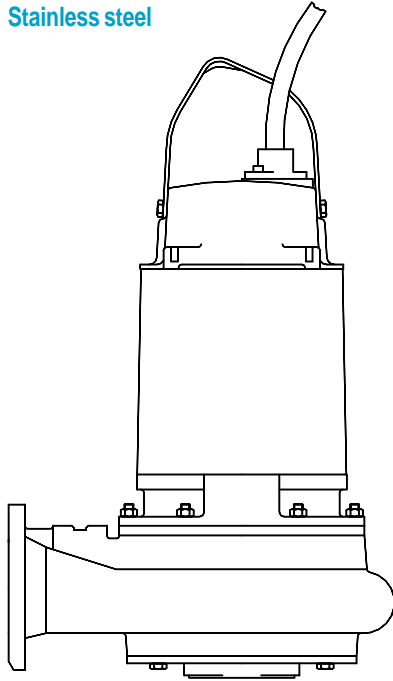

Weight, kg	CP	CS	CT	CZ
HT	156	162	185	255
MT	164	168	215	263

CP/CS/CT/CZ

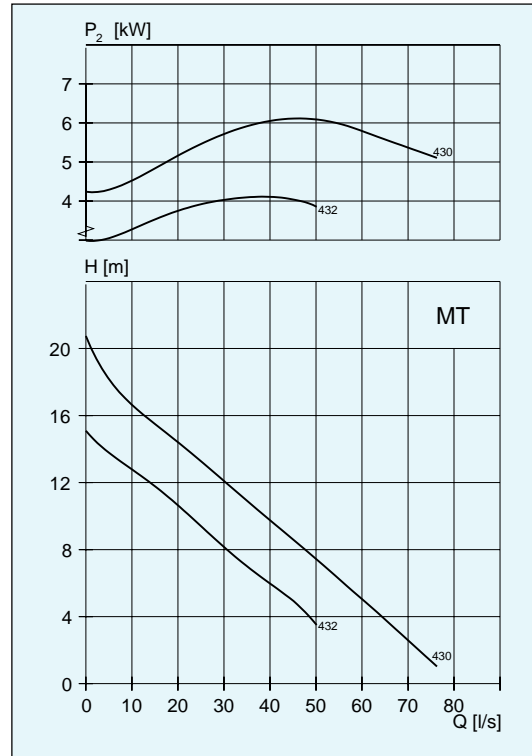

Impeller code	No. of channels	Outlet dia mm CP vers.	Through-let, mm	Motor rating kW		rpm	Available versions
				P ₁	P ₂		
W430	1	100	100x110	8.0	6.7	1440	CP/CS/CT/CZ
W432	1	100	87x100	8.0	6.7	1440	CP/CS/CT/CZ
W432	1	100	87x100	6.5	5.3	1435	CP/CS/CT/CZ

CP/CS/CT/CZ

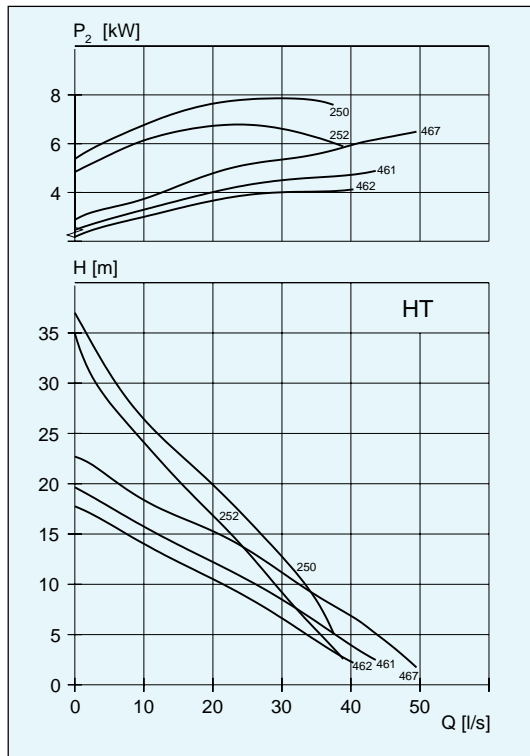

Impeller code	No. of channels	Outlet dia mm CP vers.	Through-let, mm	Motor rating kW		rpm	Available versions
				P ₁	P ₂		
W250	1	80	∅ 58	9.5	8.0	2890	CP/CS/CT/CZ
W252	1	80	∅ 58	9.5	8.0	2890	CP/CS/CT/CZ
W461	1	100	∅ 76	8.0	6.7	1440	CP/CS/CT/CZ
W461	1	100	∅ 76	6.5	5.3	1435	CP/CS/CT/CZ
W462	1	100	∅ 76	8.0	6.7	1440	CP/CS/CT/CZ
W462	1	100	∅ 76	6.5	5.3	1435	CP/CS/CT/CZ
W467	1	100	∅ 76	8.0	6.7	1440	CP/CS/CT/CZ

C 3201

Stainless steel

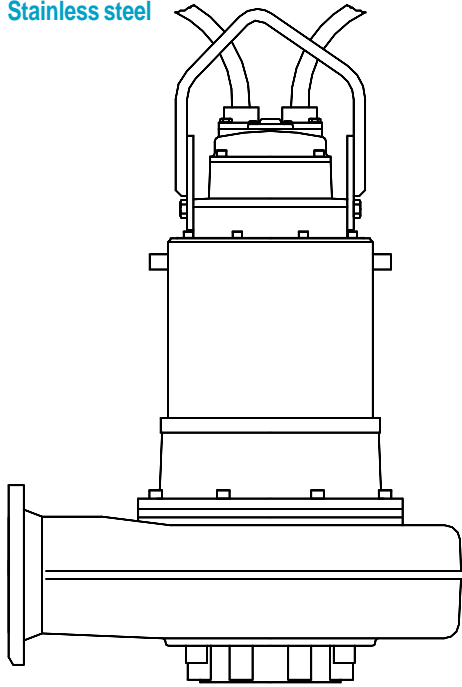

Weight, kg	CP	CS	CT	CZ
HT	560	510	675	675
MT	550	500	580	580

CP/CS/CT/CZ

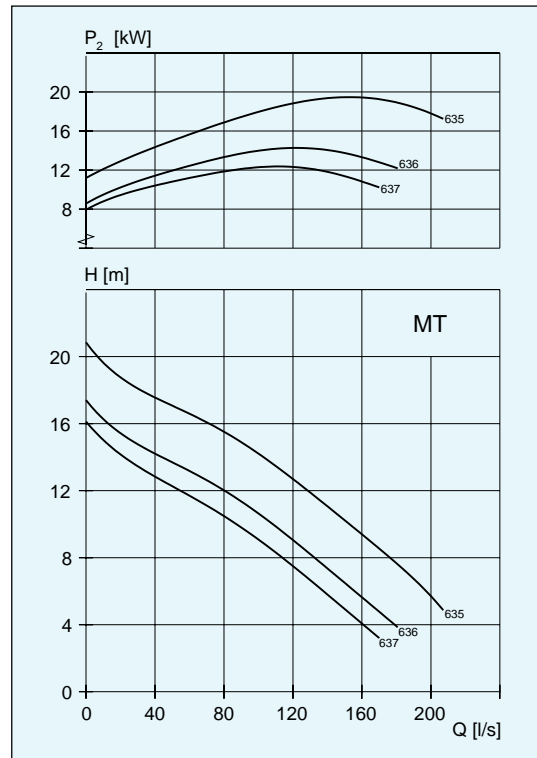

Impeller code	No. of channels	Outlet dia mm CP vers.	Through-let, mm	Motor rating kW		rpm	Available versions
				P ₁	P ₂		
W635	2	250	102 x 84	25	22	970	CP/CS/CT/CZ
W636	2	250	102 x 84	25	22	970	CP/CS/CT/CZ
W637	2	250	102 x 84	25	22	970	CP/CS/CT/CZ

CP/CS/CT/CZ

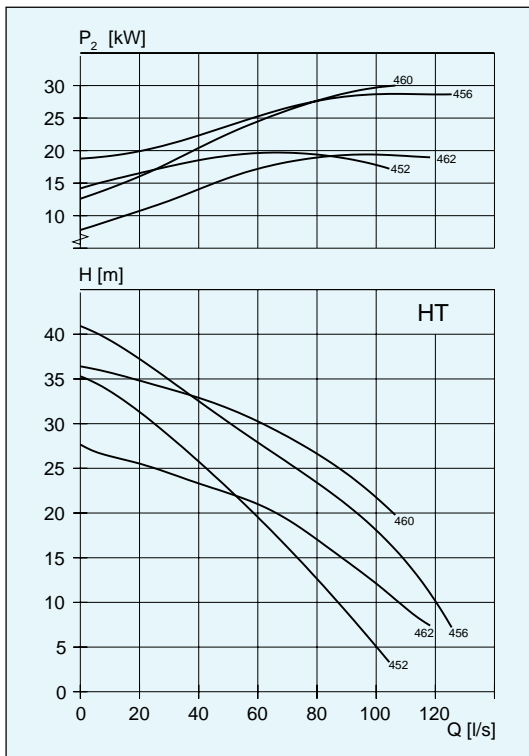

Impeller code	No. of channels	Outlet dia mm CP vers.	Through-let, mm	Motor rating kW		rpm	Available versions
				P ₁	P ₂		
W452	1	200	77 x 77	34	30	1455	CP/CS/CT/CZ
452	1	200	77 x 77	25	22	1460	CP/CS/CT/CZ
456	1	200	∅ 100	34	30	1455	CP/CS/CT/CZ
460	3	200	59 x 65	34	30	1455	CP/CS/CT/CZ
W462	3	200	59 x 65	34	30	1455	CP/CS/CT/CZ
462	3	200	59 x 65	25	22	1460	CP/CS/CT/CZ

C 3300

Stainless steel

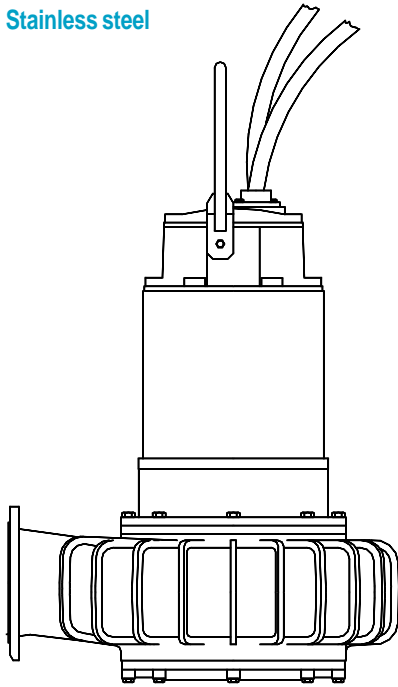

Weight, kg	CP	CS	CT	CZ
HT	950	1003	1043	1043
MT	1150	1176	1236	1236

CP/CS/CT/CZ

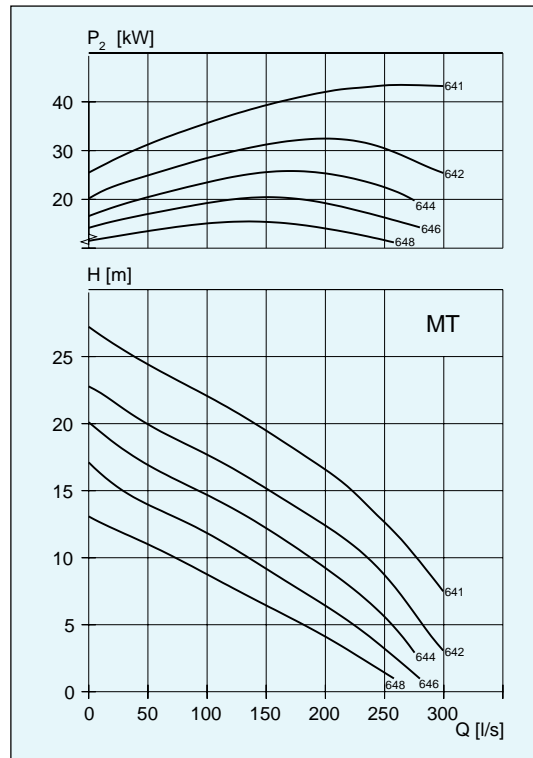

Impeller code	No. of channels	Outlet dia mm CP vers.	Through-let, mm	Motor rating kW		rpm	Available versions
				P ₁	P ₂		
641	2	300	100x100	50	44	975	CP/CS/CT/CZ
642	2	300	100x100	50	44	975	CP/CS/CT/CZ
644	2	300	100x100	50	44	975	CP/CS/CT/CZ
646	2	300	100x100	50	44	975	CP/CS/CT/CZ
648	2	300	100x100	50	44	975	CP/CS/CT/CZ

CP/CS/CT/CZ

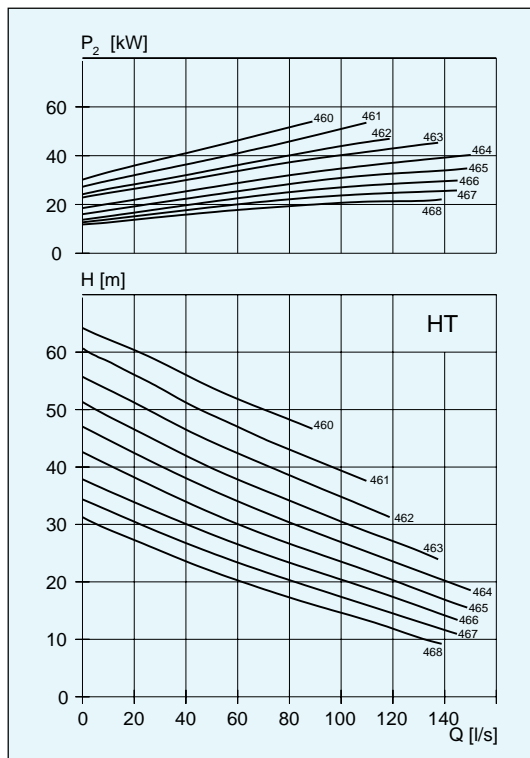

Impeller code	No. of channels	Outlet dia mm CP vers.	Through-let, mm	Motor rating kW		rpm	Available versions
				P ₁	P ₂		
460	2	200	76 x 76	59	54	1475	CP/CS/CT/CZ
460	2	200	76 x 76	45	40	1475	CP/CS/CT/CZ
461	2	200	76 x 76	59	54	1475	CP/CS/CT/CZ
462	2	200	76 x 76	59	54	1475	CP/CS/CT/CZ
463	2	200	76 x 76	59	54	1475	CP/CS/CT/CZ
464	2	200	76 x 76	59	54	1475	CP/CS/CT/CZ
465	2	200	76 x 76	59	54	1475	CP/CS/CT/CZ
466	2	200	76 x 76	59	54	1475	CP/CS/CT/CZ
466	2	200	76 x 76	45	40	1475	CP/CS/CT/CZ
467	2	200	76 x 76	59	54	1475	CP/CS/CT/CZ
467	2	200	76 x 76	45	40	1475	CP/CS/CT/CZ
468	2	200	76 x 76	59	54	1475	CP/CS/CT/CZ