

C-PUMPS • 50 Hz

SMALL AND MEDIUM SIZE

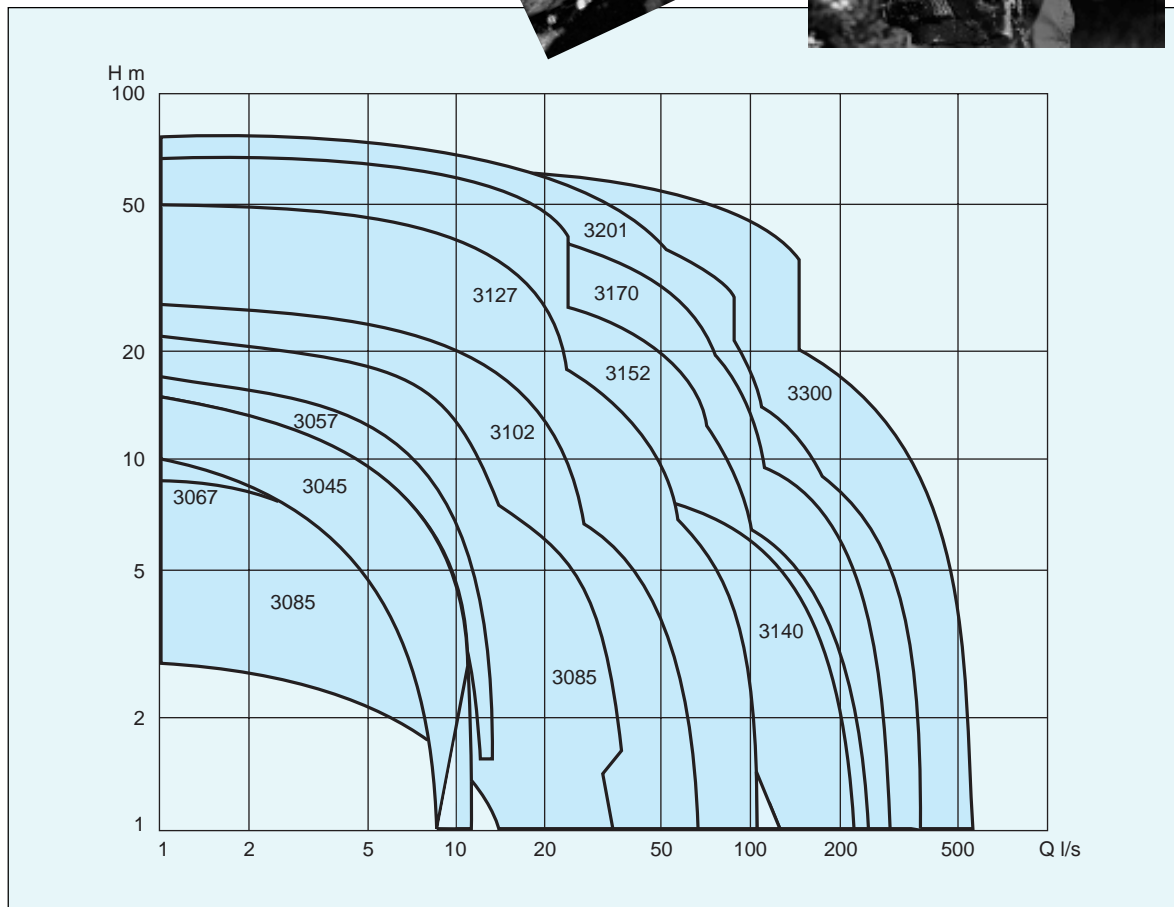

The conventional single-channel impeller is a shrouded channel impeller running in a volute. The shape and size of the channel minimize clogging, and therefore makes the pump ideal for waste water, containing large solid particles. See also chapter N-pumps.



C 3045

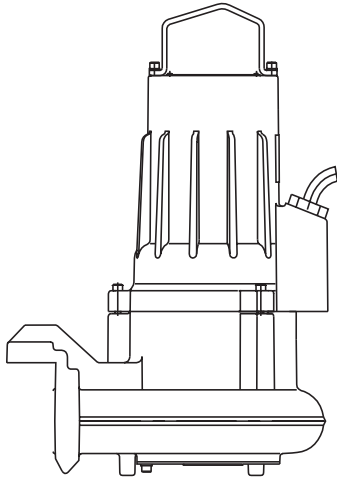

Pump type	CP	CF	CH	CS
Weight kg	28	28	28	28

CP/CF/CH/CS

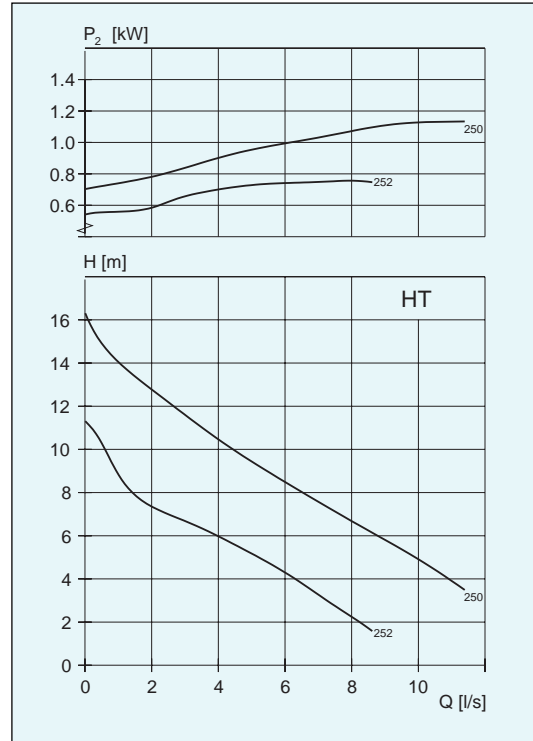

Impeller code	No. of vanes	Outlet dia mm CP vers.	Through-let, mm	Motor rating kW P_1 P_2	rpm	Available versions
250	1	50	46	1.5 1.2	2790	CP/CF/CH/CS
252	1	50	46	1.5 1.2	2790	CP/CF/CH/CS
252	1	50	46	1.0 0.8	2870	CP/CF/CH/CS

CP/CF/CH/CS

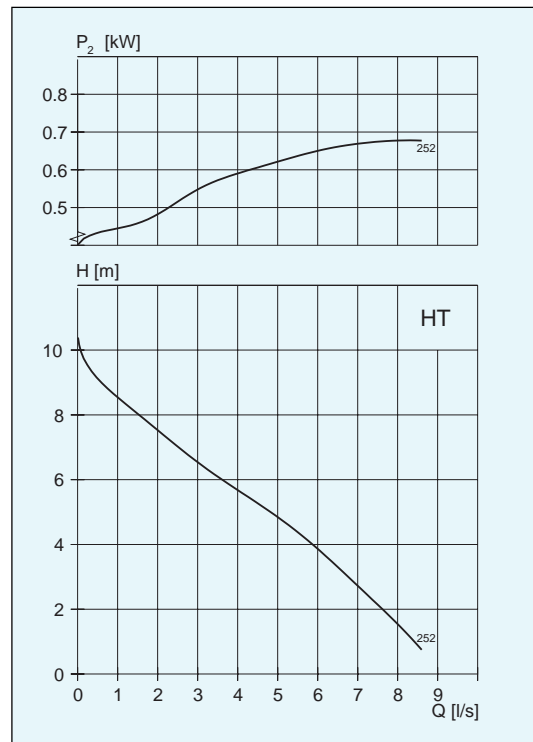

Impeller code	No. of vanes	Outlet dia mm CP vers.	Through-let, mm	Motor rating kW P_1 P_2	rpm	Available versions
252*	1	50	46	1.0 0.75	2740	CP/CF/CH/CS

* Single phase

C 3057

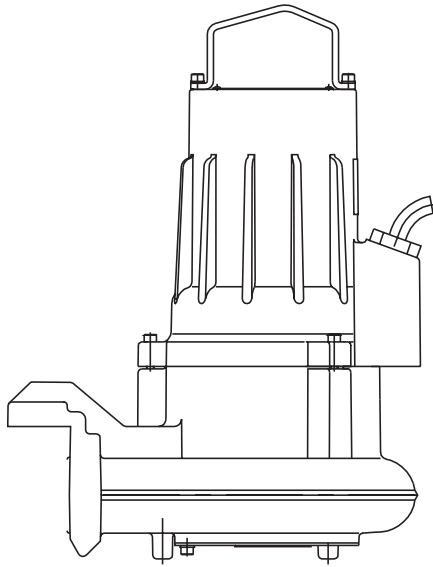

Weight kg	CP	CF	CS
HT	34	34	34

CP/CF/CS

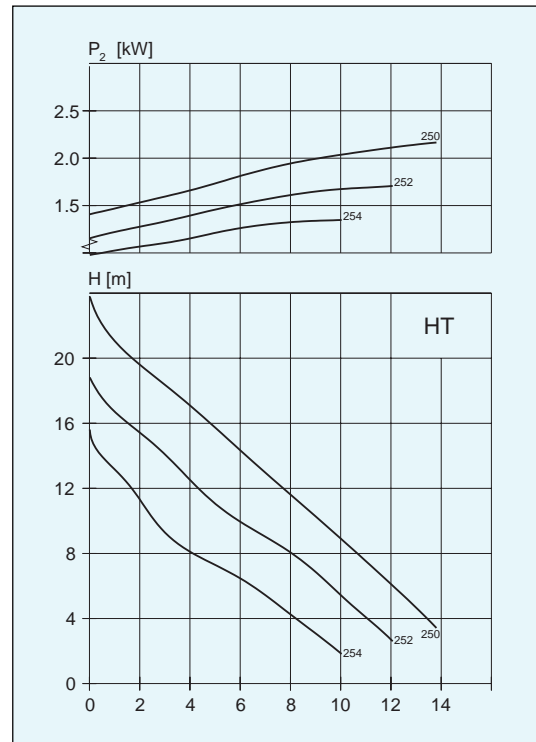

Impeller code	No. of vanes	Outlet dia mm CP vers.	Through-let, mm	Motor rating kW		rpm	Available versions
				P ₁	P ₂		
W250	1	50	48	3.1	2.4	2685	CP/CF/CS
250	1	50	48	2.3	1.7	2685	CP/CF/CS
W252	1	50	48	3.1	2.4	2685	CP/CF/CS
252	1	50	48	2.3	1.7	2685	CP/CF/CS
252*	1	50	48	2.1	1.5	2685	CP/CF/CS
W254	1	50	48	3.1	2.4	2685	CP/CF/CS
254	1	50	48	2.3	1.7	2685	CP/CF/CS
254*	1	50	48	2.1	1.5	2685	CP/CF/CS

* Single phase
W=Also available in a warm liquid version

C 3067

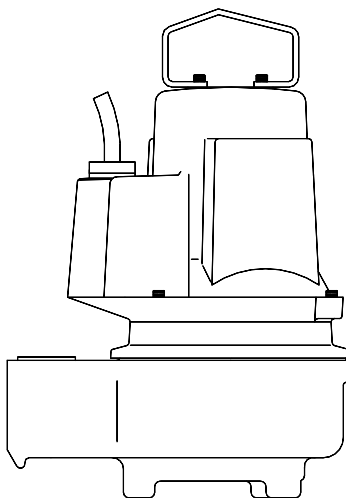

Weight kg	CP	CF	CH	CS
HT	39	40	39	49

CP/CF/CH/CS

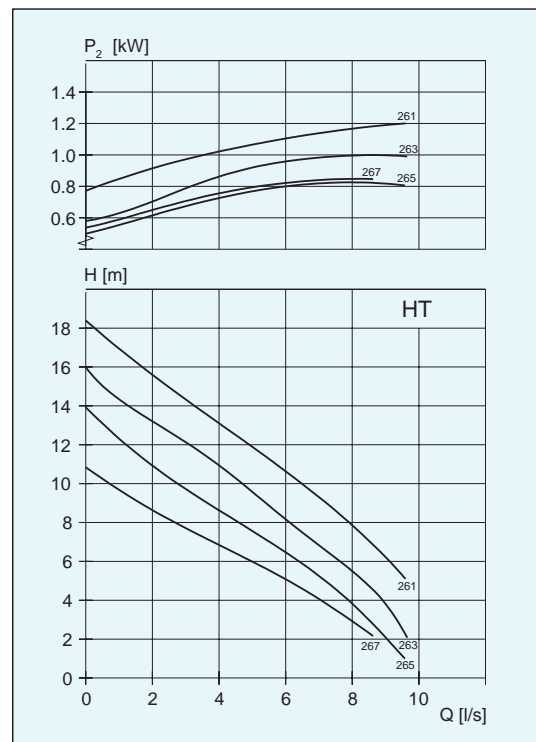

Impeller code	No. of vanes	Outlet dia mm CP vers.	Through-let, mm	Motor rating kW		rpm	Available versions
				P ₁	P ₂		
W261*	1	50	34	1.6	1.2	2820	CP/CF/CH/CS
W263*	1	50	34	1.6	1.2	2820	CP/CF/CH/CS
W265*	1	50	34	1.6	1.2	2820	CP/CF/CH/CS
W267*	1	50	34	1.6	1.2	2820	CP/CF/CH/CS
263**	1	50	34	1.5	1.0	2835	CP/CF/CH/CS

* NEVACLOG
** Single phase

C 3085

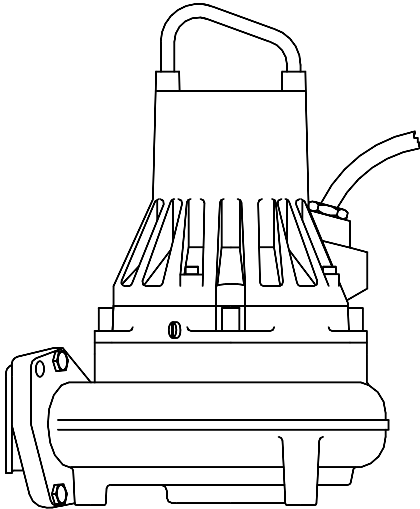

Weight, kg	CP	CF	CS	CT/CZ
LT	78	-	73	-
MT	66	68	71	88
HT	62	-	63	-

CP/CF/CS/CT/CZ

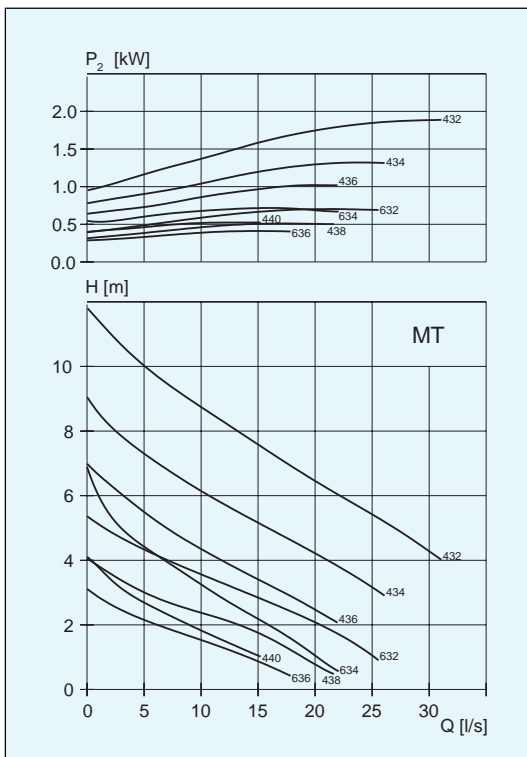

Impeller code	No. of vanes	Outlet dia mm CP vers.	Through-let, mm	Motor rating kW P ₁ P ₂	rpm	Available versions
W• 432*	1	80	∅ 76	2.7 2.0	1395	CP/CS/CF
W• 434*	1	80	∅ 76	2.7 2.0	1395	CP/CS/CF
W• 434*	1	80	∅ 76	1.8 1.3	1385	CP/CS/CF
434*	1	80	∅ 76	1.8 1.4	1430	CT/CZ
W• 436*	1	80	∅ 76	2.7 2.0	1395	CP/CS/CF
W• 436*	1	80	∅ 76	1.8 1.3	1385	CP/CS/CF
436*	1	80	∅ 76	1.8 1.4	1435	CT/CZ
436*	1	80	∅ 76	1.4 1.0	1420	CT/CZ
W• 438	1	80	64 x 86	2.7 2.0	1395	CP/CS/CF
W• 438	1	80	64 x 86	1.8 1.3	1385	CP/CS/CF
438	1	80	64 x 86	1.8 1.4	1430	CT/CZ
438	1	80	64 x 86	1.4 1.0	1415	CT/CZ
W• 440	1	80	64 x 95	2.7 2.0	1395	CP/CF/CS
W• 440	1	80	64 x 95	1.8 1.3	1385	CP/CF/CS
440	1	80	64 x 95	1.8 1.4	1430	CT/CZ
440	1	80	64 x 95	1.4 1.0	1415	CT/CZ
• 632*	1	80	∅ 76	1.3 0.9	940	CP/CF/CS
634*	1	80	∅ 76	1.3 0.9	940	CP/CF/CS
636*	1	80	∅ 76	1.3 0.9	940	CP/CF/CS
Single phase						
• 434	1	80	∅ 76	2.0 1.5	1440	CP/CF/CS
• 436	1	80	∅ 76	2.0 1.5	1440	CP/CF/CS
• 436	1	80	∅ 76	1.4 0.95	1440	CP/CF/CS
• 438	1	80	64 x 86	2.0 1.5	1440	CP/CF/CS
• 438	1	80	64 x 86	1.4 0.95	1440	CP/CF/CS
• 440	1	80	64 x 95	2.0 1.5	1440	CP/CF/CS
• 440	1	80	64 x 95	1.4 0.95	1440	CP/CF/CS

• Can be equipped with flush valve * NEVACLOG

CP/CS/CT/CZ

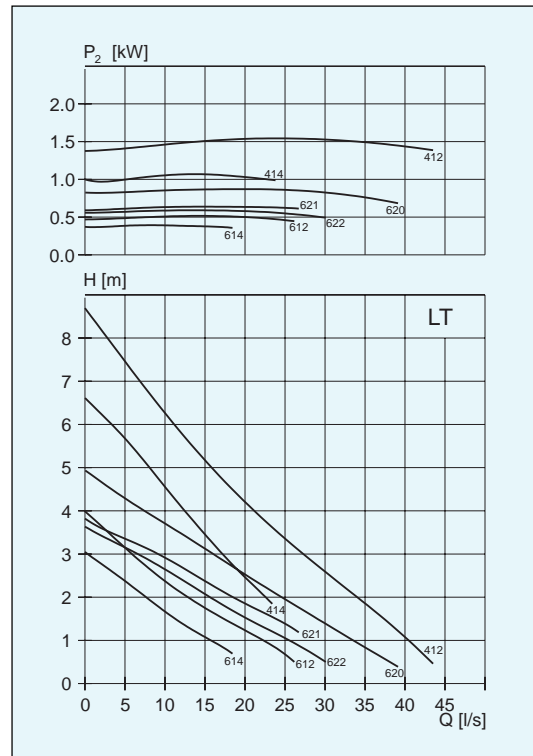

Impeller code	No. of vanes	Outlet dia mm CP vers.	Through-let, mm	Motor rating kW		rpm	Available versions
				P ₁	P ₂		
W• 412	1	100	∅ 100	2.7	2.0	1395	CP/CS
W• 414	1	100	80 x 100	2.7	2.0	1395	CP/CS
W• 414	1	100	80 x 100	1.8	1.3	1385	CP/CS
• 414	1	100	80 x 100	1.8	1.4	1430	CT/CZ
612	1	100	∅ 100	1.3	0.9	940	CP/CS
614	1	100	80 x 100	1.3	0.9	940	CP/CS
• 620	1	100	∅ 100	1.3	0.9	940	CP/CS
621	1	100	∅ 100	1.3	0.9	940	CP/CS
622	1	100	∅ 100	1.3	0.9	940	CP/CS

• Can be equipped with flush valve

CP/CS

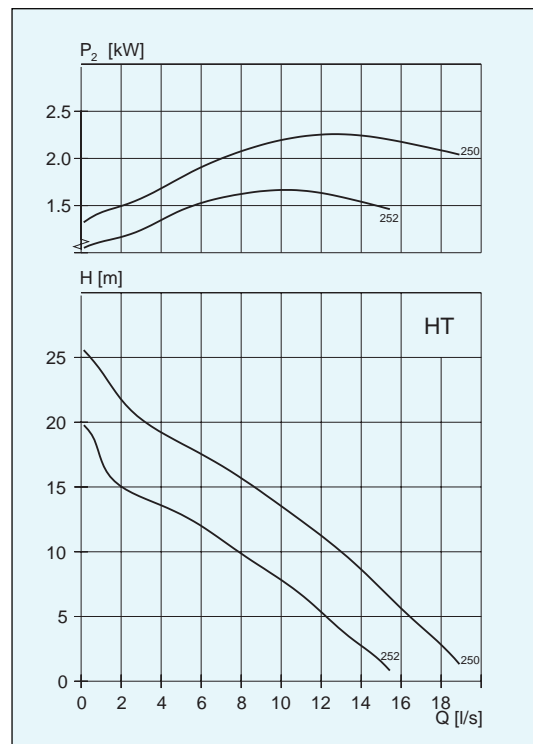

Impeller code	No. of vanes	Outlet dia mm CP vers.	Through-let, mm	Motor rating kW		rpm	Available versions
				P ₁	P ₂		
• 250	1	80	40 x 40	3.0	2.4	2830	CP/CS
• 252	1	80	40 x 40	3.0	2.4	2830	CP/CS

• Can be equipped with flush valve

C 3102

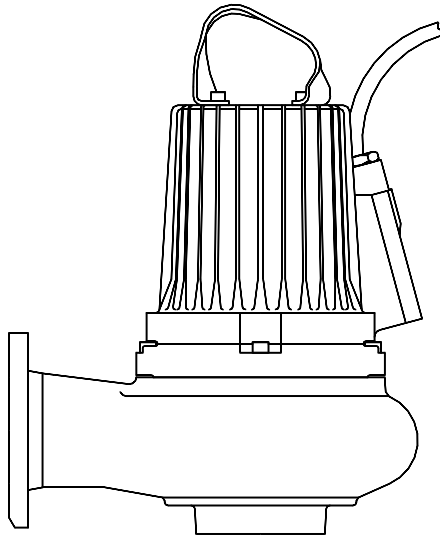

Weight, kg	CP	CT/CZ	CS
LT	117	163	135
MT	112	132	121
HT	105	-	114

- Can be equipped with flush valve.
- * NEVACLOG

CP/CS/CT/CZ

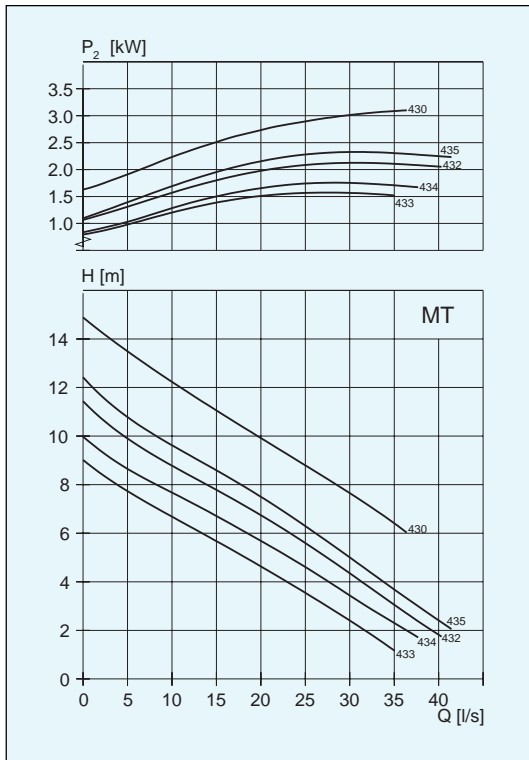

Impeller code	No. of vanes	Outlet dia mm CP vers.	Through-let, mm	Motor rating kW		rpm	Available versions
				P ₁	P ₂		
W• 430*	1	100	∅ 76	3.8	3.1	1440	CP/CS
W• 432*	1	100	∅ 76	3.8	3.1	1440	CP/CS
W• 433*	1	100	∅ 76	3.8	3.1	1440	CP/CS
W• 434*	1	100	∅ 76	3.8	3.1	1440	CP/CS
W• 435*	1	100	∅ 76	3.8	3.1	1440	CP/CS
432	1	100	∅ 76	2.9	2.4	1455	CT/CZ
433	1	100	∅ 76	2.9	2.4	1455	CT/CZ
434	1	100	∅ 76	2.9	2.4	1455	CT/CZ
435	1	100	∅ 76	2.9	2.4	1455	CT/CZ

CP/CS/CT/CZ

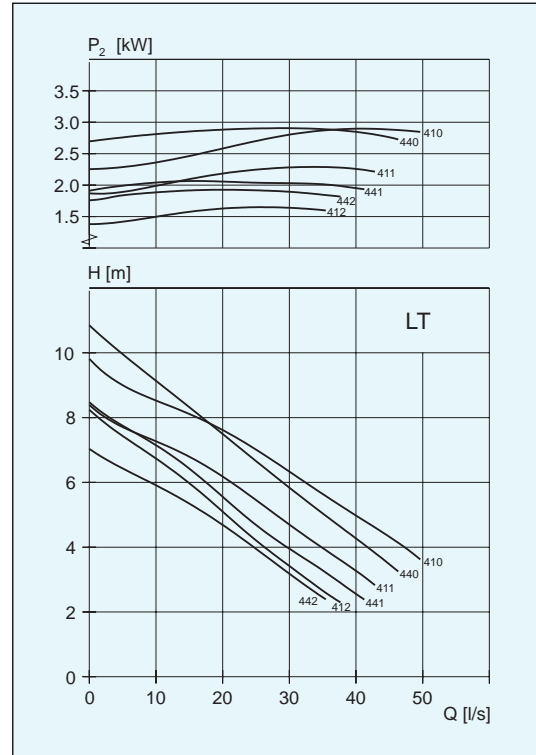

Impeller code	No. of vanes	Outlet dia mm CP vers.	Through-let, mm	Motor rating kW		rpm	Available versions
				P ₁	P ₂		
W• 410	2	100/150	55 x 100	3.8	3.1	1435	CP/CS
W• 411	2	100/150	52 x 96	3.8	3.1	1435	CP/CS
W• 412	2	100/150	54 x 88	3.8	3.1	1435	CP/CS
W• 440	1	100/150	∅ 100	3.8	3.1	1435	CP/CS
W• 441	1	100/150	∅ 100	3.8	3.1	1435	CP/CS
W• 442	1	100/150	∅ 100	3.8	3.1	1435	CP/CS
411	2	100/150	52 x 96	2.9	2.4	1450	CT/CZ
412	2	100/150	54 x 88	2.9	2.4	1450	CT/CZ
441	1	100/150	∅ 100	2.9	2.4	1450	CT/CZ
442	1	100/150	∅ 100	2.9	2.4	1450	CT/CZ

CP/CS

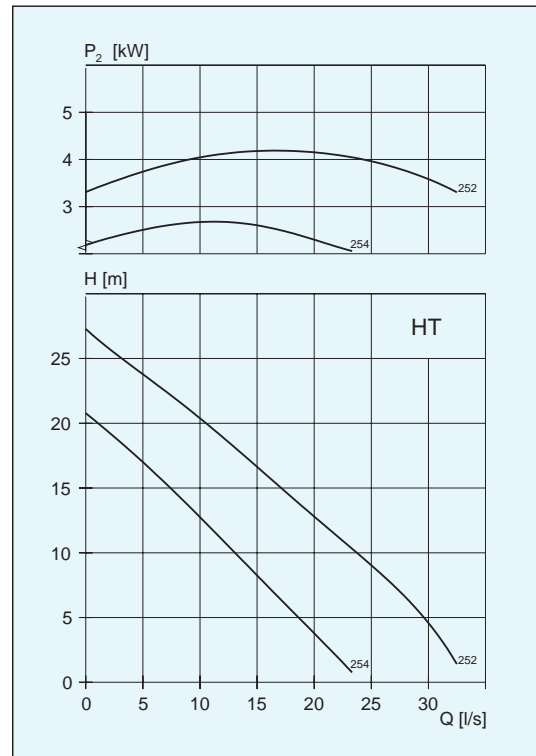

Impeller code	No. of vanes	Outlet dia mm CP vers.	Through-let, mm	Motor rating kW		rpm	Available versions
				P ₁	P ₂		
• 252	1	80	∅ 52	5.4	4.4	2870	CP/CS
• 254	1	80	∅ 52	5.4	4.4	2870	CP/CS

C 3127

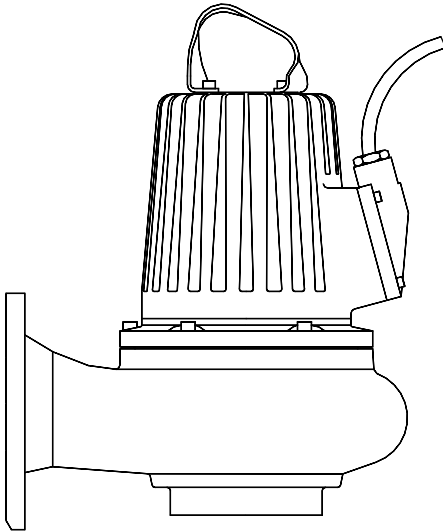

Weight, kg	CP	CT/CZ	CS
LT	154	221	181
MT	142	188	158

CP/CS/CT/CZ

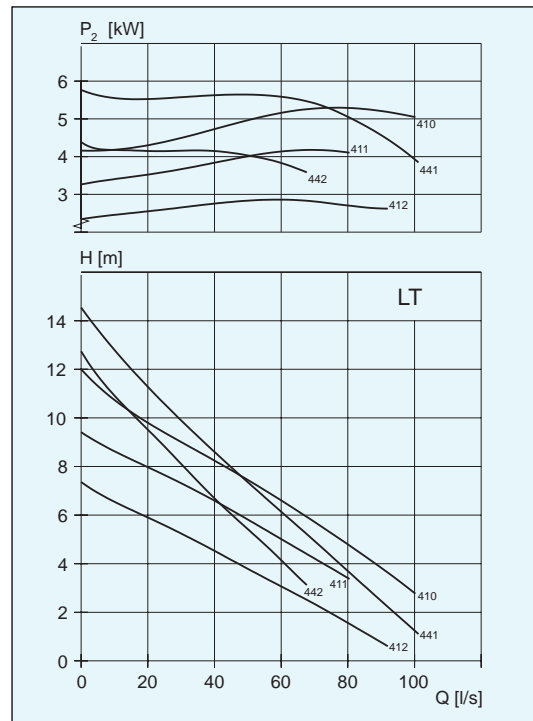

CP/CS/CT/CZ

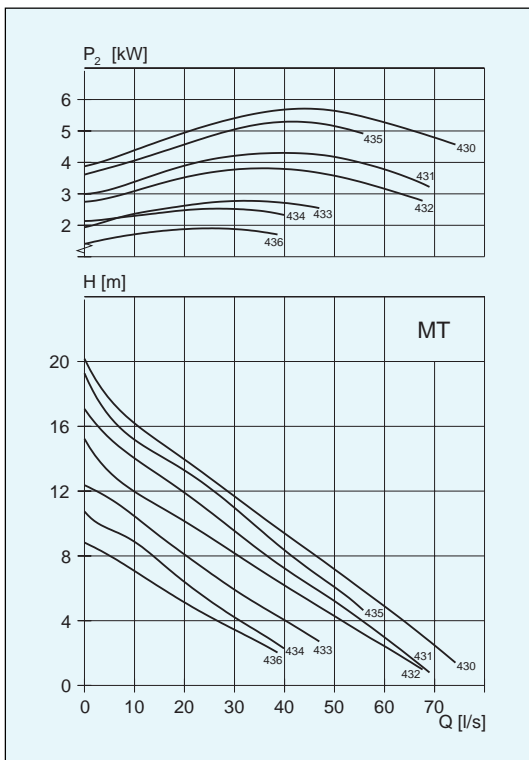

Impeller code	No. of vanes	Outlet dia mm CP vers.	Through-let, mm	Motor rating kW		rpm	Available versions
				P ₁	P ₂		
W•410	2	200	∅76	7.0	5.9	1450	CP/CS
W•411	2	200	∅76	7.0	5.9	1450	CP/CS
•411	2	200	∅76	5.7	4.7	1450	CP/CS
W•412	2	200	∅76	7.0	5.9	1450	CP/CS
•412	2	200	∅76	5.7	4.7	1450	CP/CS
W•441	1	200	107x117	7.0	5.9	1450	CP/CS
W•442	1	200	∅76	7.0	5.9	1450	CP/CS
•442	1	200	∅76	5.7	4.7	1450	CP/CS
411	2	200	∅76	5.6	4.7	1460	CT/CZ
412	2	200	∅76	4.8	4.0	1460	CT/CZ
412	2	200	∅76	5.6	4.7	1460	CT/CZ
442	1	200	∅76	4.8	4.0	1460	CT/CZ
442	1	200	∅76	5.6	4.7	1460	CT/CZ

Impeller code	No. of vanes	Outlet dia mm CP vers.	Through-let, mm	Motor rating kW		rpm	Available versions
				P ₁	P ₂		
W•430	1	100/150	100x110	7.1	5.9	1445	CP/CS
W•431	1	100/150	90x100	7.1	5.9	1445	CP/CS
•431	1	100/150	90x100	5.7	4.7	1445	CP/CS
W•432	1	100/150	87x100	7.1	5.9	1445	CP/CS
•432	1	100/150	87x100	5.7	4.7	1445	CP/CS
W•433	1	100/150	82x100	7.1	5.9	1445	CP/CS
•433	1	100/150	82x100	5.7	4.7	1445	CP/CS
W•434	1	100/150	80x100	7.1	5.9	1445	CP/CS
•434	1	100/150	80x100	5.7	4.7	1445	CP/CS
W•435	1	100/150	∅100	7.1	5.9	1445	CP/CS
W•436	1	100/150	∅100	7.1	5.9	1445	CP/CS
•436	1	100/150	∅100	5.7	4.7	1445	CP/CS
•431	1	100/150	90x100	5.6	4.7	1460	CT/CZ
•432	1	100/150	87x100	5.6	4.7	1460	CT/CZ
•432	1	100/150	87x100	4.8	4.0	1455	CT/CZ
•433	1	100/150	82x100	5.6	4.7	1460	CT/CZ
•433	1	100/150	82x100	4.8	4.0	1455	CT/CZ
•434	1	100/150	80x100	5.6	4.7	1460	CT/CZ
•434	1	100/150	80x100	4.8	4.0	1455	CT/CZ
•436	1	100/150	∅100	5.6	4.7	1460	CT/CZ
•436	1	100/150	∅100	4.8	4.0	1455	CT/CZ

• Can be equipped with flush valve. * NEVACLOG

C 3127

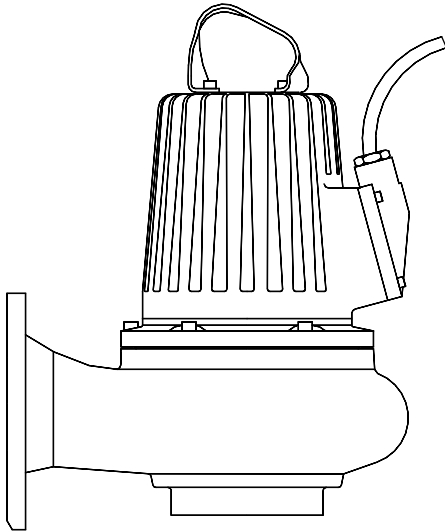

Weight, kg	CP	CT/CZ	CS
HT	136	156	142
SH	136	-	142

CP/CS/CT/CZ

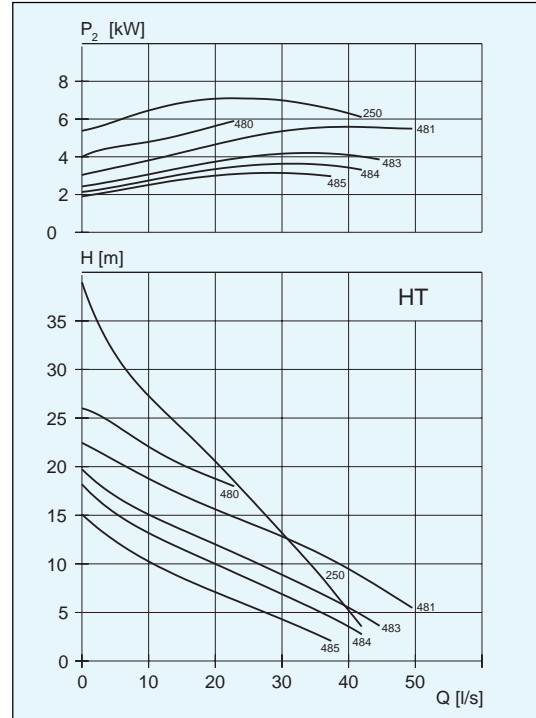

CP/CS

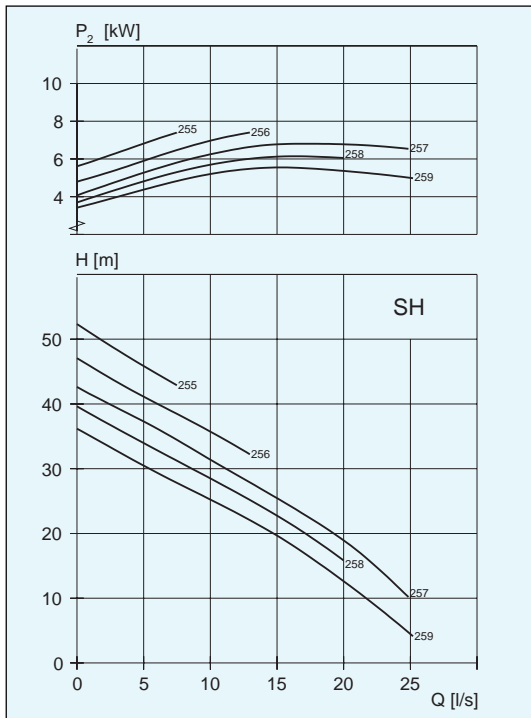

Impeller code	No. of vanes	Outlet dia mm CP vers.	Through-let, mm	Motor rating kW		rpm	Available versions
				P ₁	P ₂		
•250	1	80	∅ 58	8.7	7.4	2900	CP/CS
W•480*	1	100	∅ 76	7.1	5.9	1445	CP/CS
W•481*	1	100	∅ 76	7.1	5.9	1445	CP/CS
W•483*	1	100	∅ 76	7.1	5.9	1445	CP/CS
•483*	1	100	∅ 76	5.7	4.7	1445	CP/CS
W•484*	1	100	∅ 76	7.1	5.9	1445	CP/CS
•484*	1	100	∅ 76	5.7	4.7	1445	CP/CS
W•485*	1	100	∅ 76	7.1	5.9	1445	CP/CS
•485*	1	100	∅ 76	5.7	4.7	1445	CP/CS
•483*	1	100	∅ 76	5.6	4.7	1460	CT/CZ
•484*	1	100	∅ 76	5.6	4.7	1460	CT/CZ
•484*	1	100	∅ 76	4.8	4.0	1460	CT/CZ
•485*	1	100	∅ 76	5.6	4.7	1460	CT/CZ
•485*	1	100	∅ 76	4.8	4.0	1460	CT/CZ

• Can be equipped with flush valve. * NEVACLOG

Impeller code	No. of vanes	Outlet dia mm CP vers.	Through-let, mm	Motor rating kW		rpm	Available versions
				P ₁	P ₂		
•255	1	80	40 x 40	8.7	7.4	2900	CP/CS
•256	1	80	40 x 40	8.7	7.4	2900	CP/CS
•257	1	80	40 x 40	8.7	7.4	2900	CP/CS
•258	1	80	40 x 40	8.7	7.4	2900	CP/CS
•259	1	80	40 x 40	8.7	7.4	2900	CP/CS

C 3140

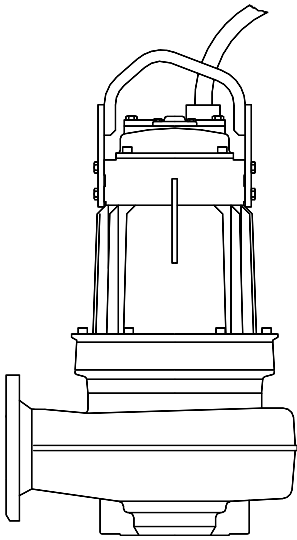

Weight, kg	CP	CS
LT	378	436
MT	283	364
HT	283	310

• Can be equipped with flush valve.

CP/CS

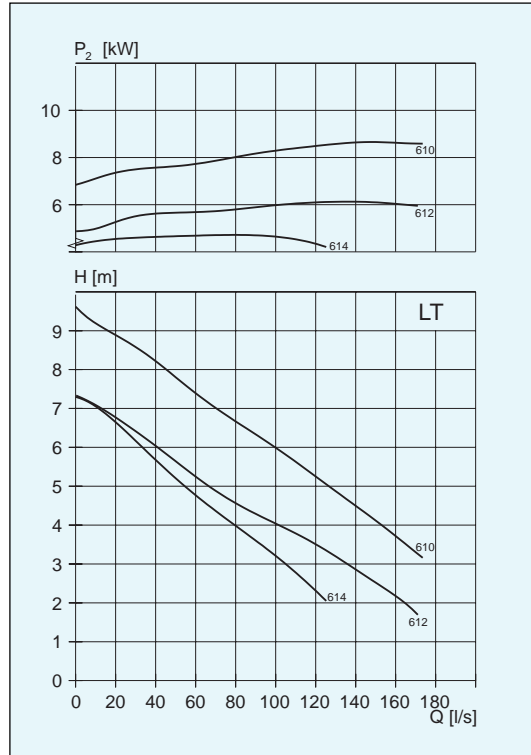

Impeller code	No. of vanes	Outlet dia mm CP vers.	Through-let, mm	Motor rating kW		rpm	Available versions
				P ₁	P ₂		
•610	2	250	102 x 110	10.5	8.8	955	CP/CS
•612	2	250	102 x 110	10.5	8.8	955	CP/CS
•614	2	250	82 x 95	10.5	8.8	955	CP/CS

CP/CS

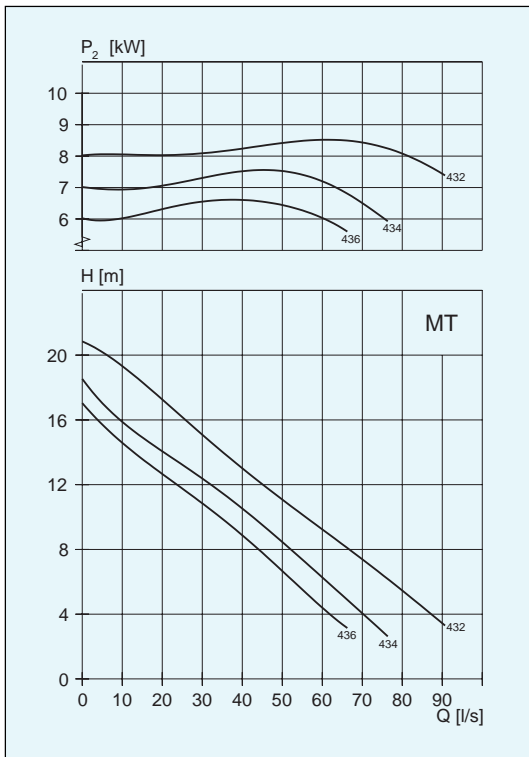

Impeller code	No. of vanes	Outlet dia mm CP vers.	Through-let, mm	Motor rating kW		rpm	Available versions
				P ₁	P ₂		
•432	1	150	100 x 109	10.7	9	1455	CP/CS
•434	1	150	100 x 100	10.7	9	1455	CP/CS
•436	1	150	93 x 100	10.7	9	1455	CP/CS

CP/CS

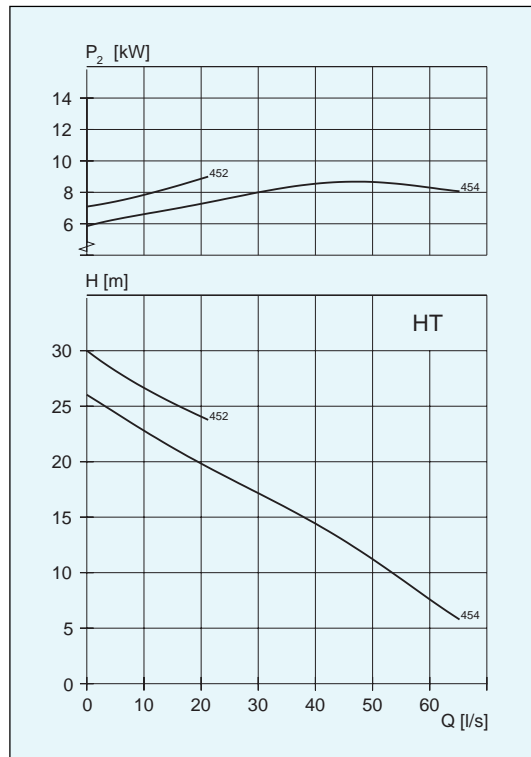

Impeller code	No. of vanes	Outlet dia mm CP vers.	Through-let, mm	Motor rating kW		rpm	Available versions
				P ₁	P ₂		
•452	1	100	∅76	10.7	9	1455	CP/CS
•454	1	100	∅76	10.7	9	1455	CP/CS

C 3152

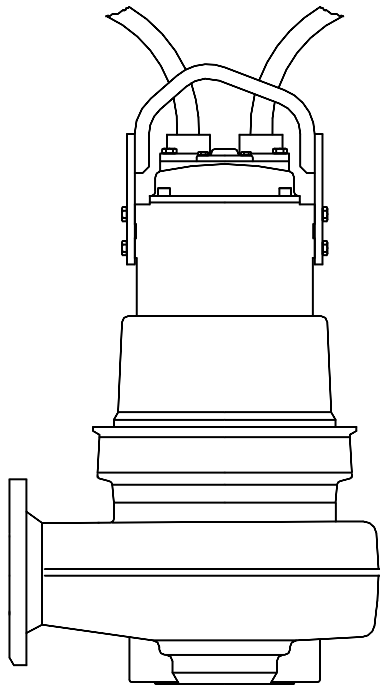

Weight, kg (with cooling jacket)	CP	CS	CT/CZ
LT	368	425	466
MT	279	320	348
HT	270	289	314

CP/CS/CT/CZ

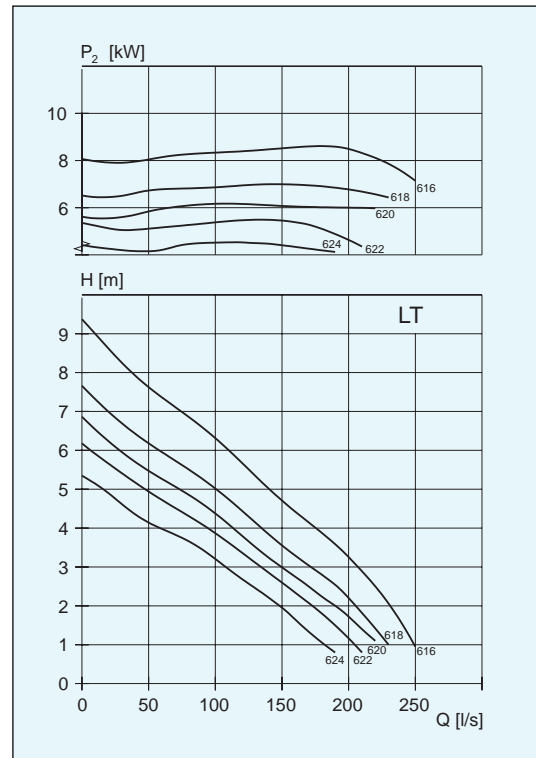

Impeller code	No. of vanes	Outlet dia mm CP vers.	Through-let, mm	Motor rating kW		rpm	Available versions
				P ₁	P ₂		
W• 616	2	300	102 x 102	10.5	8.8	955	CP/CS/CT/CZ
W• 618	2	300	102 x 102	10.5	8.8	955	CP/CS/CT/CZ
W• 620	2	300	102 x 102	10.5	8.8	955	CP/CS/CT/CZ
W• 622	2	300	102 x 102	10.5	8.8	955	CP/CS/CT/CZ
W• 624	2	300	102 x 102	10.5	8.8	955	CP/CS/CT/CZ

• Can be equipped with flush valve

CP/CS/CT/CZ

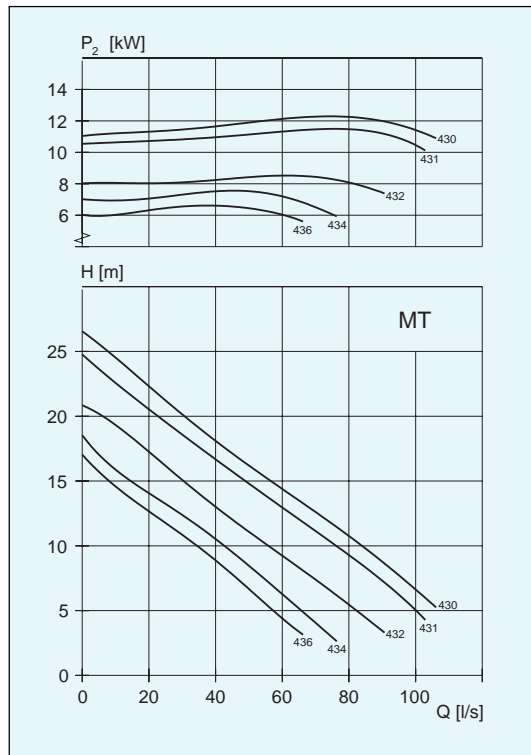

Impeller code	No. of vanes	Outlet dia mm CP vers.	Through-let, mm	Motor rating kW		rpm	Available versions
				P ₁	P ₂		
• 430	1	200	100 x 115	15.8	13.5	1450	CP/CS/CT/CZ
W• 431	1	200	100 x 110	15.8	13.5	1450	CP/CS/CT/CZ
W• 432	1	200	109 x 100	15.8	13.5	1450	CP/CS/CT/CZ
• 432	1	200	109 x 100	10.7	9	1455	CP/CS/CT/CZ
W• 434	1	200	100 x 100	15.8	13.5	1450	CP/CS/CT/CZ
• 434	1	200	100 x 100	10.7	9	1455	CP/CS/CT/CZ
W• 436	1	200	100 x 93	15.8	13.5	1450	CP/CS/CT/CZ
• 436	1	200	100 x 93	10.7	9	1455	CP/CS/CT/CZ

• Can be equipped with flush valve

CP/CS/CT/CZ

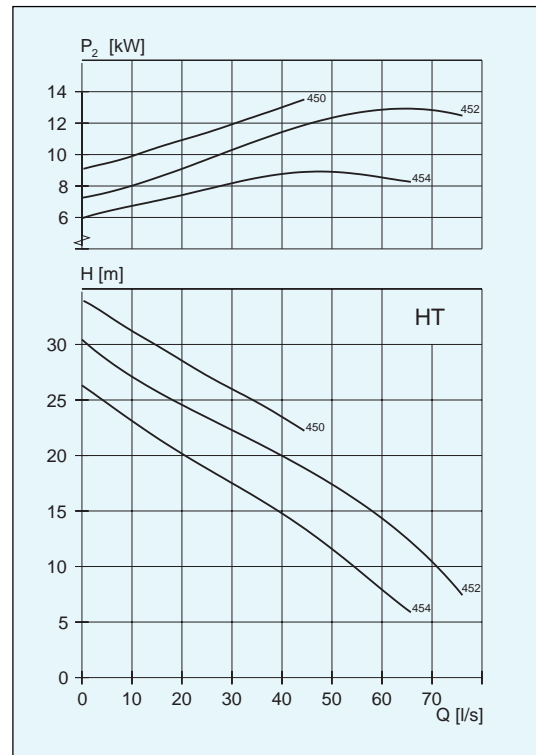

Impeller code	No. of vanes	Outlet dia mm CP vers.	Through-let, mm	Motor rating kW		rpm	Available versions
				P ₁	P ₂		
W• 450	1	100/150	∅ 76	15.8	13.5	1450	CP/CS/CT/CZ
W• 452	1	100/150	∅ 76	15.8	13.5	1450	CP/CS/CT/CZ
W• 454	1	100/150	∅ 76	15.8	13.5	1450	CP/CS/CT/CZ
• 454	1	100/150	∅ 76	10.7	9	1455	CP/CS/CT/CZ

• Can be equipped with flush valve

C 3152 SH

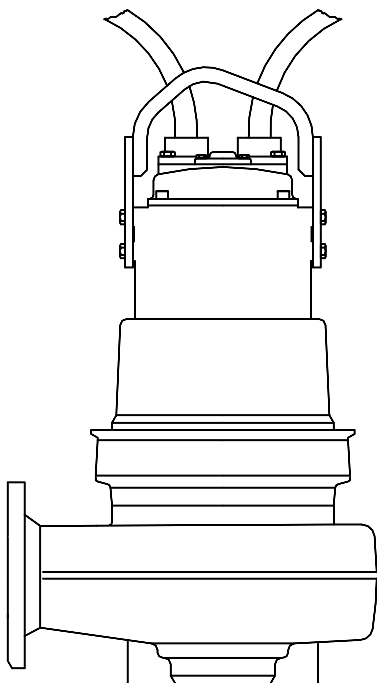

Weight, kg (with cooling jacket)	CP	CS	CT/CZ
SH	262	261	266

CP/CS/CT/CZ

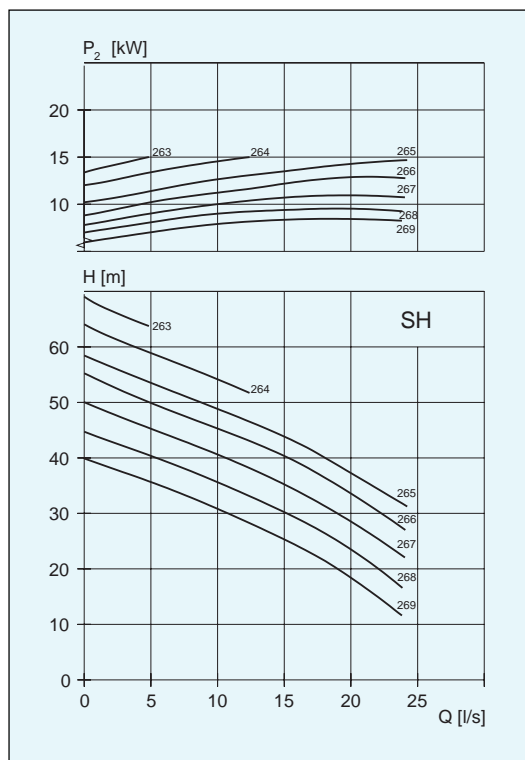

Impeller code	No. of vanes	Outlet dia mm CP vers.	Through-let, mm	Motor rating kW		rpm	Available versions
				P ₁	P ₂		
•263	1	100	40 x 40	17.0	15	2920	CP/CS/CT/CZ
•264	1	100	40 x 40	17.0	15	2920	CP/CS/CT/CZ
•265*	1	100	40 x 40	17.0	15	2920	CP/CS/CT/CZ
•266*	1	100	40 x 40	17.0	15	2920	CP/CS/CT/CZ
•267*	1	100	40 x 40	17.0	15	2920	CP/CS/CT/CZ
•268*	1	100	40 x 40	17.0	15	2920	CP/CS/CT/CZ
•269*	1	100	40 x 40	17.0	15	2920	CP/CS/CT/CZ

* NPSH_{re} = 11 m at 20 l/s • Can be equipped with flush valve

C 3170

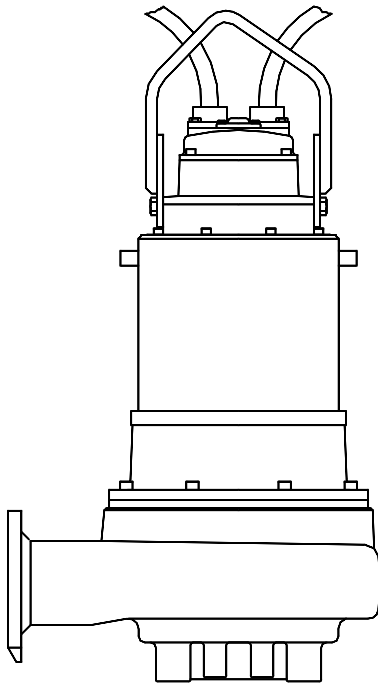

Weight, kg (with cooling jacket)	CP	CS	CT/CZ
LT	575	615	670
MT	522	542	572
HT	480	527	530

CP/CS/CT/CZ

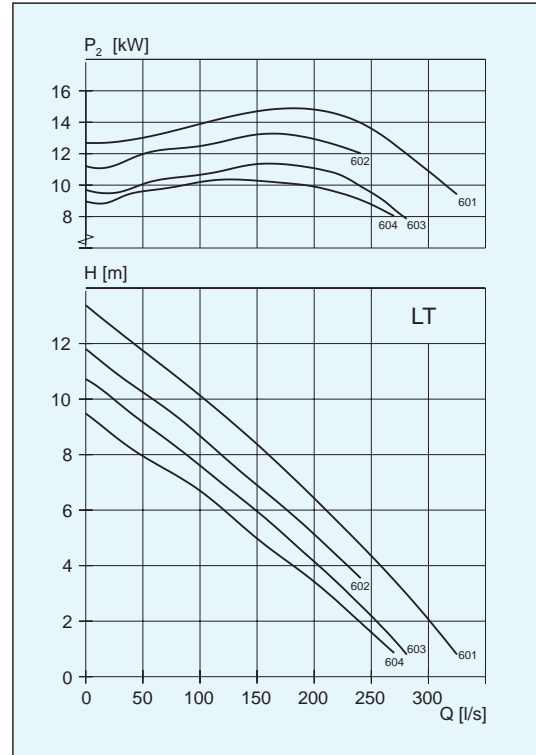

Impeller code	No. of vanes	Outlet dia mm CP vers.	Through-let, mm	Motor rating kW		rpm	Available versions
				P ₁	P ₂		
W•601	2	250	102x102	17.5	15	970	CP/CS/CT/CZ
W•602	2	250	102x102	17.5	15	970	CP/CS/CT/CZ
W•603	2	250	102x102	17.5	15	970	CP/CS/CT/CZ
W•604	2	250	102x102	17.5	15	970	CP/CS/CT/CZ

• Can be equipped with flush valve

CP/CS/CT/CZ

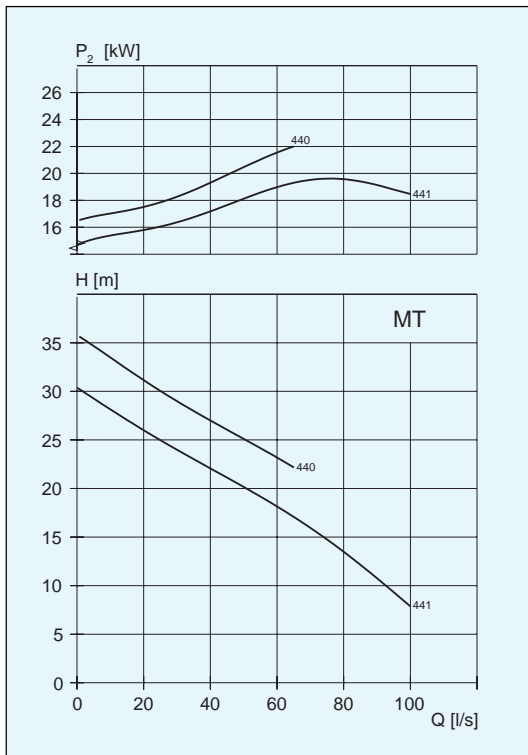

Impeller code	No. of vanes	Outlet dia mm CP vers.	Through-let, mm	Motor rating kW		rpm	Available versions
				P ₁	P ₂		
W•440	1	200	∅100	25	22	1460	CP/CS/CT/CZ
W•441	1	200	∅100	25	22	1460	CP/CS/CT/CZ

CP/CS/CT/CZ

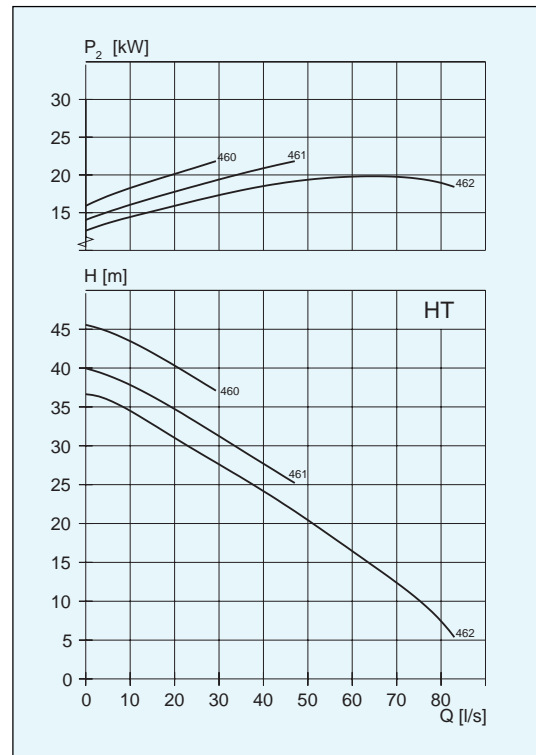

Impeller code	No. of vanes	Outlet dia mm CP vers.	Through-let, mm	Motor rating kW		rpm	Available versions
				P ₁	P ₂		
W•460	1	150	77x80	25	22	1460	CP/CS/CT/CZ
W•461	1	150	77x80	25	22	1460	CP/CS/CT/CZ
W•462	1	150	∅77	25	22	1460	CP/CS/CT/CZ

C 3201

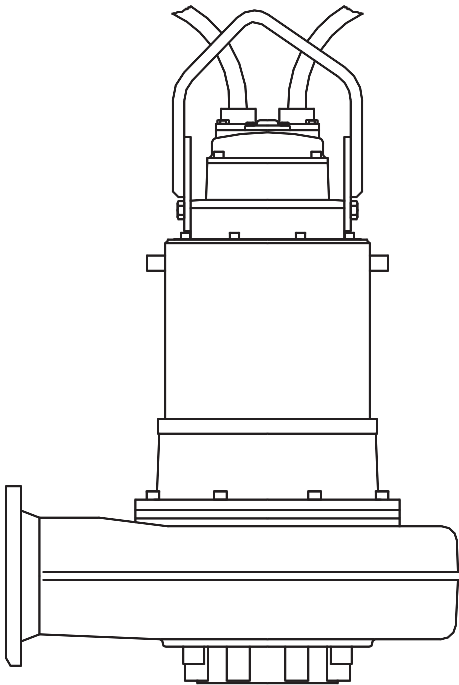

Weight, kg (with cooling jacket)	CP	CS	CT/CZ
LT	671	786	917
MT	570	598	635
HT	525	535	530

• Can be equipped with flush valve

CP/CT/CS

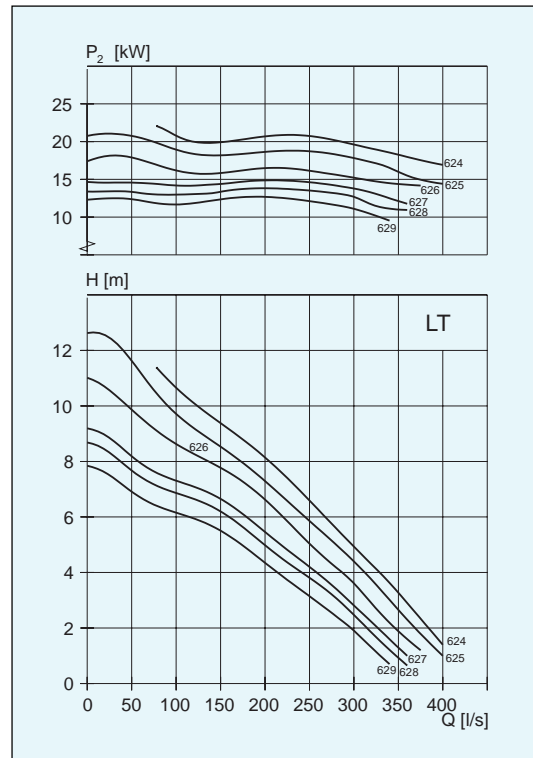

Impeller code	No. of vanes	Outlet dia mm CP vers.	Through-let, mm	Motor rating kW		rpm	Available versions
				P ₁	P ₂		
W•624	3	300/350	102 x 102	25	22	970	CP/CS/CT/CZ
W•625	3	300/350	102 x 102	25	22	970	CP/CS/CT/CZ
W•626	3	300/350	102 x 102	25	22	970	CP/CS/CT/CZ
W•627	3	300/350	102 x 102	25	22	970	CP/CS/CT/CZ
W•628	3	300/350	102 x 102	25	22	970	CP/CS/CT/CZ
W•629	3	300/350	102 x 102	25	22	970	CP/CS/CT/CZ

CP/CS/CT/CZ

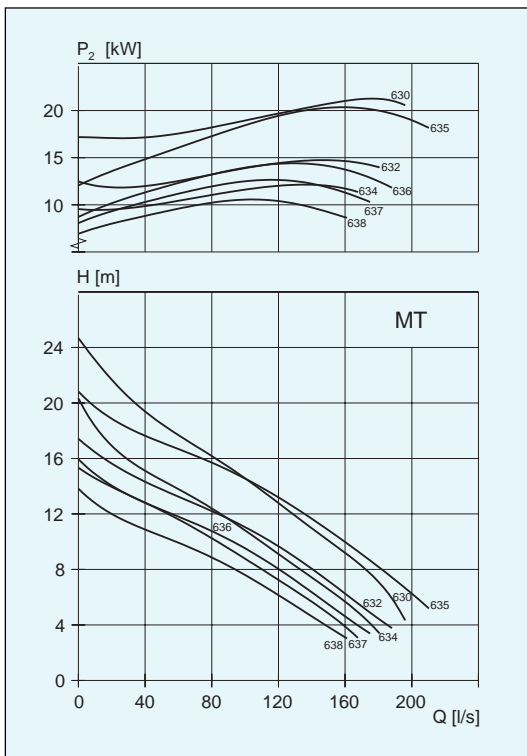

Impeller code	No. of vanes	Outlet dia mm CP vers.	Through-let, mm	Motor rating kW		rpm	Available versions
				P ₁	P ₂		
W•630	1	250	144 x 120	25	22	970	CP/CS/CT/CZ
W•632	1	250	144 x 120	25	22	970	CP/CS/CT/CZ
W•634	1	250	144 x 120	25	22	970	CP/CS/CT/CZ
W•635	2	250	102 x 84	25	22	970	CP/CS/CT/CZ
W•636	2	250	102 x 84	25	22	970	CP/CS/CT/CZ
W•637	2	250	102 x 84	25	22	970	CP/CS/CT/CZ
W•638	2	250	102 x 84	25	22	970	CP/CS/CT/CZ

CP/CS/CT/CZ

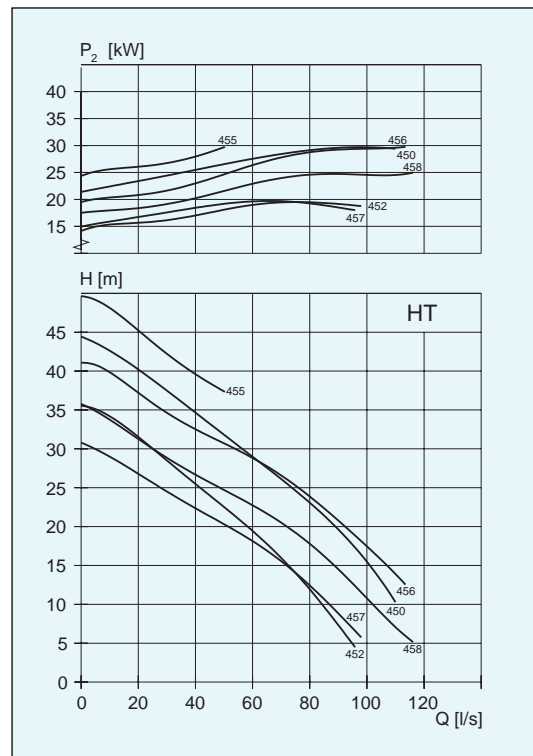

Impeller code	No. of vanes	Outlet dia mm CP vers.	Through-let, mm	Motor rating kW		rpm	Available versions
				P ₁	P ₂		
•450	1	200	77 x 80	34	30	1455	CP/CS/CT/CZ
W•452	1	200	77 x 77	34	30	1455	CP/CS/CT/CZ
•452	1	200	77 x 77	25	22	1460	CP/CS/CT/CZ
•455	1	200	∅ 100	34	30	1455	CP/CS/CT/CZ
•456	1	200	∅ 100	34	30	1455	CP/CS/CT/CZ
W•457	1	200	∅ 100	34	30	1455	CP/CS/CT/CZ
•457	1	200	∅ 100	25	22	1460	CP/CS/CT/CZ
W•458	1	200	∅ 100	34	30	1455	CP/CS/CT/CZ
•458	1	200	∅ 100	25	22	1460	CP/CS/CT/CZ

C 3201 SH

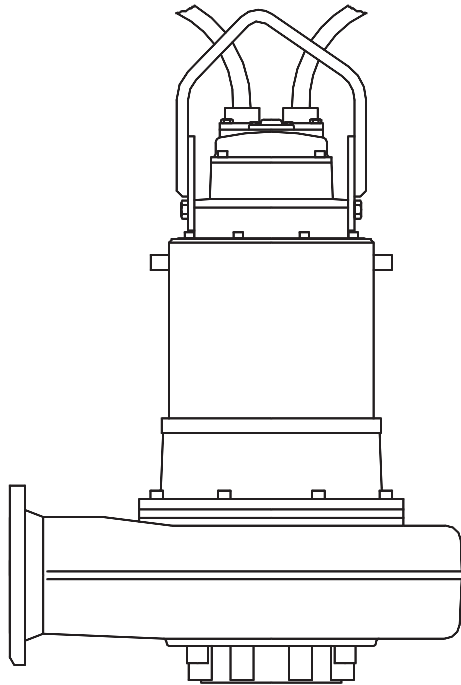

Weight, kg (with cooling jacket)	CP	CS	CT/CZ
SH	490	489	538

CP/CS/CT/CZ

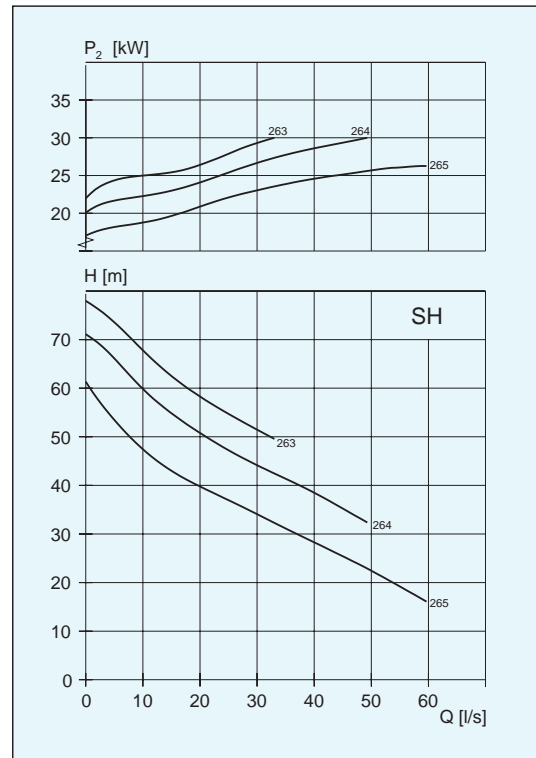

Impeller code	No. of vanes	Outlet dia mm CP vers.	Through-let, mm	Motor rating kW		rpm	Available versions
				P_1	P_2		
•263 *	1	100	∅76	34	30	2300	CP/CS/CT/CZ
•264 *	1	100	∅76	34	30	2300	CP/CS/CT/CZ
•265 ¹⁾	1	100	∅76	34	30	2300	CP/CS/CT/CZ

¹⁾ NPSH_{re} = 11 m at 51 l/s

- Can be equipped with flush valve
- * NEVACLOG

C 3300

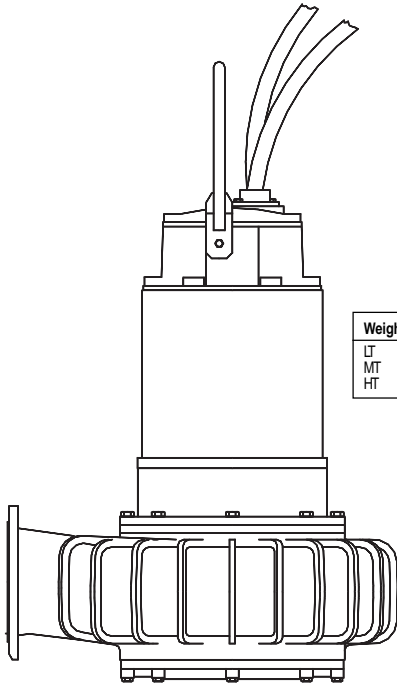

Weight, kg	CP	CS	CT/CZ
LT	1060	1175	1308
MT	1075	1188	1321
HT	900	963	1022

CP/CS/CT/CZ

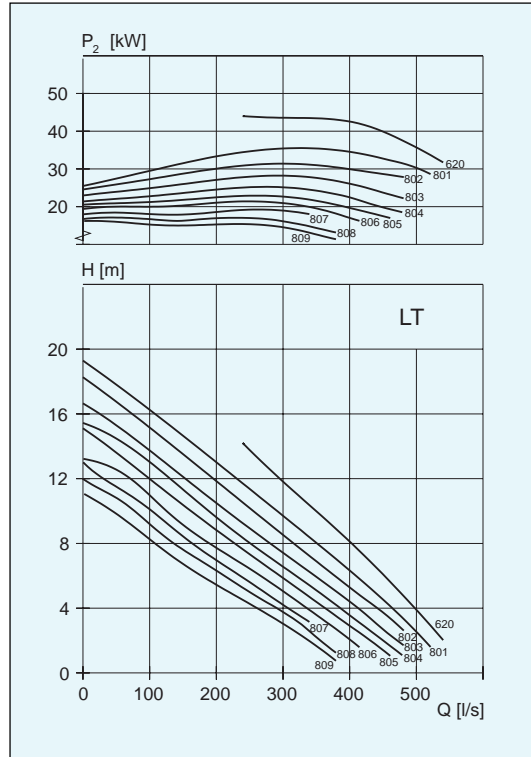

Impeller code	No. of vanes	Outlet dia mm CP vers.	Through-let, mm	Motor rating kW		rpm	Available versions
				P ₁	P ₂		
• 801-809	3	350	102 x 102	43	37	730	CP/CS/CT/CZ
• 804-809	3	350	102 x 102	31	27	730	CP/CS/CT/CZ
• 620	3	350	102 x 102	50	44	975	CP/CS/CT/CZ

CP/CS/CT/CZ

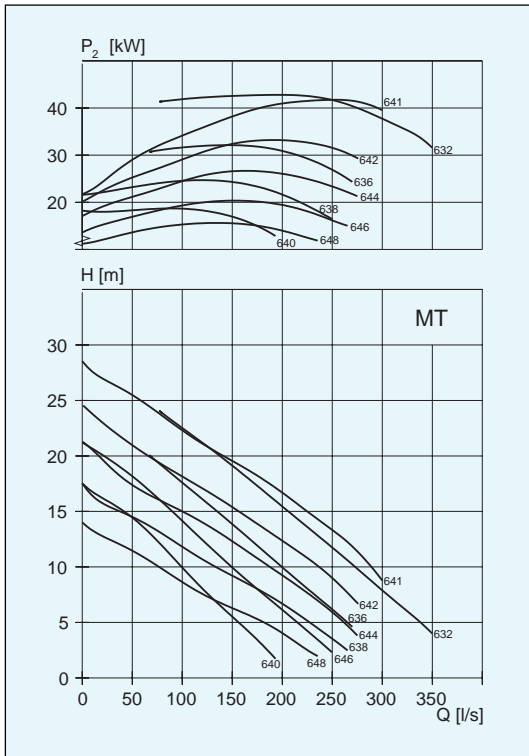

Impeller code	No. of vanes	Outlet dia mm CP vers.	Through-let, mm	Motor rating kW		rpm	Available versions
				P ₁	P ₂		
• 632	1	300	∅ 190	50	44	975	CP/CS/CT/CZ
• 636	1	300	176 x 100	50	44	975	CP/CS/CT/CZ
• 636	1	300	176 x 180	39	34	975	CP/CS/CT/CZ
• 638	1	300	150 x 100	50	44	975	CP/CS/CT/CZ
• 638	1	300	150 x 180	39	34	975	CP/CS/CT/CZ
• 640	1	300	134 x 100	50	44	975	CP/CS/CT/CZ
• 640	1	300	134 x 180	39	34	975	CP/CS/CT/CZ
• 641	2	300	100 x 100	50	44	975	CP/CS/CT/CZ
• 642	2	300	100 x 100	50	44	975	CP/CS/CT/CZ
• 642	2	300	100 x 100	39	34	975	CP/CS/CT/CZ
• 644	2	300	100 x 100	50	44	975	CP/CS/CT/CZ
• 644	2	300	100 x 100	39	34	975	CP/CS/CT/CZ
• 646	2	300	100 x 100	50	44	975	CP/CS/CT/CZ
• 646	2	300	100 x 100	39	34	975	CP/CS/CT/CZ
• 648	2	300	100 x 100	50	44	975	CP/CS/CT/CZ
• 648	2	300	100 x 100	39	34	975	CP/CS/CT/CZ

CP/CS/CT/CZ

• Can be equipped with flush valve

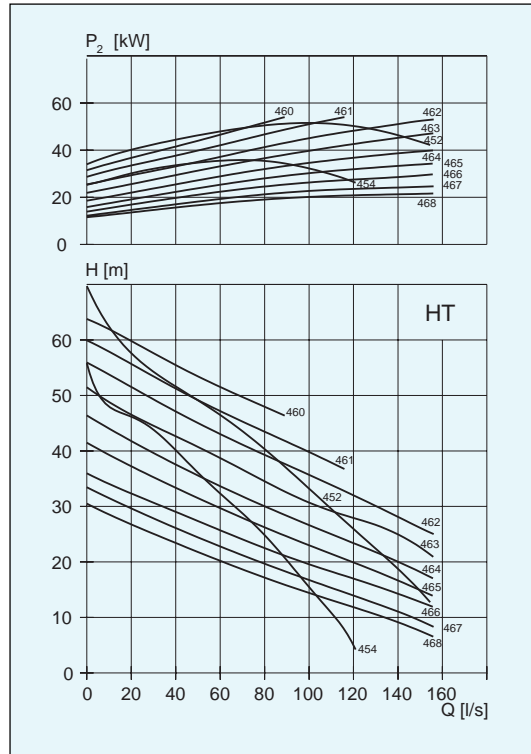

Impeller code	No. of vanes	Outlet dia mm CP vers.	Through-let, mm	Motor rating kW		rpm	Available versions
				P ₁	P ₂		
• 452	1	200	90 x 96	60	54	1475	CP/CS/CT/CZ
• 454	1	200	76 x 90	60	54	1475	CP/CS/CT/CZ
• 454	1	200	76 x 90	45	40	1475	CP/CS/CT/CZ
• 460-463	2	200	76 x 76	60	54	1475	CP/CS/CT/CZ
• 464-468	2	200	76 x 76	60	54	1475	CP/CS/CT/CZ
• 464-468	2	200	76 x 76	45	40	1475	CP/CS/CT/CZ

C- AND R-PUMPS • 50 Hz

LARGE SIZE

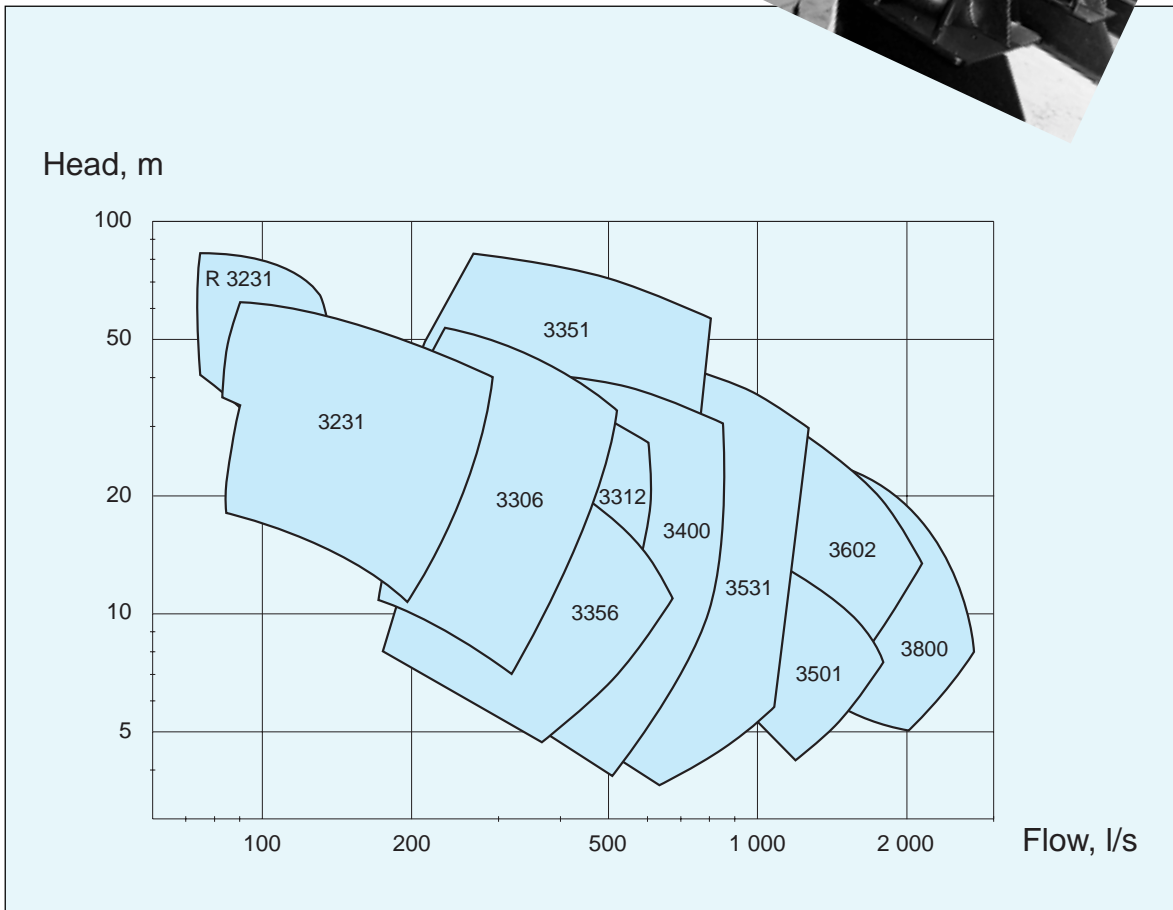
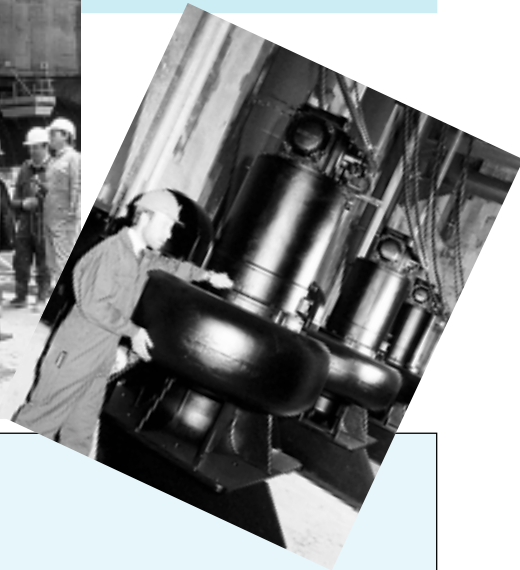

The C-pumps are equipped with shrouded multi-channel impellers running in a volute. The shape and the size of the channel minimize clogging, and therefore make the pump ideal for waste water containing large solid particles.



CP/CS/CT/CZ

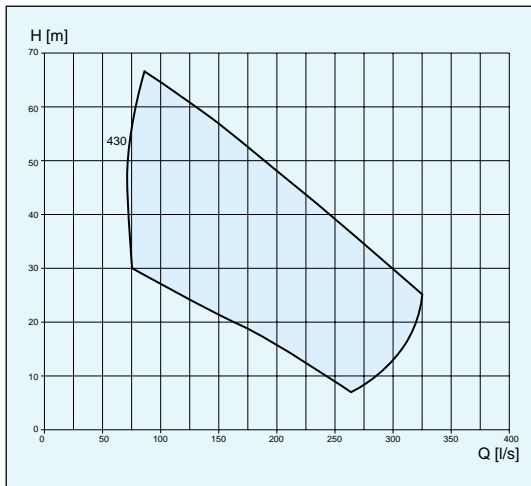

Impeller code	No. of vanes	Outlet dia mm CP vers.	Through-let, mm	Motor rating kW		rpm	Available versions
				P ₁	P ₂		
430	2	200	∅ 88	76-181	70-170	1485	CP/CS/CT/CZ

3231

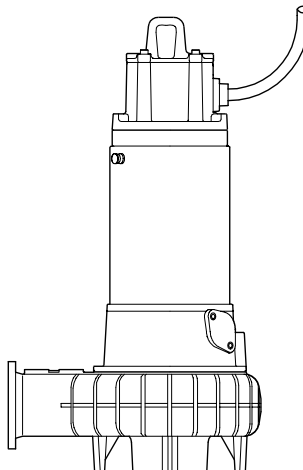

	CP	CS	CT	CZ
Max weight, kg	1820	1910	1730	1730

CP/CS/CT/CZ

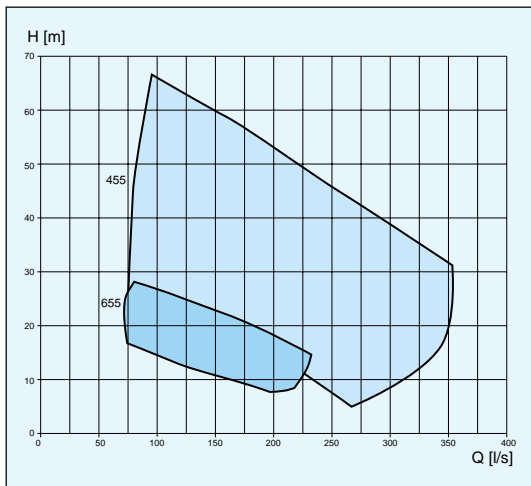

Impeller code	No. of vanes	Outlet dia mm CP vers.	Through-let, mm	Motor rating kW		rpm	Available versions
				P ₁	P ₂		
455	2	200	∅ 102	76-181	70-170	1485	CP/CS/CT/CZ
655	2	200	∅ 102	64	58	985	CP/CS/CT/CZ

RP/RT

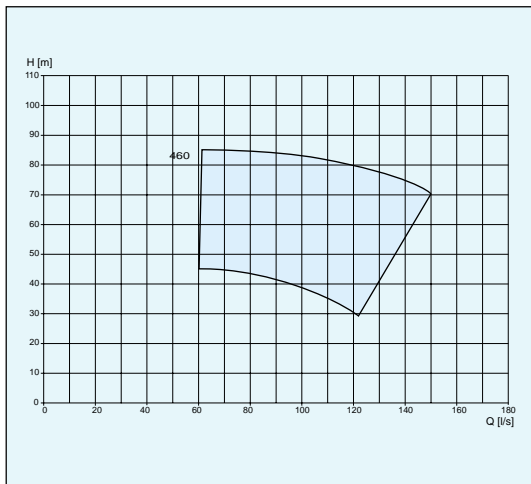

Impeller code	No. of vanes	Outlet dia mm RP vers.	Through-let, mm	Motor rating kW		rpm	Available versions
				P ₁	P ₂		
460	6	150	∅ 24	76-181	70-170	1485	RP/RT

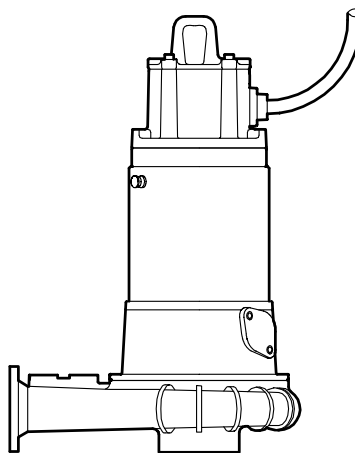

	RP	RT
Max weight, kg	1650	1620

RP/RT

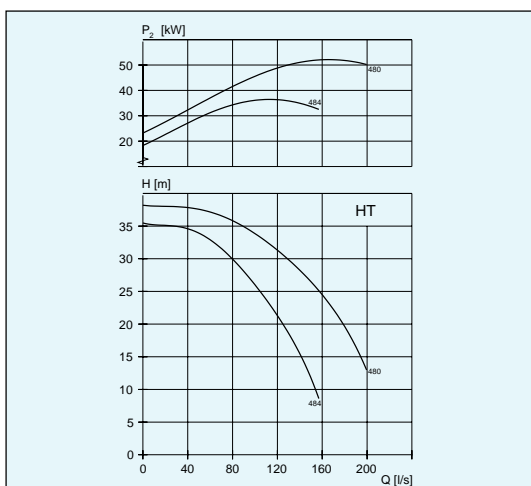

Impeller code	No. of vanes	Outlet dia mm	Through-let, mm	Motor rating kW		rpm	Available versions
				P ₁	P ₂		
480	6	150	37 x 37	45	40	1475	RP/RT
484	6	150	32 x 32	60	54	1475	RP/RT

R 3300

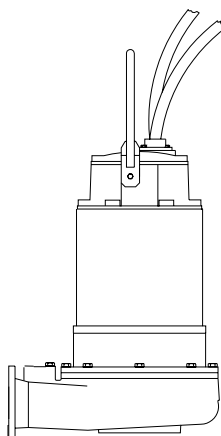

	RP	RT
Max weight, kg	820	943

CP/CS/CT/CZ

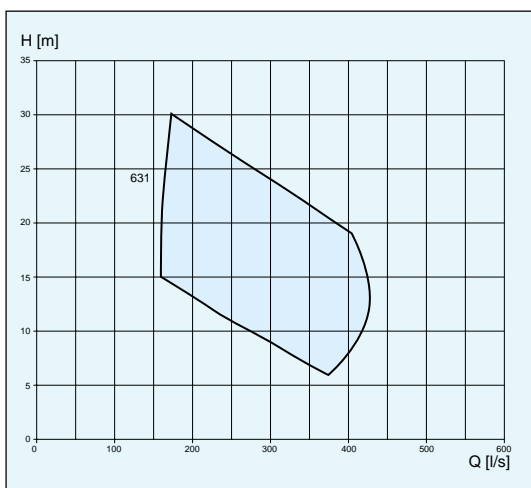

Impeller code	No. of vanes	Outlet dia mm CP vers.	Through-let, mm	Motor rating kW		rpm	Available versions
				P ₁	P ₂		
631	3	300	∅ 104	64-150	58-140	985	CP/CSCT/CZ

3306

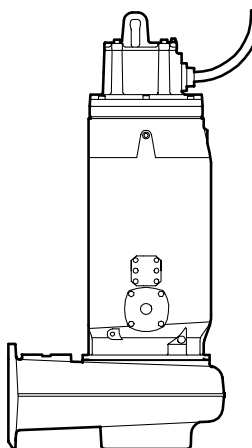

	CP	CS	CT	CZ
Max weight, kg	1920	2005	1820	1820

CP/CS/CT/CZ

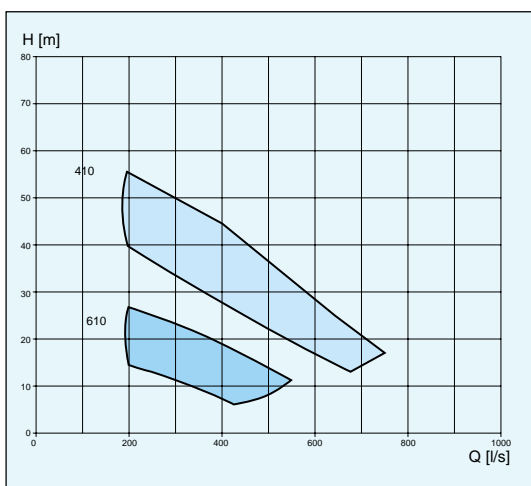

Impeller code	No. of vanes	Outlet dia mm CP vers.	Through-let, mm	Motor rating kW		rpm	Available versions
				P ₁	P ₂		
410	3	300	∅ 104	181-228	170-215	1480	CP/CSCT/CZ
610	3	300	∅ 104	64-150	58-140	985	CP/CSCT/CZ

CP/CS/CT/CZ

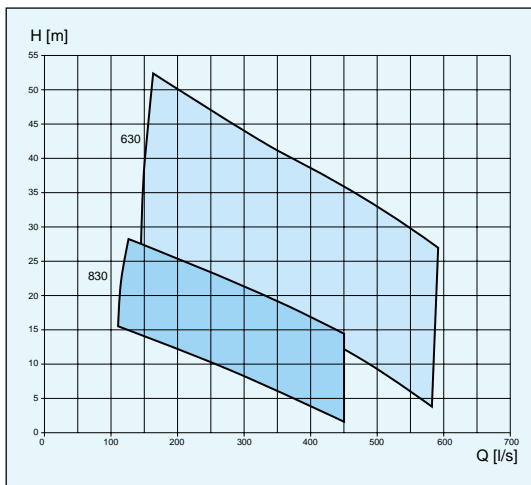

Impeller code	No. of vanes	Outlet dia mm CP vers.	Through-let, mm	Motor rating kW		rpm	Available versions
				P ₁	P ₂		
630	3	300	∅ 102	109-265	100-250	990	CP/CS/CT/CZ
830	3	300	∅ 102	61-100	55-90	735	CP/CS/CT/CZ

3312

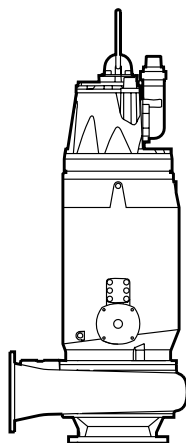

	CP	CS	CT	CZ
Max weight, kg	3150	3325	3050	3050

CP/CT/CZ

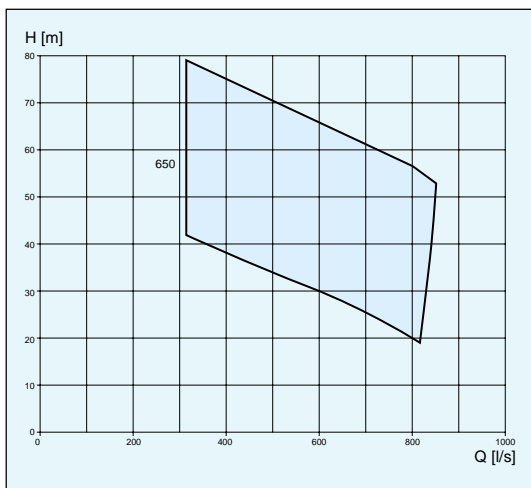

Impeller code	No. of vanes	Outlet dia mm CP vers.	Through-let, mm	Motor rating kW		rpm	Available versions
				P ₁	P ₂		
650	2	350	∅ 110	305-583	290-560	995	CP/CT/CZ

3351

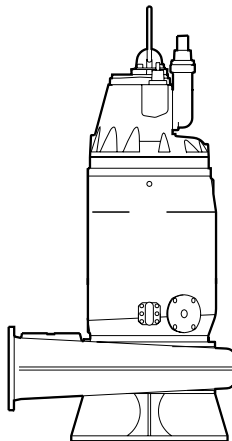

	CP	CT	CZ
Max weight, kg	5500	5520	5250

CP/CT/CZ

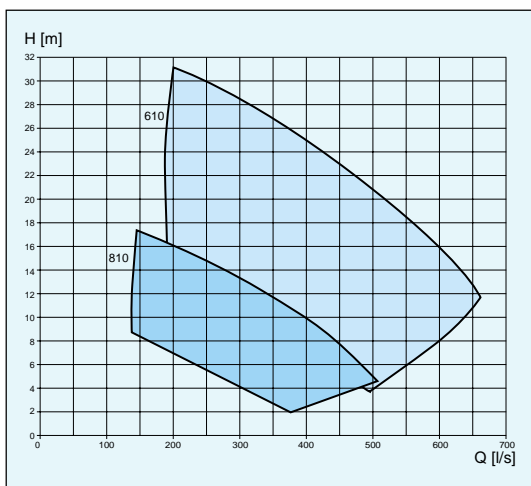

Impeller code	No. of vanes	Outlet dia mm CP vers.	Through-let, mm	Motor rating kW		rpm	Available versions
				P ₁	P ₂		
610	3	350	∅ 102	64-150	58-140	990	CP/CT/CZ
810	3	350	∅ 102	51-61	45-55	735	CP/CT/CZ

3356

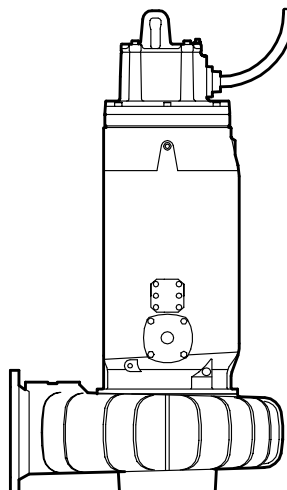

	CP	CT	CZ
Max weight, kg	2050	1950	1950

CP/CT/CZ

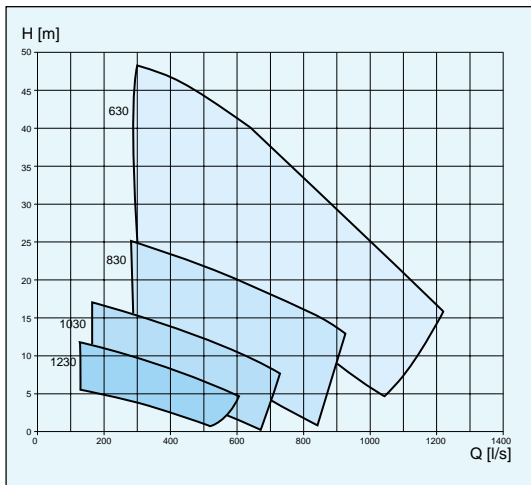

Impeller code	No. of vanes	Outlet dia mm CP vers.	Through-let, mm	Motor rating kW		rpm	Available versions
				P ₁	P ₂		
630	3	400	110	191-327	180-310	990	CP/CT/CZ
830	3	400	110	100-172	90-160	735	CP/CT/CZ
1030	3	400	110	44-99	40-90	585	CP/CT/CZ
1230	3	400	110	34-45	30-40	490	CP/CT/CZ

3400

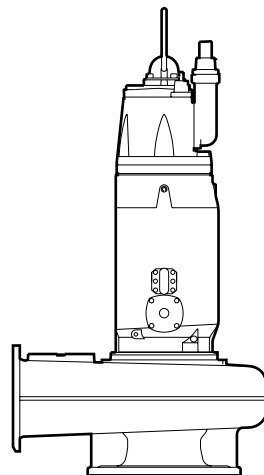

	CP	CT	CZ
Max weight, kg	3850	3700	3700

CP/CT/CZ

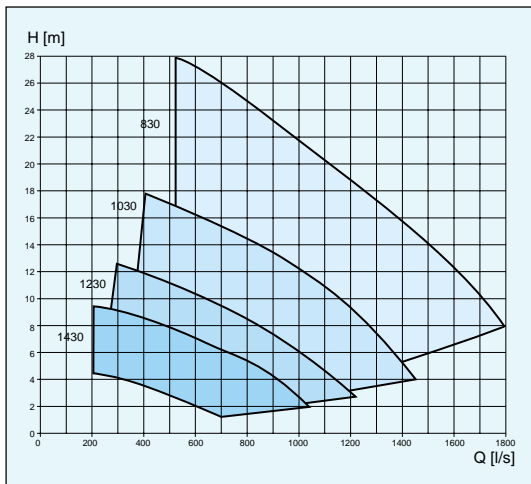

Impeller code	No. of vanes	Outlet dia mm CP vers.	Through-let, mm	Motor rating kW		rpm	Available versions
				P ₁	P ₂		
830	3	500	∅ 110	164-293	150-275	740	CP/CT/CZ
1030	3	500	∅ 110	99-183	90-170	590	CP/CT/CZ
1230	3	500	∅ 110	45-109	40-100	490	CP/CT/CZ
1430	3	500	∅ 110	46-68	40-60	420	CP/CT/CZ

3501

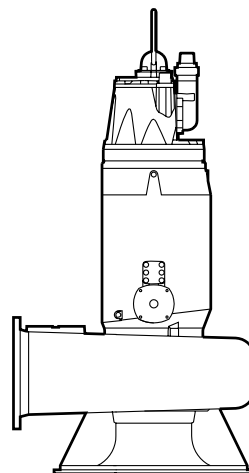

	CP	CT	CZ
Max weight, kg	4330	4100	4100

CP/CT/CZ

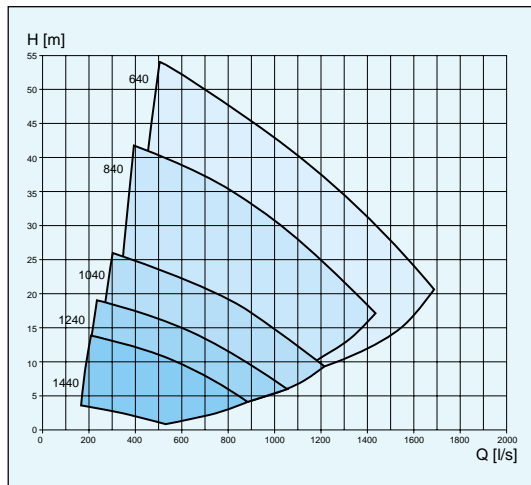

Impeller code	No. of vanes	Outlet dia mm CP vers.	Through-let, mm	Motor rating kW		rpm	Available versions
				P ₁	P ₂		
640	3	500	∅ 105	265-583	250-560	995	CP/CT/CZ
840	3	500	∅ 105	137-417	125-400	745	CP/CT/CZ
1040	3	500	∅ 105	67-231	60-215	590	CP/CT/CZ
1240	3	500	∅ 105	45-152	40-140	495	CP/CT/CZ
1440	3	500	∅ 105	46-79	40-70	420	CP/CT/CZ

3531

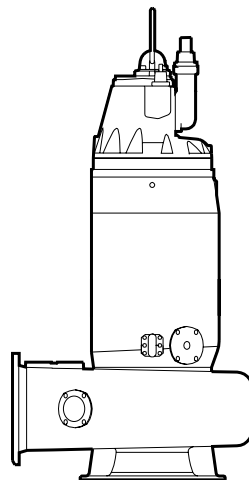

	CP	CT	CZ
Max weight, kg	5500	5300	5300

CP/CT/CZ

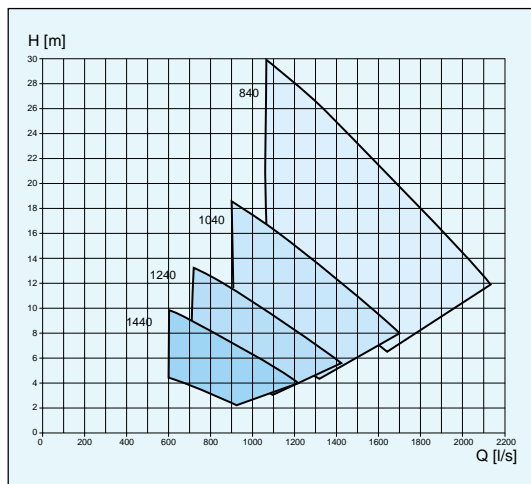

Impeller code	No. of vanes	Outlet dia mm CP vers.	Through-let, mm	Motor rating kW		rpm	Available versions
				P ₁	P ₂		
840	4	600	∅ 126	230-479	215-460	745	CP/CT/CZ
1040	4	600	∅ 126	121-264	110-250	595	CP/CT/CZ
1240	4	600	∅ 126	67-152	60-140	495	CP/CT/CZ
1440	4	600	∅ 126	68-88	60-80	420	CP/CT/CZ

3602

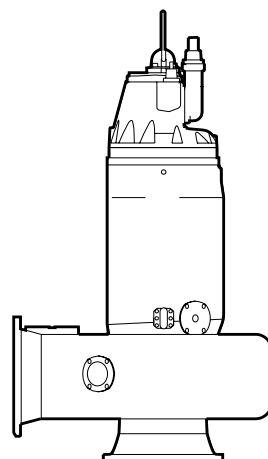

	CP	CT	CZ
Max weight, kg	6200	5950	5950

CP/CT/CZ

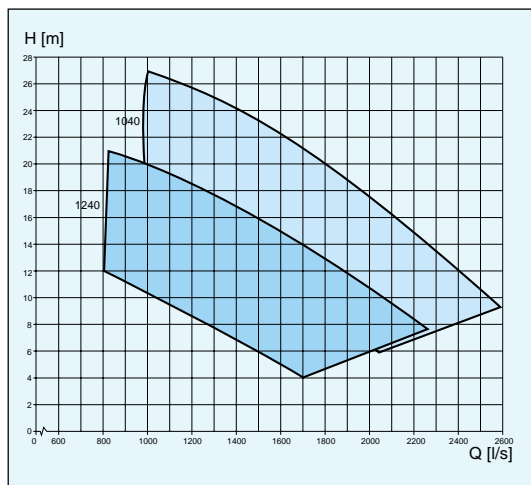

Impeller code	No. of vanes	Outlet dia mm CP vers.	Through-let, mm	Motor rating kW		rpm	Available versions
				P ₁	P ₂		
1040	4	800	∅ 140	342-473	325-450	595	CP/CT/CZ
1240	4	800	∅ 140	241-345	225-325	495	CP/CT/CZ

3800

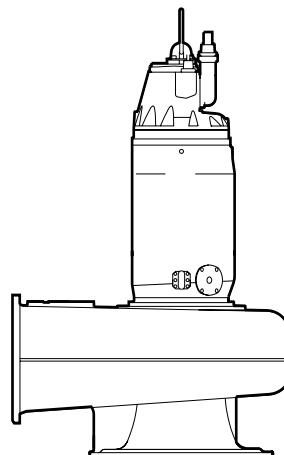

	CP	CT	CZ
Max weight, kg	9000	8600	8600