

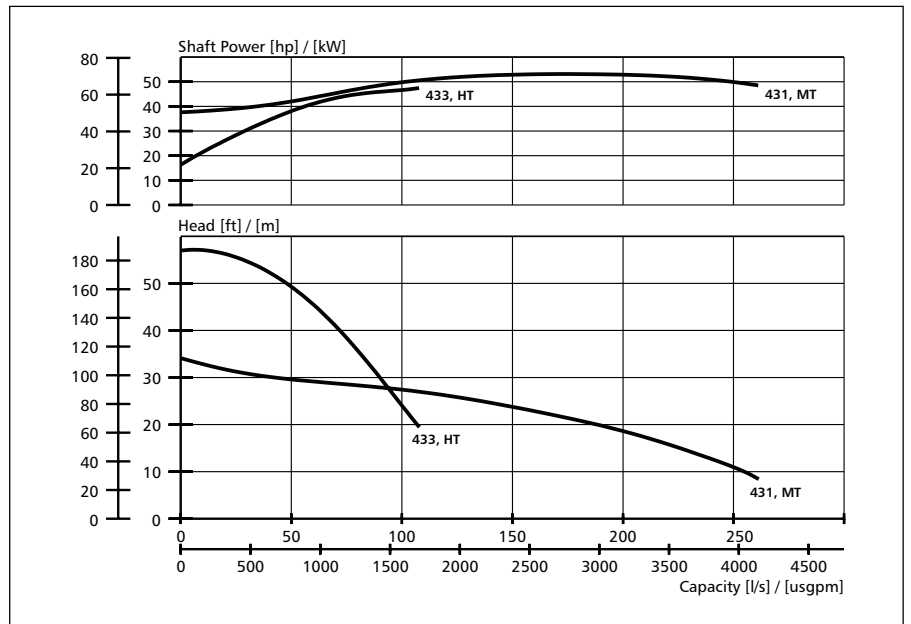

Technical specification BIBO 2250.011

50 Hz

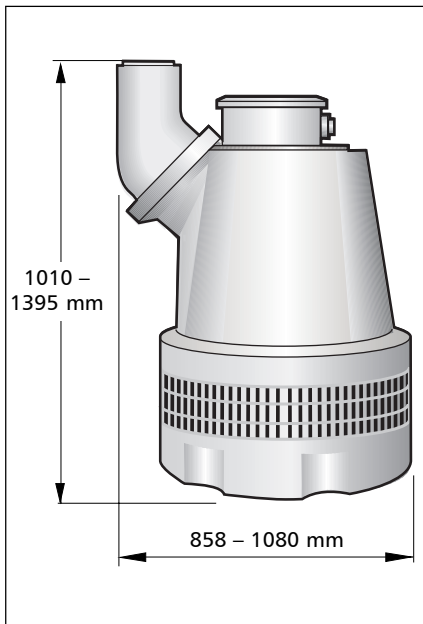

Product

Submersible pump for dewatering building yards, draining water in flooded areas, and other similar applications. The pump can handle water containing relatively abrasive solids.

Denomination

Product code _____ 2250.011
 Installation _____ S
 Impeller characteristic _____ MT, HT
 Discharge connection _____ 6", 8", 10"

Process data

Liquid temp. _____ max +40° C
 Depth of immersion _____ max 20 m
 The pH of the pumped liquid ___ pH 5 - 8
 Liquid density _____ max 1100 kg/m³
 Strainer hole size _____ 15 mm x 45 mm

Motor data

Squirrel cage 3-phase induction motor.
 Frequency _____ 50 Hz
 Insulation class _____ H (+180° C)
 Voltage variation
 - continuously running _____ max ± 5%
 - intermittent running _____ max ± 10%
 Voltage imbalance between phases max 2%
 No. of starts/hour _____ max 15

Cable

Direct-on-line and Y/D start _____ SUBCAB

Monitoring equipment

Thermal contacts.

Material

Outer casing _____ Aluminium
 Impeller _____ Alloyed white cast iron
 Wear parts _____ Nitrile rubber
 Stator housing _____ Aluminium
 Strainer _____ Steel
 Shaft _____ Stainless steel
 O-rings _____ Nitrile rubber

Mechanical face seals

Inner Corrosion resistant cemented carbide
 Outer Corrosion resistant cemented carbide

Weight

Total (excl. cable) _____ 540 kg

Options

Polyurethane-lined wear parts _ POLY-LIFE
 Discharge connector with coupling 6"
 Various cable sizes
 Zinc anodes
 Tandem connection

Accessories

Adapters, hose connections and other mechanical accessories.
 Electrical accessories such as pump controller, control panels, starters, monitoring relays, cables.

Rating

3~
 Rated output _____ 54 kW
 Speed of rotation _____ 1470 rpm

Voltage V	Rated current A	Starting current A
200D	203	1175
220D	181	930
380Y	105	535
440D	91	505
550D	74	425