



BIBO BS-2151.050(P)

Submersible Pump

Large Permissible Mine Dewatering Pump

Capacity up to 1500 GPM, heads up to 240 ft.



Specifications

- A **Cable.** Standard 50 ft. of AWG 6/3-2-1-GC SubCab cable. Other lengths available.
 - B **Junction Chamber.** Cable entry incorporates a strain relief and grommet controlled compression sealing. Between the junction box and stator housing the terminal board provides additional seal protection of the motor.
 - C **Pump Housing.** High strength, lightweight aluminum alloy. Static seals are leakproof Nitrile rubber O rings in precision machined grooves, with controlled compression.
 - D **Shaft.** Stainless steel ANSI 420.
 - E **Motor.** Air filled, NEMA design B with class F (155°C) insulation; 2 pole, 3500 rpm. Shrink-fit to the motor housing. Allows at least 10 starts per hour. Built-in thermal sensors for additional motor overload protection.
 - F **Bearings.** Upper: single row ball bearing. Lower: double row angular contact ball bearing.
 - G **Shaft Seals.** Independent double face seals running in environmentally friendly, FDA approved (Standard #172.878) lubricant. Upper seal: tungsten carbide/carbon. Lower seal: tungsten carbide/tungsten carbide. Oil quantity: 2.5 pints (1.2 l).
 - H **Impeller.** Multivane, open type. Material: high chrome alloyed cast iron ASTM 532.80 Alloy IIIA, hardened for high wear resistance to 60 Rc hardness.
 - I **Diffuser.** Protected by Nitrile Rubber liner. Adjustable to maintain pump's hydraulic performance.
 - J **Wear Plate.** Protected by Nitrile Rubber liner.
 - K **Strainer.** Hot dip galvanized steel. 261 holes 3/8" x 1-5/8". Spring loaded to absorb heavy impact.
- Fasteners.** Stainless steel ANSI 304.

Options.

Stainless steel impellers;

Approval:

MSHA pump certification: X/P-3756-0

MSHA system approval: 2G-3827A-0

Controls (not shown).

MSHA certified controls, manual and automatic (intrinsically safe), for unattended operation (not available for 950 V).

Accessories.

Tandem connection; Zinc anodes.

Applications:

The BS-2151(P), a robust, large capacity pump, is ready for demanding duties in the most diverse environments.

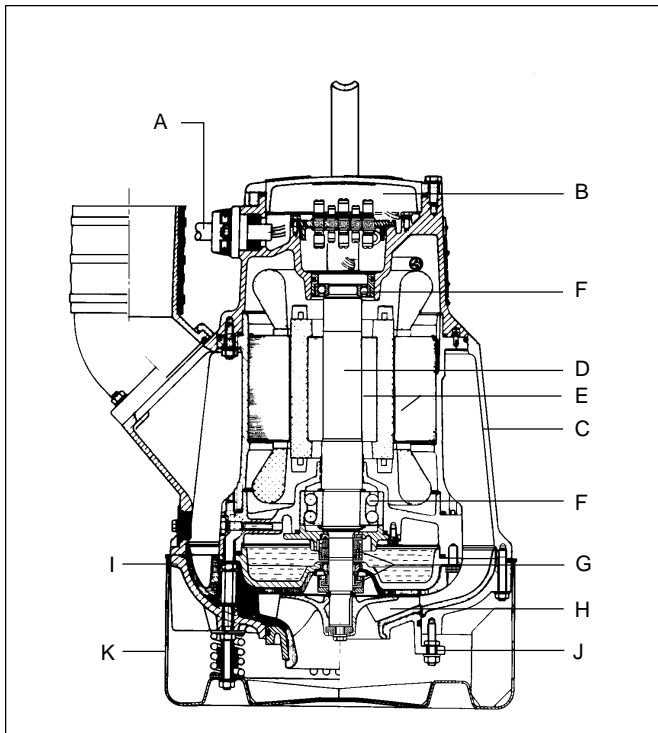

BIBO BS-2151.050(P)

Power Input and Performance Data

Power Input kW

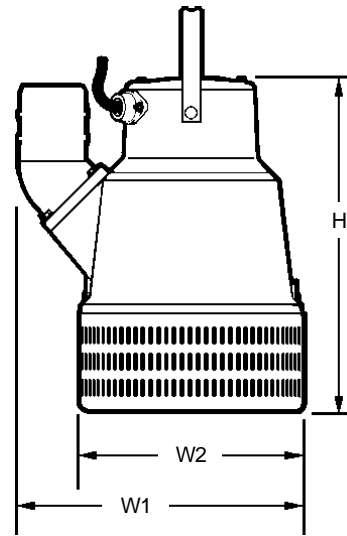
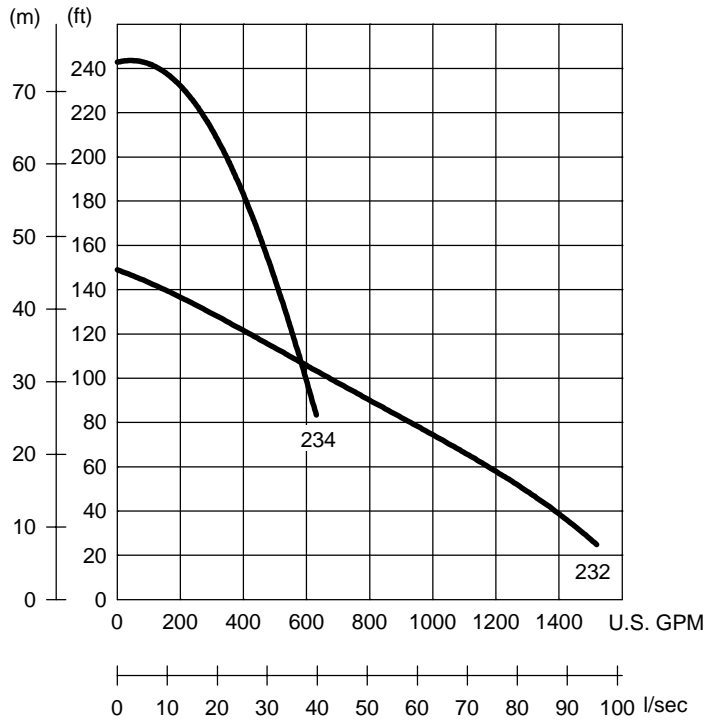
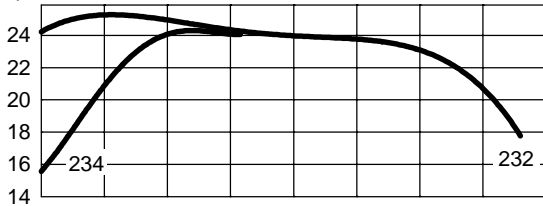

Dimensions

Discharge conn.	W1 inches	W1 mm	W2 inches	W2 mm	H inches	H mm	Weight lbs.	Weight kg	Tandem conn.*
-----------------	-----------	-------	-----------	-------	----------	------	-------------	-----------	---------------

4" High Head

4"-8 NPSM (Male)	23	585	19 7/8	505	30 1/8	765	359	163	4" NPSM (Male)
------------------	----	-----	--------	-----	--------	-----	-----	-----	----------------

6" High Volume

6"-8 NPSM (Female)	25 3/4	655	19 7/8	505	30 1/8	765	364	165	6" NPSM (Female)
--------------------	--------	-----	--------	-----	--------	-----	-----	-----	------------------

*Optional

VERSION	IMP. CODE	HP	PHASE	VOLTS	FLA	LRA	PUMP CABLE SIZE AWG	TRAILING CABLE SIZE AWG	MAX.* COMBINED CABLE LENGTH (FT.)
High Head HT 4"	234	30	3	460	34	256	6/3-2-1-GC	6/5	730
			3	575	27	165			1,225
			3	950	16	100	6/3-G-GC	N/A	N/A
Standard MT 6"	232	30	3	460	34	256	6/3-2-1-GC	6/5	730
			3	575	27	165			1,225
			3	950	16	100	6/3-G-GC	N/A	N/A

* THE MAXIMUM LENGTH OF AWG # 6/5 TRAILING CABLE IS 500 FT.

** SPECIAL P122 MSHA, 2,000 V CABLE (NOT BY FLYGT)

SALES • SERVICE • RENTALS

Coquitlam, B.C., Tel.: (604) 941-6664, Fax: (604) 941-3659 • Calgary, Alta., Tel.: (403) 279-8371, Fax: (403) 279-0948 • Edmonton, Alta., Tel.: (780) 489-1961, Fax: (780) 486-5530
 Saskatoon, Sask., Tel.: (306) 933-4849, Fax: (306) 931-0051 • Winnipeg, Mb., Tel.: (204) 235-0050, Fax: (204) 235-0066 • Etobicoke, On., Tel.: (416) 675-3630, Fax: (416) 675-3636
 Nepean, On., Tel.: (613) 225-9600, Fax: (613) 225-5496 • Sudbury, On., Tel.: (705) 560-2141, Fax: (705) 560-8260 • Timmins, On., Tel.: (705) 360-1852, Fax: (705) 360-1855
 Thunder Bay, On., Tel.: (807) 625-9960, Fax: (807) 625-9970 • Pointe-Claire, Qc., Tel.: (514) 695-0100, Fax: (514) 695-7990 • Beauport, Qc., Tel.: (418) 667-1694, Fax: (418) 666-9593
 Val d'Or, Qc., Tel.: (819) 825-0792, Fax: (819) 825-5677 • Moncton, N.B., Tel.: (506) 857-2244, Fax: (506) 859-8612 • Halifax, N.S., Tel.: (902) 450-1177, Fax: (902) 450-1170
 St. John's, Nfld., Tel.: (709) 722-6717, Fax: (709) 722-9832



ITT Industries