

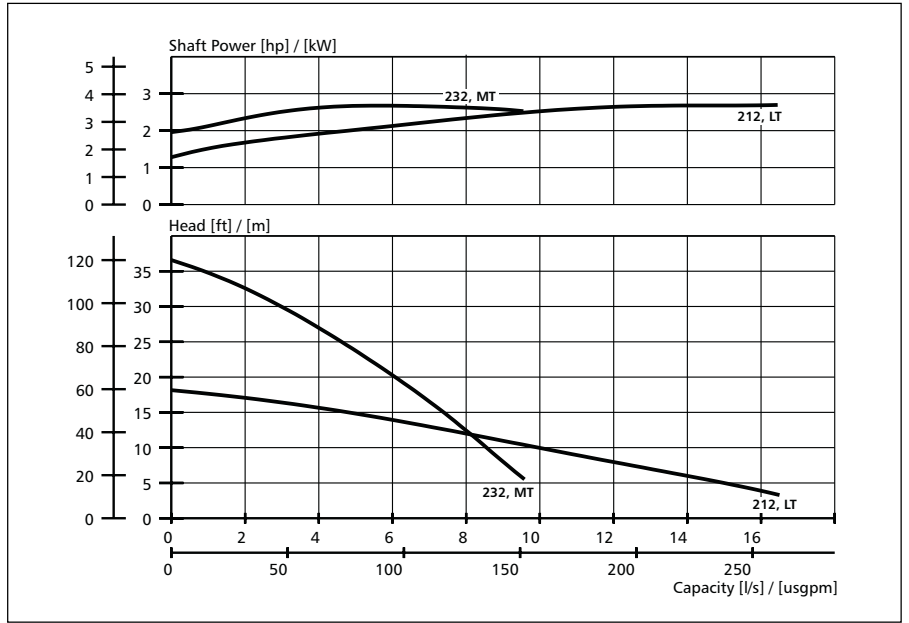

Technical specification BIBO 2071.010

50 Hz

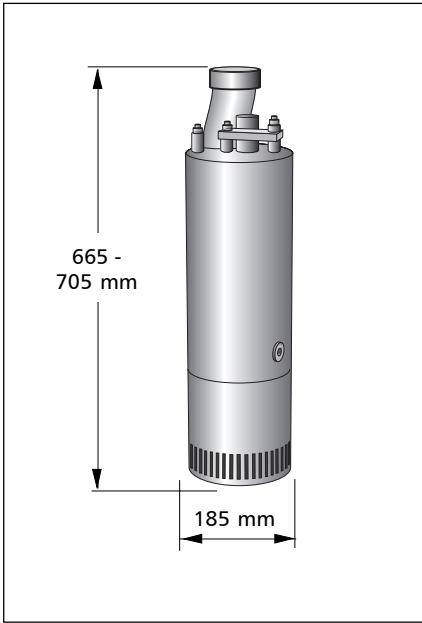

Product

Submersible pump for dewatering building yards, draining water in flooded areas, and other similar applications. The pump can handle water containing relatively abrasive solids.

Denomination

Product code _____ 2071.010
 Installation _____ S
 Impeller characteristic _____ LT, MT
 Discharge connection _____ 1½", 2", 3"

Process data

Liquid temperature _____ max +40° C
 Depth of immersion _____ max 20 m
 pH of the pumped liquid _____ pH 5 - 8
 Liquid density _____ max 1100 kg/m³
 Strainer hole size _____ 8 mm x 50 mm

Motor data

Squirrel cage 3-phase induction motor.
 Frequency _____ 50 Hz
 Insulation class _____ H (+180° C)
 Voltage variation
 - continuously running _____ max ± 5%
 - intermittent running _____ max ± 10%
 Voltage imbalance between phases max 2%
 No. of starts/hour _____ max 15

Cable

Direct-on-line start _____ SUBCAB

Monitoring equipment

Thermal contacts.

Material

Outer casing _____ Aluminium
 Impeller, alt.1 _____ Spring steel
 alt.2 _____ Stainless steel
 Wear parts _____ Nitrile rubber
 Stator housing _____ Aluminium
 Strainer _____ Galvanized steel
 Shaft _____ Stainless steel
 O-rings _____ Nitrile rubber

Mechanical face seals

Inner Corrosion resistant cemented carbide
 Outer Corrosion resistant cemented carbide

Weight

Total (excl. cable) _____ 28 - 31 kg

Options

Polyurethane-lined wear parts POLY-LIFE®
 Impeller _____ Stainless steel
 Discharge connections with coupling B with adapter
 Starters
 Warm liquid
 Various cable sizes
 Zinc anodes
 Tandem connection

Accessories

Adapters, hose connections and other mechanical accessories.
 Electrical accessories such as pump controller, control panels, starters, monitoring relays, cables.

Rating

3~
 Rated output _____ 3.0 kW
 Speed of rotation _____ 2800 rpm

Voltage V	Rated current A	Starting current A
220	11.0	60.1
380	6.6	34.6
400	6.3	30.0
415	6.0	31.0
440	5.7	32.9
500	5.0	24.7
550	4.6	27.1
660	3.8	20.0