



Flygt Submersible Pumps

AVAILABLE FOR RENTAL AND SALE



www.motralec.com / service-commercial@motralec.com / 01.39.97.65.10

Flygt 5000 Series

A chain is only as strong as its weakest link. That's why we pay attention to the details: it's only by eliminating all the weak links that we can supply pumps our customers really can rely on. Pumps that give them greater peace of mind.

The main difference between slurry and waste water pumps is in the parts that are in direct contact with the slurry and thus subject to wear by the slurry's solid particles.

Better heat transfer

Our specially designed and manufactured motor provides enhanced cooling because heat losses are concentrated around the stator. Trickle impregnated in resin (Class H insulation), the stator windings are rated at 180°C (355°F) and enable up to 30 starts per hour.

Efficient cooling

These pumps are cooled either by the surrounding liquid or, in more demanding applications, with an internal closed-loop cooling system.

Inspection chamber

To increase operational reliability, an inspection chamber between the seal unit and the bearings enables rapid spot checks and maintenance. In the case of a seal failure, a built-in sensor provides an early warning of any fluid build-up, thus reducing the risk of expensive repair work.

Agitator

The pump can be equipped with an agitator. The unique design of Flygt agitators create a strong vertical thrust, which forces settled solids into suspension. This makes the particles easier to transport and ensures a cleaner sump at the end of the pumping cycle. When pumping coarse slurries, an agitator mounted on the pump shaft resuspends settled particles and makes them possible to transport.

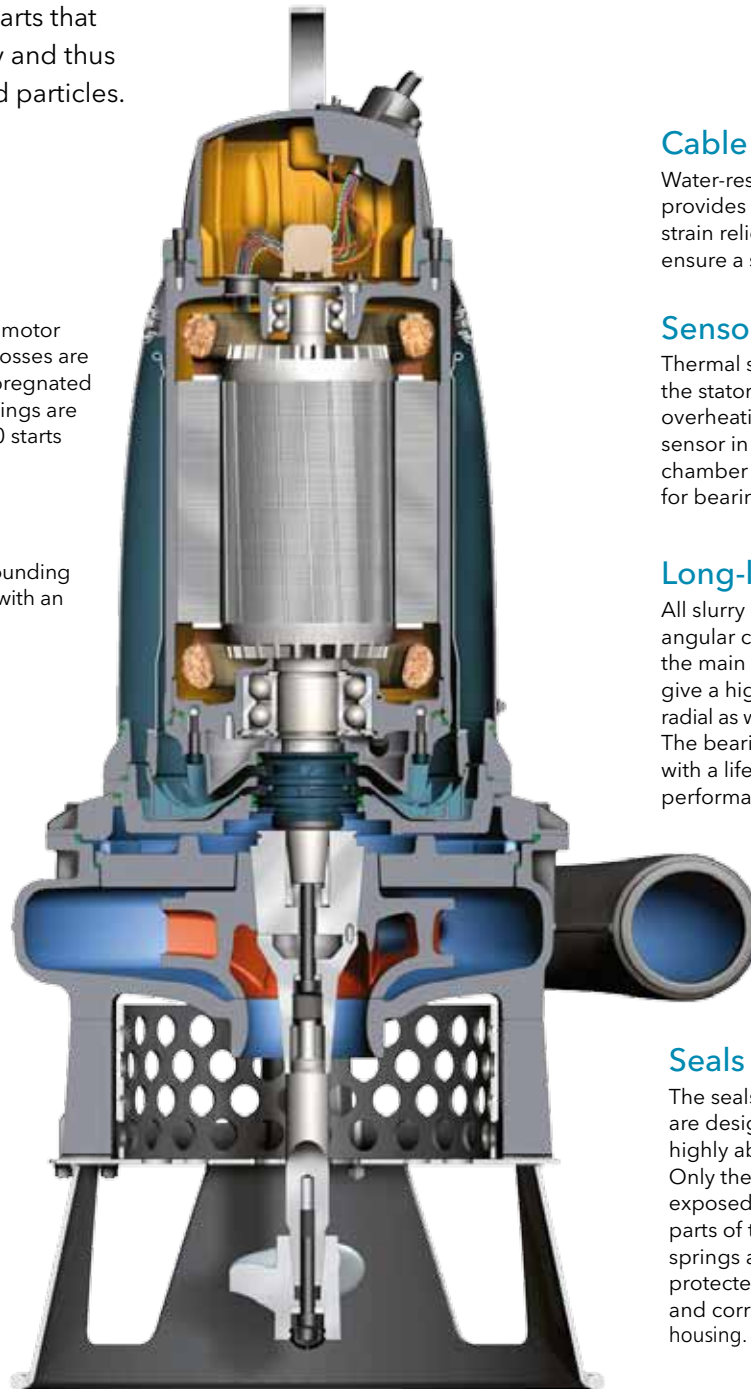

Cable entry

Water-resistant cable entry provides both sealing and strain relief functions to ensure a safe installation.

Sensors

Thermal sensors embedded in the stator windings prevent overheating, and a leakage sensor in the inspection chamber minimizes the risk for bearing and stator failure.

Long-life bearings

All slurry pumps have two row angular contact ball bearings as the main bearing, because they give a high load capability in the radial as well as the axial direction. The bearings are well protected with a lifetime lubrication of high performance grease.

Seals

The seals for the slurry pumps are designed to cope with highly abrasive pump media. Only the seal rings are exposed to the media. Other parts of the seal, such as springs and torque locks are protected from wear, clogging and corrosion inside the seal housing.

Flygt 5150-series submersible pump equipped with agitator

5000 Series Heavy-Duty Slurry Pumps

HS 5100/5500 series pumps will easily handle extremely abrasive slurries containing sand, gravel, grit or ash, without damage. Both the impeller and pump casing are made of high chrome alloyed cast iron, for maximum abrasion resistance. The HS 5100 series pumps use a one-piece pump casing, while the HS 5500 series have a replaceable liner of high chrome alloyed cast iron. Heavy-duty mechanical seals are protected by a unique expeller and pressure isolation chamber. The optional agitator, when attached to the shaft, resuspends particles around the pump inlet.

HS 5100.211

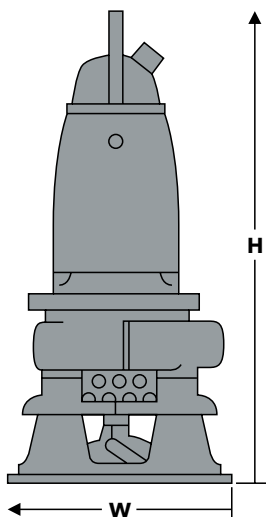

Model number: 5100.211
 Motor rating: 15 HP@1150 RPM
 20 HP@1755 RPM
 Voltage (3 ϕ): 230V
 Full load amps: 46/52A
 460V 575V
 22/26A 17/21A
 Versions: 4" Std., Imp.
 4" High vol., Imp.
 Discharge conn: 4" Victaulic
 Pump dimensions: 23 1/2" W (max.),
 45 1/4" H (max.)
 Max. weight (lbs.): 555
 Description: Cast iron construction with high
 chrome volute; high chrome
 multi-vane closed impeller; rests
 on stand.
 Options: Agitator;
 Explosion proof (FM approved)
 variant 5100.221

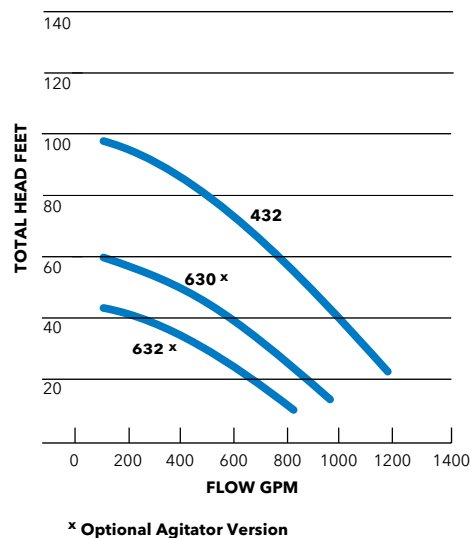

HS 5100.251

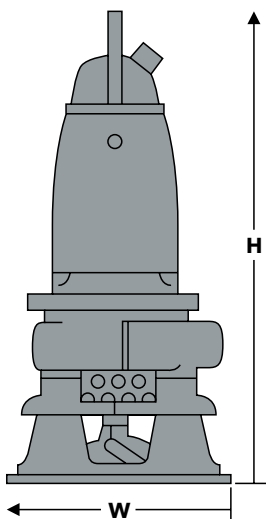

Model number: 5100.251
 Motor rating: 25 HP@1160 RPM
 34 HP@1760 RPM
 Voltage (3 ϕ): 230V
 Full load amps: 64/81A
 460V 575V
 32/40A 25/32A
 Versions: 4" Std., Imp.
 4" High vol., Imp.
 Discharge conn: 4" Victaulic
 Pump dimensions: 23 1/2" W (max.),
 50 1/4" H (max.)
 Max. weight (lbs.): 710
 Description: Cast iron construction with high
 chrome volute; high chrome
 multi-vane closed impeller; rests
 on stand.
 Options: Agitator;
 Explosion proof (FM approved)
 variant 5100.261

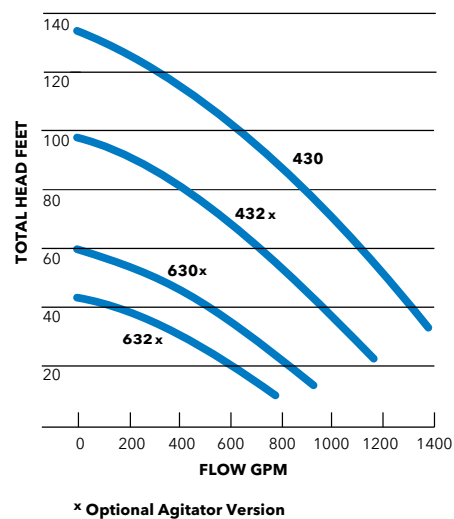

HS 5100.300

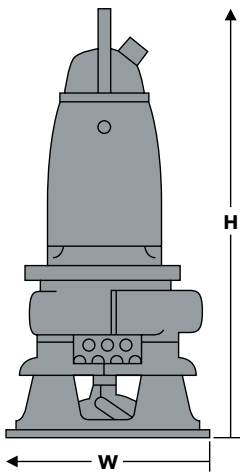

Model number: 5100.300
 Motor rating: 45HP@1170 RPM
 70HP@1775 RPM
 Voltage (3Ø): 460V 575V
 Full load amps: 55/72/80A 44/58/63A
 Versions: 4" Standard
 Imp. Code 430, 432
 4" High volume
 Imp. Code 630, 632
 Discharge conn: 4" Victaulic
 Pump dimensions: 23 1/2" W (max.),
 57 3/4" H (max.)
 Max. weight (lbs.): 1095
 Description: Cast iron construction with high
 chrome volute; high chrome
 multi-vane closed impeller; rests
 on stand.
 Options: Agitator;
 Explosion proof (FM approved)
 variant 5100.310

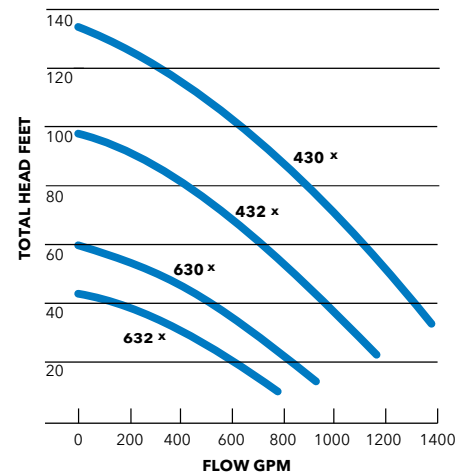

* Optional Agitator Version

HS 5150.300

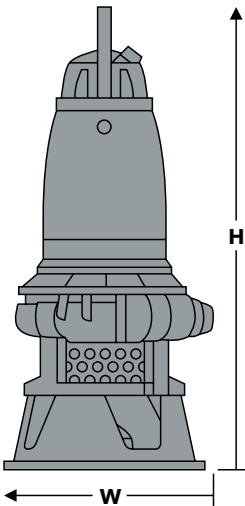

Model number: 5150.300
 Motor rating: 60HP@1775 RPM
 Voltage (3Ø): 460V 575V
 Full load amps: 68/80A 55/63A
 Versions: 6" Standard
 Imp. Code 432, 434
 Discharge conn: 6" Victaulic
 Pump dimensions: 34 1/2" W (max.),
 65 1/4" H (max.)
 Max. weight (lbs.): 1465
 Description: Cast iron construction with high
 chrome volute; high chrome
 multi-vane closed impeller; rests
 on stand.
 Options: Agitator;
 Explosion proof (FM approved)
 variant 5150.310

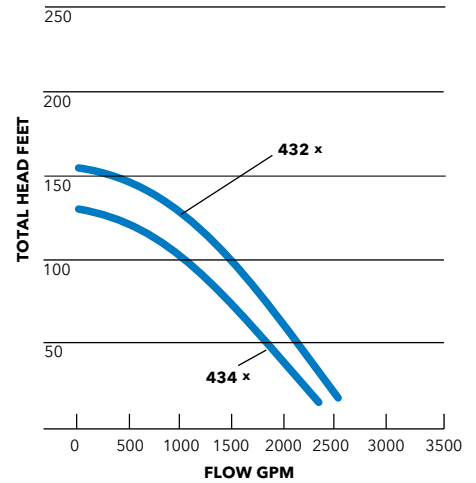

* Optional Agitator Version

HS 5150.350

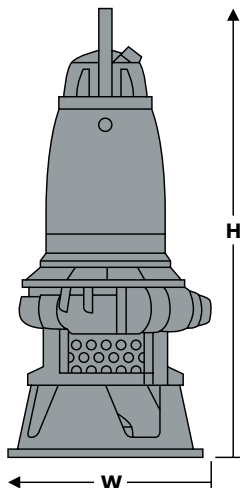

Model number: 5150.350
 Motor rating: 85HP@1775 RPM
 Voltage (3Ø): 460V 575V
 Full load amps: 101/125A 80/101A
 Versions: 6" Standard
 Imp. Code 430, 432, 434,
 436, 438
 Discharge conn: 6" Victaulic
 Pump dimensions: 34 1/2" W (max.),
 70 1/4" H (max.)
 Max. weight (lbs.): 2005
 Description: Cast iron construction with high
 chrome volute; high chrome
 multi-vane closed impeller; rests
 on stand.
 Options: Agitator;
 Explosion proof (FM approved)
 variant 5150.360

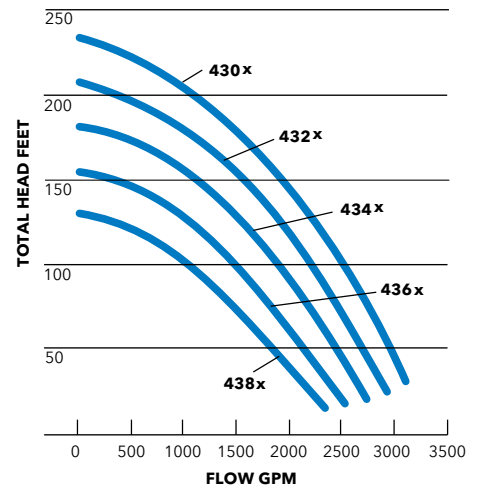

* Optional Agitator Version

HS 5520

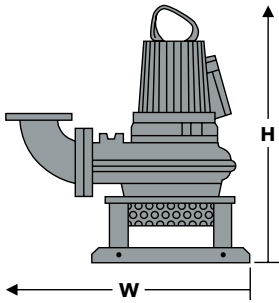

Model number: 5520.180
 Motor rating: 5 HP @ 1735 RPM
 Voltage (3 ϕ): 460V
 Full load amps: 6.6A
 Discharge conn: 4" Flange
 Impeller code: 436
 Pump dimensions: 29 1/2" W (max.),
 33 1/2" H (max.)
 Max. weight (lbs.): 380
 Stator and pump housing material: Cast iron
 Options: FM approved variant;
 Warm liquid version available

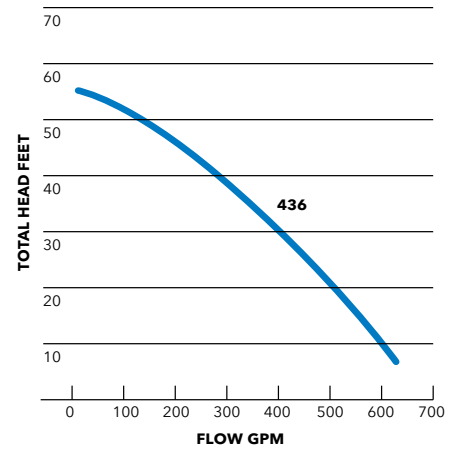

HS 5530

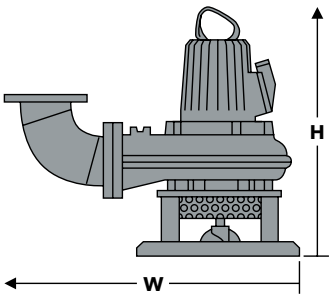

Model number: 5530.180
 Motor rating: 10 HP @ 1740 RPM
 Voltage (3 ϕ): 460V
 Full load amps: 13A
 Discharge conn: 6" Flange
 Impeller code: 436
 Pump dimensions: 42 1/2" W (max.),
 40" H (max.)
 Max. weight (lbs.): 680
 Stator and pump housing material: Cast iron
 Options: Agitator;
 FM approved variant;
 Warm liquid version available

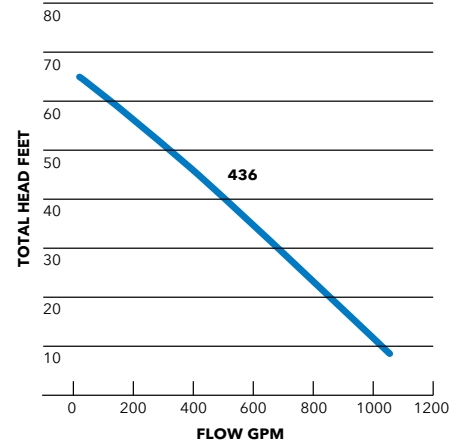

HS 5540

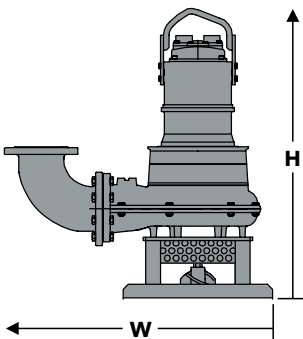

Model number: 5540.181
 Motor rating: 20 HP @ 1750 RPM
 Voltage (3 ϕ): 460V
 Full load amps: 26
 Discharge conn: 6" Flange
 Impeller code: 434
 Pump dimensions: 42 1/2" W (max.),
 46 1/4" H (max.)
 Max. weight (lbs.): 891
 Stator and pump housing material: Cast iron
 Options: Agitator (Imp. Code 435);
 FM approved variant;
 Warm liquid version available

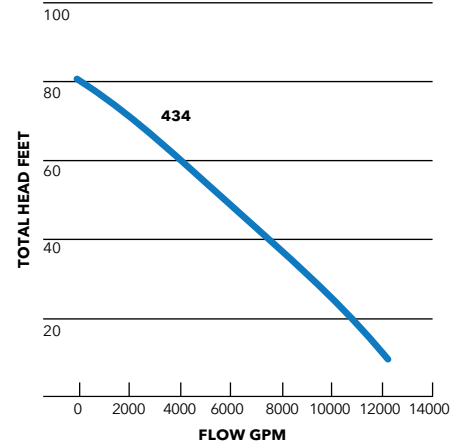

HS 5570

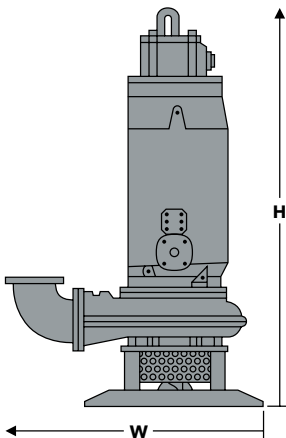

Model number: 5570.180
 Motor rating: 335 HP @ 1760 RPM
 280 HP @ 1185 RPM
 Voltage (3 ϕ): 460V 575V
 Full load amps: 365/345A 300/266A
 Discharge conn: 8" Flange
 Impeller code: 470, 670
 Pump dimensions: 59" W (max.),
 80 1/4" H (max.)
 Max. weight (lbs.): 3230
 Stator and pump housing material: Cast iron
 Options: Agitator;
 FM approved variant;
 Warm liquid version available

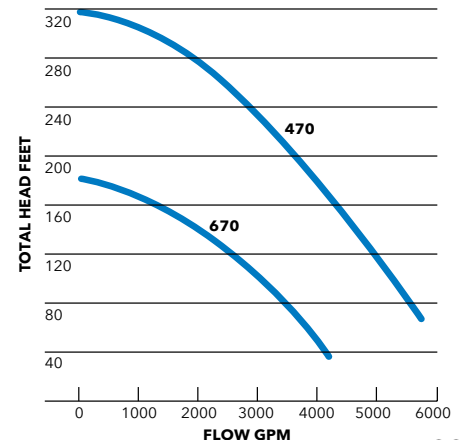

Flygt Accessories

Automatic Level Control Systems



Xylem offers a family of automatic controls that allow unattended operation of Flygt portable pumps. They are available with either two Flygt ENM-10 level sensors or with FPC 100 controller. The FPC 100 allows for automatic pump operation without the use of floats or level sensors.

Manual Control for Medium and Large Portable Pumps



A complete range of manual controls are available for medium and large portable Flygt submersible pumps. Each NEMA 4X enclosure is equipped with the correct circuit breaker/overload for pump protection of the model involved.

Manual Control for Small Portable Pumps



These strong, rugged units provide easy manual control and full electrical protection for smaller Flygt portable submersibles. They include Flygt short-circuit and overload protection, along with starting components for single phase models, housed in a NEMA 4X watertight and corrosion resistant enclosure.

Zinc Anodes



High grade zinc anode kits are available for most Flygt submersible pumps to help protect against the damaging effects of galvanic corrosion. The anodes are easily mounted to the pump with the stainless steel hardware provided. Specify exact pump model when ordering.

Tandem Coupling Kits



Tandem coupling kits are available for most models, allowing the pump to connect in series with another Flygt submersible pump to overcome severe vertical heights. The coupling kit is easily installed after the strainer is removed, allowing the connecting hose from another pump to be attached with clamps. Consult your nearest Flygt location for pressure limitations and other application requirements.

Flygt FPC100 Automatic Pump Controller



The Flygt FPC100 Automatic Pump Controller is used primarily for dewatering pumps in construction and mining applications where ordinary level sensors are not the ideal choice. The FPC 100 offers entirely automatic pump control without the need for components built into the pump or separate level sensor arrangements.

Flygt Pump Flotation Modules



Flygt pump flotation modules (PFM) have been developed to provide a light-weight and cost-effective alternative to traditional steel pontoons. The flotation modules are prefabricated from strong polyethylene with foam filling. The pump floats close to the surface, increasing the pump's service life and reducing maintenance since the pump is no longer working in a high solids environment.

Low Suction Collar



The Flygt low suction collar removes unwanted water down to very low levels when required for emergency services. This works with pump models 2610, 2620 and 2640.