

MIXERS • 50 Hz

4400

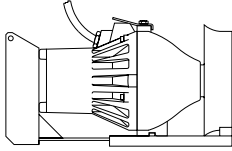

Motor		
Single phase	Max. power, input:	1.8 kW
	Rated power, output:	1.3 kW
	Speed:	1440 RPM
3-phase	Max. power, input:	1.3 kW
	Rated power, output:	0.9 kW
	Speed:	930* RPM
3-phase	Max. power, input:	1.8 kW
	Rated power, output:	1.3 kW
	Speed:	1385* RPM
3-phase	Max. power, input:	3.1 kW
	Rated power, output:	2.3 kW
	Speed:	1375* RPM
WEIGHT:	43 kg	

4410

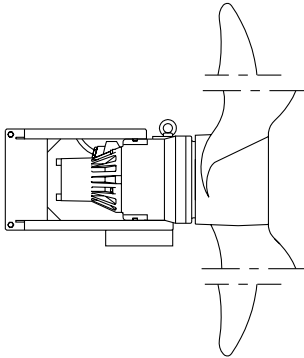

Motor		
3-phase	Max. power, input:	1.3 kW
	Rated power, output:	0.9 kW
	Speed:	930* RPM
3-phase	Max. power, input:	3.1 kW
	Rated power, output:	2.3 kW
	Speed:	1375* RPM
WEIGHT:	250 kg	
MIXER SPEED:	17-40 RPM	

4430

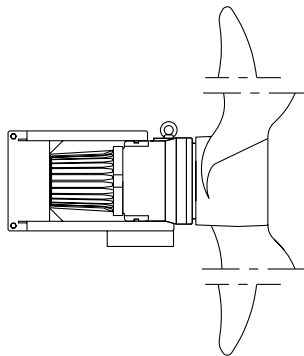

Motor		
3-phase	Max. power, input:	5.0 kW
	Rated power, output:	4.0 kW
	Speed:	1405* RPM
3-phase	Max. power, input:	5.4 kW
	Rated power, output:	4.4 kW
	Speed:	2875* RPM
WEIGHT:	280 kg	
MIXER SPEED:	32-54 RPM	

4610

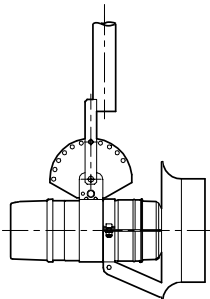

Motor		
3-phase	Max. power, input:	1.0 kW
	Rated power, output:	0.75 kW
	Speed:	1385* RPM
WEIGHT:	16.2 kg	

4620

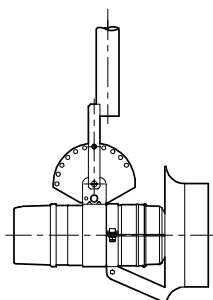

Motor		
3-phase	Max. power, input:	2.2 kW
	Rated power, output:	1.5 kW
	Speed:	1350* RPM
WEIGHT:	17.5 kg	

* 400 V